



Walter  
**Cordbarlag**  
für kontrollierte Späne

■ Made  
■ in  
■ Germany



Inkl. Kressegment-Fräser für bessere Oberflächengüten und kürzere Bearbeitungszeiten  
Incl. Circle Segment End Mills for Better Surface Finish and Shorter Machining Time

**FRANKEN**  
*Turbine*

Fräser für die Impeller- und Schaufelblattbearbeitung  
Milling Cutters for Machining of Impellers and Turbine Blades

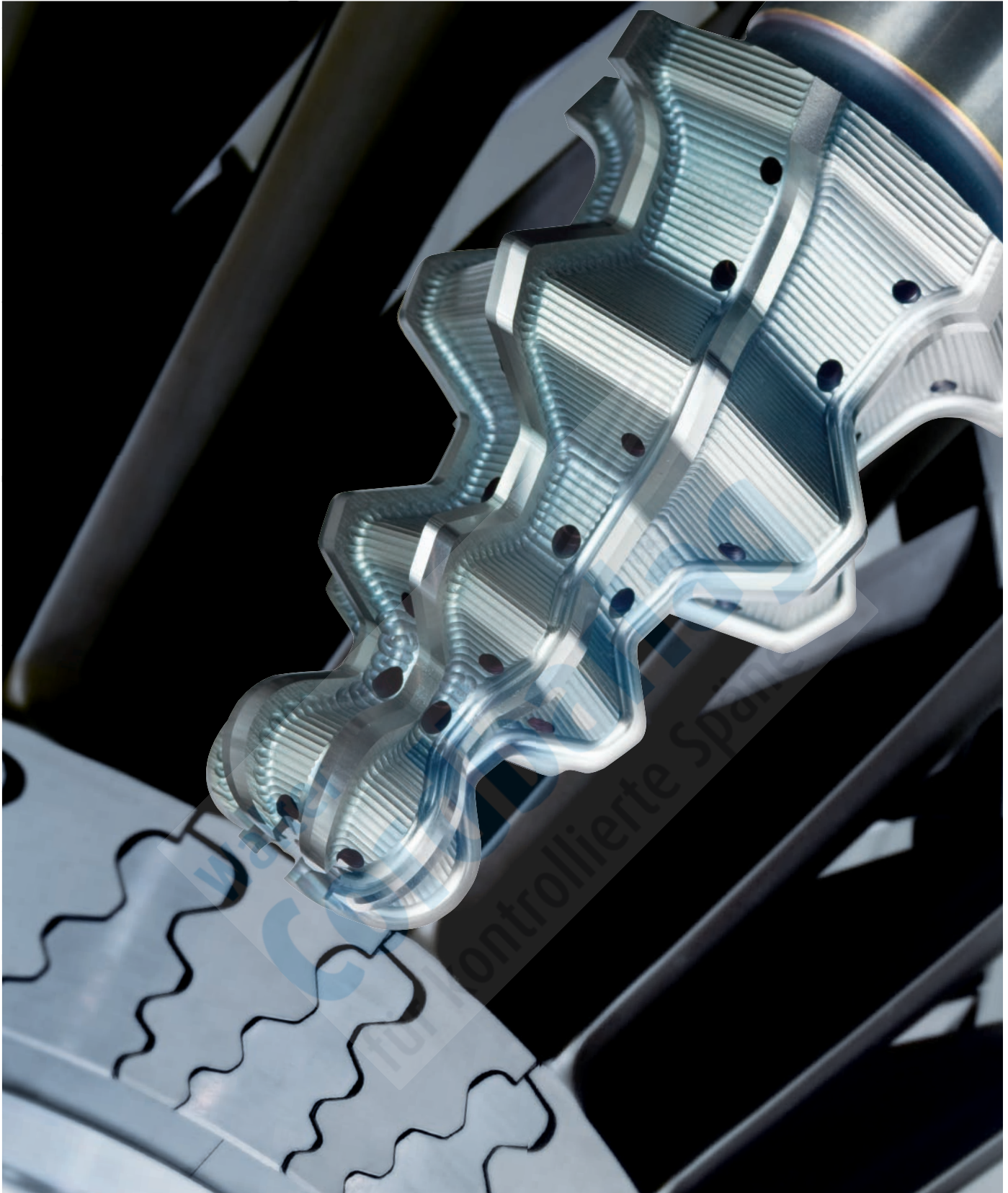

Der **FRANKEN Formfräser „Pagode“** wird zum Schlichten von Schaufelfußnuten und Schaufelfußprofilen eines Turbinenrotors eingesetzt. Die neuartige Spannutegeometrie ermöglicht eine höhere Schneidenanzahl und einen höheren Fräsvorschub gegenüber dem Tannenbaumfräser. Das führt zu einer spürbaren Reduzierung der Bearbeitungszeit bei gleichzeitiger Verdoppelung der Standzeit.

FRANKEN Formfräser „Pagode“ werden entsprechend den Kundenbedürfnissen individuell entwickelt und hergestellt.

The **FRANKEN “Pagode” form milling cutter** is used for finishing the grooves of blade roots and for blade root profiles of turbine rotors. The innovative geometry of the chip flute enables more cutting teeth and an increase of the milling feed compared to a fir tree cutter. The result is a significant reduction of machining time while doubling tool life.

FRANKEN “Pagode” form milling cutters are individually developed and produced according to customer requirements.

FRANKEN, der Pionier bei Kreissegment-Fräsern, vervollständigt sein Fräserprogramm für die Impeller- und Schaufelblattbearbeitung um neue Schrupp- und Schlichtausführungen mit Innenkühlung und Eckenradius „ER“.

Die Schruppausführung ermöglicht es, auch an komplexen Bauteilen und Schaufeln ein konstantes Aufmaß für die nachfolgende Schlichtbearbeitung mit einem weiteren Kreissegment-Fräser herzustellen und damit die Vorschlichtbearbeitung einzusparen. In dieser neuartigen Kombination aus Schruppen mit Vorschlichten und anschließendem Schlichten sind Zeiteinsparungen bei der Fräsbearbeitung von bis zu 50% möglich. Gleichzeitig werden signifikante Verbesserungen der Oberflächen erzielt, was zum Beispiel bei Schaufelblättern aufwändige Nacharbeit durch Entfernung von Bearbeitungsübergängen vermeidet und die Maßhaltigkeit und Formtreue wesentlich verbessert.

Das Fräserprogramm FRANKEN Turbine umfasst Vollhartmetall-Werkzeuge zur Vor- und Fertigbearbeitung von Bauteilen an Turbinen oder anderen komplexen 5-Achs-Bauteilen.

Die beiden neuen, konischen FRANKEN Turbine Torusfräser ergänzen das bisherige Fräserprogramm um weitere Ausführungen mit innerer Kühlschmierstoff-Zufuhr. Diese ermöglicht eine bessere Spanabfuhr und verbessert dadurch die Prozesssicherheit und Standzeiten. Dank einer Schruppverzahnung in Verbindung mit ungleicher Teilung eignen sie sich ideal zum vibrationsarmen Vorfräsen von Impellern, Schaufelblättern oder Integrated Blade Rotors (IBR).

Schneidstoff, Geometrie und Beschichtung aller Fräswerkzeuge sind auf schwer zerspanbare Werkstoffe, wie z.B. Titanlegierungen oder Inconel, ausgerichtet.

Fräswerkzeuge der Produktlinien FRANKEN Turbine und FRANKEN Expert sind auf Anfrage auch in kundenspezifischen Ausführungen erhältlich. Wenden Sie sich hierzu bitte an den für Sie zuständigen Vertriebspartner.

FRANKEN, the pioneer in circle segment end mills, completes the range of milling cutters for machining of impellers and turbine blades with new roughing and finishing versions with internal cooling and corner radius “ER”.

The roughing design makes it possible to produce a constant machining allowance with a circle segment end mill for subsequent finishing even on complex components and turbine blades, thus making the pre-finishing operation redundant. This innovative combination of roughing with pre-finishing and subsequent finishing enables time savings in milling operations of up to 50%. At the same time, significant improvements of the surface quality are achieved, which is the case with turbine blades, for example, where time-consuming rework by removal of machining transitions is no longer necessary and the dimensional precision and form accuracy can be substantially improved.

The FRANKEN Turbine milling cutter range comprises solid carbide tools for the roughing and finishing of components on turbines or other complex 5-axis components.

The two new tapered FRANKEN Turbine torus end mills complement the previous range of milling cutters with additional versions which integrate internal coolant supply. These additions facilitate chip evacuation and thus improve process reliability and tool life. Thanks to a roughing geometry combined with variable spacing they are ideal for low-vibration pre-milling of impellers, turbine blades or integrated blade rotors (IBR).

Cutting material, geometry and coating of all milling tools are geared towards materials which are difficult to machine, such as titanium alloys or Inconel.

Milling tools of the product lines FRANKEN Turbine and FRANKEN Expert are also available in customer-specific versions on request. Please contact your responsible sales partner for details.

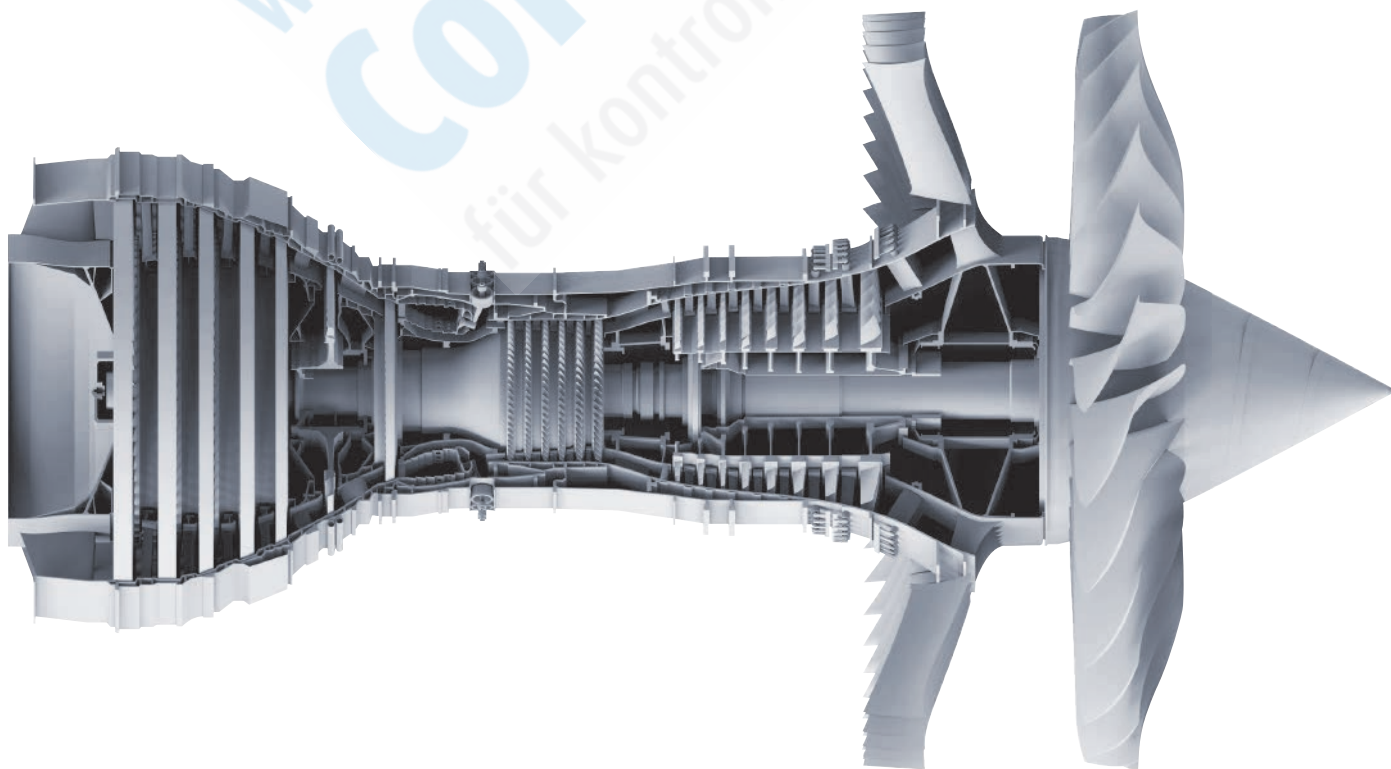

# Wegweiser

**Bitte beachten:**

Die Eignung ist folgendermaßen gekennzeichnet:

- = sehr gut geeignet
- = gut geeignet

Die zugehörigen Schnittwerte sind auf den Seiten 9 bis 51 zu finden.

# Product finder

**Please note:**

The suitability is indicated as follows:

- = very suitable
- = suitable

Please find the cutting conditions on pages 9 up to 51.

| Einsatzgebiete – Material<br>Applications – material                |   | Material-Beispiele<br>Material examples  | Material-Nummern<br>Material numbers   |
|---|---|--|--|
| <b>P</b>  | <b>Stahlwerkstoffe</b><br>Steel materials                         |  |  |
|   | 1.1 Kaltfließpressstähle, Baustähle, Automatenstähle, u.a.        | Cold-extrusion steels, Construction steels, Free-cutting steels, etc.                            | ≤ 600 N/mm <sup>2</sup><br>Cq15 1.1132<br>S235JR (St37-2) 1.0037<br>10SPb20 1.0722   |
|   | 2.1 Baustähle, Einsatzstähle, Stahlguss, u.a.                     | Construction steels, Case-hardened steels, Steel castings, etc.                                  | ≤ 800 N/mm <sup>2</sup><br>E360 (St70-2) 1.0070<br>16MnCr5 1.7131<br>GS-25CrMo4 1.7218   |
|   | 3.1 Einsatzstähle, Vergütungsstähle, Kaltarbeitsstähle, u.a.      | Case-hardened steels, Heat-treatable steels, Cold work steels, etc.                              | ≤ 1000 N/mm <sup>2</sup><br>20MoCr3 1.7320<br>42CrMo4 1.7225<br>102Cr6 1.2067  |
|   | 4.1 Vergütungsstähle, Kaltarbeitsstähle, Nitrierstähle, u.a.      | Heat-treatable steels, Cold work steels, Nitriding steels, etc.                                  | ≤ 1200 N/mm <sup>2</sup><br>50CrMo4 1.7228<br>X45NiCrMo4 1.2767<br>31CrMo12 1.8515   |
| 5.1 Hochlegierte Stähle, Kaltarbeitsstähle, Warmarbeitsstähle, u.a. | High-alloyed steels, Cold work steels, Hot work steels, etc.      | ≤ 1400 N/mm <sup>2</sup><br>X38CrMoV5-3 1.2367<br>X100CrMoV8-1-1 1.2990<br>X40CrMoV5-1 1.2344    |  |
| <b>M</b>  | <b>Nichtrostende Stahlwerkstoffe</b><br>Stainless steel materials |  |  |
|   | 1.1 Ferritisch, martensitisch                                     | Ferritic, martensitic  | ≤ 950 N/mm <sup>2</sup><br>X2CrTi12 1.4512   |
|   | 2.1 Austenitisch  | Austenitic   | ≤ 950 N/mm <sup>2</sup><br>X6CrNiMoTi17-12-2 1.4571  |
|   | 3.1 Austenitisch-ferritisch (Duplex)                              | Austenitic-ferritic (Duplex)   | ≤ 1100 N/mm <sup>2</sup><br>X2CrNiMoN22-5-3 1.4462   |
| 4.1 Austenitisch-ferritisch hitzebeständig (Super Duplex)           | Austenitic-ferritic heat-resistant (Super Duplex)                 | ≤ 1250 N/mm <sup>2</sup><br>X2CrNiMoN25-7-4 1.4410   |  |
| <b>K</b>  | <b>Gusswerkstoffe</b><br>Cast materials                           |  |  |
|   | 1.1 Gusseisen mit Lamellengrafit (GJL)                            | Cast iron with lamellar graphite (GJL)   | 100-250 N/mm <sup>2</sup><br>EN-GJL-200 (GG20) EN-JL-1030  |
|   | 2.1 Gusseisen mit Kugelgrafit (GJS)                               | Cast iron with nodular graphite (GJS)  | 250-450 N/mm <sup>2</sup><br>EN-GJL-300 (GG30) EN-JL-1050  |
|   | 2.2 Gusseisen mit Kugelgrafit (GJS)                               | Cast iron with nodular graphite (GJS)  | 350-500 N/mm <sup>2</sup><br>EN-GJS-400-15 (GGG40) EN-JS-1030  |
|   | 3.1 Gusseisen mit Vermiculargrafit (GJV)                          | Cast iron with vermicular graphite (GJV)   | 500-900 N/mm <sup>2</sup><br>EN-GJS-700-2 (GGG70) EN-JS-1070   |
|   | 3.2 Gusseisen mit Vermiculargrafit (GJV)                          | Cast iron with vermicular graphite (GJV)   | 300-400 N/mm <sup>2</sup><br>GJV 300   |
|   | 4.1 Temperguss (GTMW, GTMB)                                       | Malleable cast iron (GTMW, GTMB)   | 400-500 N/mm <sup>2</sup><br>GJV 450   |
| 4.2 Temperguss (GTMW, GTMB)   | Malleable cast iron (GTMW, GTMB)                                  | 250-500 N/mm <sup>2</sup><br>EN-GJMW-350-4 (GTW-35) EN-GJMB-450-6 (GTS-45) EN-JM-1010 EN-JM-1140 |  |
| <b>N</b>  | <b>Nichteisenwerkstoffe</b><br>Non-ferrous materials              |  |  |
|   | 1.1 Aluminium-Legierungen   | Aluminium alloys   | ≤ 200 N/mm <sup>2</sup><br>EN AW-AlMn1 EN AW-3103  |
|   | 1.2 Aluminium-Knetlegierungen                                     | Wrought aluminium alloys   | ≤ 350 N/mm <sup>2</sup><br>EN AW-AlMgSi EN AW-6060   |
|   | 1.3 Aluminium-Knetlegierungen                                     | Wrought aluminium alloys   | ≤ 550 N/mm <sup>2</sup><br>EN AW-AlZn5Mg3Cu EN AW-7022   |
|   | 1.4 Aluminium-Knetlegierungen                                     | Wrought aluminium alloys   | Si ≤ 7%<br>EN AC-AlMg5 EN AC-51300   |
|   | 1.5 Aluminium-Gusslegierungen                                     | Aluminium cast alloys  | 7% < Si ≤ 12%<br>EN AC-AISi9Cu3 EN AC-46500  |
|   | 1.6 Aluminium-Gusslegierungen                                     | Aluminium cast alloys  | 12% < Si ≤ 17%<br>GD-AISi17Cu4FeMg   |
|   | 2.1 Reinkupfer, niedriglegiertes Kupfer                           | Copper alloys  | ≤ 400 N/mm <sup>2</sup><br>Pure copper, low-alloyed copper E-Cu 57   |
|   | 2.2 Kupfer-Zink-Legierungen (Messing, langspanend)                | Copper-zinc alloys (brass, long-chipping)  | ≤ 550 N/mm <sup>2</sup><br>CuZn37 (Ms63) EN CW 508 L   |
|   | 2.3 Kupfer-Zink-Legierungen (Messing, kurzspanend)                | Copper-zinc alloys (brass, short-chipping)   | ≤ 550 N/mm <sup>2</sup><br>CuZn36Pb3 (Ms58) EN CW 603 N  |
|   | 2.4 Kupfer-Aluminium-Legierungen (Alubronze, langspanend)         | Copper-aluminium alloys (alu bronze, long-chipping)  | ≤ 800 N/mm <sup>2</sup><br>CuAl10Ni5Fe4 EN CW 307 G  |
|   | 2.5 Kupfer-Zinn-Legierungen (Zinnbronze, langspanend)             | Copper-tin alloys (tin bronze, long-chipping)  | ≤ 700 N/mm <sup>2</sup><br>CuSn8P EN CW 459 K  |
|   | 2.6 Kupfer-Zinn-Legierungen (Zinnbronze, kurzspanend)             | Copper-tin alloys (tin bronze, short-chipping)   | ≤ 400 N/mm <sup>2</sup><br>CuSn7 ZnPb (Rg7) 2.1090   |
|   | 2.7 Kupfer-Sonderlegierungen                                      | Special copper alloys  | ≤ 600 N/mm <sup>2</sup><br>(AMPCO® 8)  |
|   | 2.8 Kupfer-Sonderlegierungen                                      | Special copper alloys  | ≤ 1400 N/mm <sup>2</sup><br>(AMPCO® 45)  |
|   | 3.1 Magnesium-Knetlegierungen                                     | Magnesium wrought alloys   | ≤ 500 N/mm <sup>2</sup><br>MgAl6Zn 3.5612  |
| 3.2 Magnesium-Gusslegierungen                                       | Magnesium cast alloys   | ≤ 500 N/mm <sup>2</sup><br>EN-MCMgAl9Zn1 EN-MC21120  |  |
| <b>S</b>  | <b>Kunststoffe</b><br>Synthetics                                  |  |  |
|   | 4.1 Duroplaste (kurzspanend)                                      | Duroplastics (short-chipping)  | Bakelit, Pertinax  |
|   | 4.2 Thermoplaste (langspanend)                                    | Thermoplastics (long-chipping)   | PMMA, POM, PVC   |
|   | 4.3 Faserverstärkte Kunststoffe (Faseranteil ≤ 30%)               | Fibre-reinforced synthetics (fibre content ≤ 30%)  | GFK, CFK, AFK  |
|   | 4.4 Faserverstärkte Kunststoffe (Faseranteil > 30%)               | Fibre-reinforced synthetics (fibre content > 30%)  | GFK, CFK, AFK  |
|   | 5.1 Besondere Werkstoffe  | Special materials  |  |
|   | 5.2 Wolfram-Kupfer-Legierungen                                    | Tungsten-copper alloys   | C 8000   |
|   | 5.3 Verbundwerkstoffe   | Composite materials  | W-Cu 80/20<br>HyLite, Alucobond  |
|   | <b>Spezialwerkstoffe</b><br>Special materials                     |  |  |
|   | 1.1 Titan-Legierungen   | Titanium alloys  | ≤ 450 N/mm <sup>2</sup><br>Ti1 3.7025  |
| 1.2 Titan-Legierungen   | Titanium alloys   | ≤ 900 N/mm <sup>2</sup><br>TiAl6V4 3.7165  |  |
| 1.3 Titan-Legierungen   | Titanium alloys   | ≤ 1250 N/mm <sup>2</sup><br>TiAl4Mo4Sn2 3.7185   |  |
| 2.1 Nickel-, Kobalt- und Eisen-Legierungen                          | Nickel alloys, cobalt alloys and iron alloys                      |  |  |
| 2.2 Reinnickel  | Pure nickel   | ≤ 600 N/mm <sup>2</sup><br>Ni 99.6 2.4060  |  |
| 2.3 Nickel-Basis-Legierungen  | Nickel-base alloys  | ≤ 1000 N/mm <sup>2</sup><br>Monel 400 2.4360   |  |
| 2.4 Nickel-Basis-Legierungen  | Nickel-base alloys  | ≤ 1600 N/mm <sup>2</sup><br>Inconel 718 2.4668   |  |
| 2.5 Kobalt-Basis-Legierungen  | Cobalt-base alloys  | ≤ 1000 N/mm <sup>2</sup><br>Udimet 605   |  |
| 2.6 Eisen-Basis-Legierungen   | Iron-base alloys  | ≤ 1600 N/mm <sup>2</sup><br>Haynes 25 2.4964   |  |
| <b>H</b>  | <b>Harte Werkstoffe</b><br>Hard materials                         |  |  |
|   | 1.1 Hochfeste Stähle, gehärtete Stähle, Hartguss                  | High strength steels, hardened steels, hard castings   | ≤ 1500 N/mm <sup>2</sup><br>44 - 50 HRC Weldox 1100<br>50 - 55 HRC Hardox 550<br>55 - 60 HRC Armax 600T<br>60 - 63 HRC Ferro-Titanit<br>63 - 66 HRC HSSE |
|   | 1.2 Hochfeste Stähle, gehärtete Stähle, Hartguss                  | High strength steels, hardened steels, hard castings   |  |
|   | 1.3 Hochfeste Stähle, gehärtete Stähle, Hartguss                  | High strength steels, hardened steels, hard castings   |  |
|   | 1.4 Hochfeste Stähle, gehärtete Stähle, Hartguss                  | High strength steels, hardened steels, hard castings   |  |
|   | 1.5 Hochfeste Stähle, gehärtete Stähle, Hartguss                  | High strength steels, hardened steels, hard castings   |  |

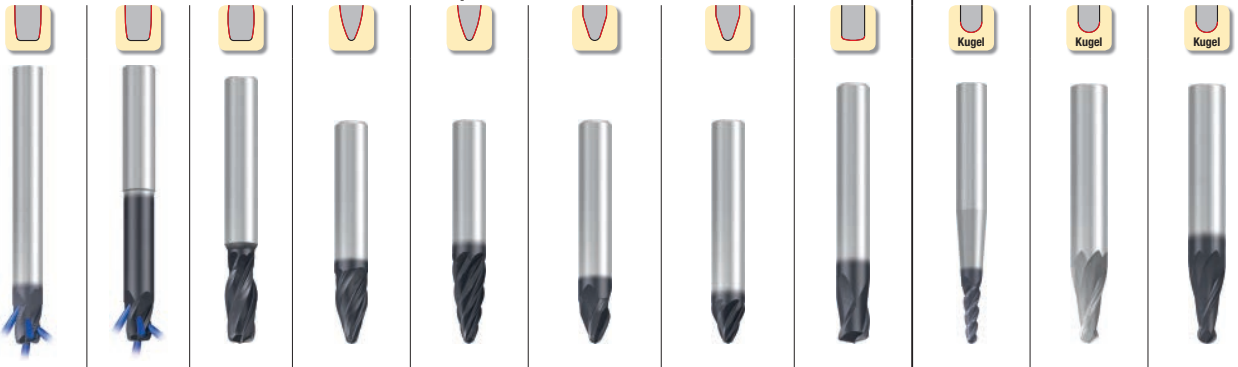

| Allround    |             |                        |                             |              |   |   |                            | Allround                            |   |   | Z (Flutes) |
|-------------|-------------|------------------------|-----------------------------|--------------|---|---|----------------------------|-------------------------------------|---|---|------------|
| NR          | N           |                        |                             |              |   |   |                            | NR                                  | NF  |   |            |
| fein · fine | N           |                        |                             |              |   |   |                            | fein · fine                         | fein · fine                               |   |            |
| ø 8 - 16 mm | ø 8 - 16 mm | r <sub>2</sub> = 50 mm | r <sub>2</sub> = 75 - 95 mm | ø 10 - 16 mm | α <sub>2</sub> = 12,5 - 70°<br>r <sub>2</sub> = 200 - 1500 mm | α <sub>2</sub> = 12,5 - 70°<br>r <sub>2</sub> = 200 - 1000 mm | r <sub>2</sub> = 6 - 25 mm | α <sub>2</sub> = 4°<br>r = 2 - 4 mm | α <sub>2</sub> = 3 - 8°<br>r = 0,5 - 2 mm | α <sub>2</sub> = 3 - 8°<br>r = 0,5 - 2 mm |            |
| 4           | 4           | 4                      | 3 - 4                       | 6            | 2 - 3   | 4 - 6   | 3                          | 3                                   | 2   | 2   |            |
| 3552LZ      | 3554LZ      | 3542L                  | 3538L                       | 3539L        | 3540L   | 3541L   | 3544L                      | 3546L                               | 3446 / 3447                               | 3446L                                     |            |
| -           | -           | -                      | -                           | -            | -   | -   | -                          | -                                   | -   | -   |            |
| 8           | 10          | 12                     | 14                          | 16           | 18  | 20  | 22                         | 24                                  | 26  | 26  |            |
| 9           | 11          | 13                     | 15                          | 17           | 19  | 21  | 23                         | 25                                  | 27  | 27  |            |

|   |   |   |   |   |   |   |   |   |   |   |     |
|---|---|---|---|---|---|---|---|---|---|---|-----|
| ■ | ■ | ■ | ■ | ■ | ■ | ■ | ■ | ■ | ■ | ■ | 1.1 |
| ■ | ■ | ■ | ■ | ■ | ■ | ■ | ■ | ■ | ■ | ■ | 2.1 |
| ■ | ■ | ■ | ■ | ■ | ■ | ■ | ■ | ■ | ■ | ■ | 3.1 |
| ■ | ■ | ■ | ■ | ■ | ■ | ■ | ■ | ■ | ■ | □ | 4.1 |
| ■ | ■ | ■ | ■ | ■ | ■ | ■ | ■ | ■ | ■ | □ | 5.1 |
| ■ | ■ | ■ | ■ | ■ | ■ | ■ | ■ | ■ | ■ | ■ | 1.1 |
| ■ | ■ | ■ | ■ | ■ | ■ | ■ | ■ | ■ | ■ | ■ | 2.1 |
| ■ | ■ | ■ | ■ | ■ | ■ | ■ | ■ | ■ | ■ | ■ | 3.1 |
| ■ | ■ | ■ | ■ | ■ | ■ | ■ | ■ | ■ | ■ | ■ | 4.1 |
| ■ | ■ | ■ | ■ | ■ | ■ | ■ | ■ | ■ | ■ | ■ | 1.1 |
| ■ | ■ | ■ | ■ | ■ | ■ | ■ | ■ | ■ | ■ | ■ | 1.2 |
| ■ | ■ | ■ | ■ | ■ | ■ | ■ | ■ | ■ | ■ | ■ | 2.1 |
| ■ | ■ | ■ | ■ | ■ | ■ | ■ | ■ | ■ | ■ | ■ | 2.2 |
| ■ | ■ | ■ | ■ | ■ | ■ | ■ | ■ | ■ | ■ | ■ | 2.3 |
| ■ | ■ | ■ | ■ | ■ | ■ | ■ | ■ | ■ | ■ | ■ | 2.4 |
| ■ | ■ | ■ | ■ | ■ | ■ | ■ | ■ | ■ | ■ | ■ | 2.5 |
| ■ | ■ | ■ | ■ | ■ | ■ | ■ | ■ | ■ | ■ | ■ | 2.6 |
| ■ | ■ | ■ | ■ | ■ | ■ | ■ | ■ | ■ | ■ | ■ | 2.7 |
| ■ | ■ | ■ | ■ | ■ | ■ | ■ | ■ | ■ | ■ | ■ | 2.8 |
| ■ | ■ | ■ | ■ | ■ | ■ | ■ | ■ | ■ | ■ | ■ | 3.1 |
| ■ | ■ | ■ | ■ | ■ | ■ | ■ | ■ | ■ | ■ | ■ | 3.2 |
| ■ | ■ | ■ | ■ | ■ | ■ | ■ | ■ | ■ | ■ | ■ | 4.1 |
| ■ | ■ | ■ | ■ | ■ | ■ | ■ | ■ | ■ | ■ | ■ | 4.2 |
| ■ | ■ | ■ | ■ | ■ | ■ | ■ | ■ | ■ | ■ | ■ | 4.3 |
| ■ | ■ | ■ | ■ | ■ | ■ | ■ | ■ | ■ | ■ | ■ | 4.4 |
| ■ | ■ | ■ | ■ | ■ | ■ | ■ | ■ | ■ | ■ | ■ | 5.1 |
| ■ | ■ | ■ | ■ | ■ | ■ | ■ | ■ | ■ | ■ | ■ | 5.2 |
| ■ | ■ | ■ | ■ | ■ | ■ | ■ | ■ | ■ | ■ | ■ | 5.3 |
| ■ | ■ | ■ | ■ | ■ | ■ | ■ | ■ | ■ | ■ | ■ | 1.1 |
| ■ | ■ | ■ | ■ | ■ | ■ | ■ | ■ | ■ | ■ | ■ | 1.2 |
| ■ | ■ | ■ | ■ | ■ | ■ | ■ | ■ | ■ | ■ | ■ | 1.3 |
| ■ | ■ | ■ | ■ | ■ | ■ | ■ | ■ | ■ | ■ | ■ | 2.1 |
| ■ | ■ | ■ | ■ | ■ | ■ | ■ | ■ | ■ | ■ | ■ | 2.2 |
| ■ | ■ | ■ | ■ | ■ | ■ | ■ | ■ | ■ | ■ | ■ | 2.3 |
| ■ | ■ | ■ | ■ | ■ | ■ | ■ | ■ | ■ | ■ | ■ | 2.4 |
| ■ | ■ | ■ | ■ | ■ | ■ | ■ | ■ | ■ | ■ | ■ | 2.5 |
| ■ | ■ | ■ | ■ | ■ | ■ | ■ | ■ | ■ | ■ | ■ | 2.6 |
| ■ | ■ | ■ | ■ | ■ | ■ | ■ | ■ | ■ | ■ | ■ | 1.1 |
| ■ | ■ | ■ | ■ | ■ | ■ | ■ | ■ | ■ | ■ | ■ | 1.2 |
| ■ | ■ | ■ | ■ | ■ | ■ | ■ | ■ | ■ | ■ | ■ | 1.3 |
| ■ | ■ | ■ | ■ | ■ | ■ | ■ | ■ | ■ | ■ | ■ | 1.4 |
| ■ | ■ | ■ | ■ | ■ | ■ | ■ | ■ | ■ | ■ | ■ | 1.5 |

■ = sehr gut geeignet · very suitable  
□ = gut geeignet · suitable

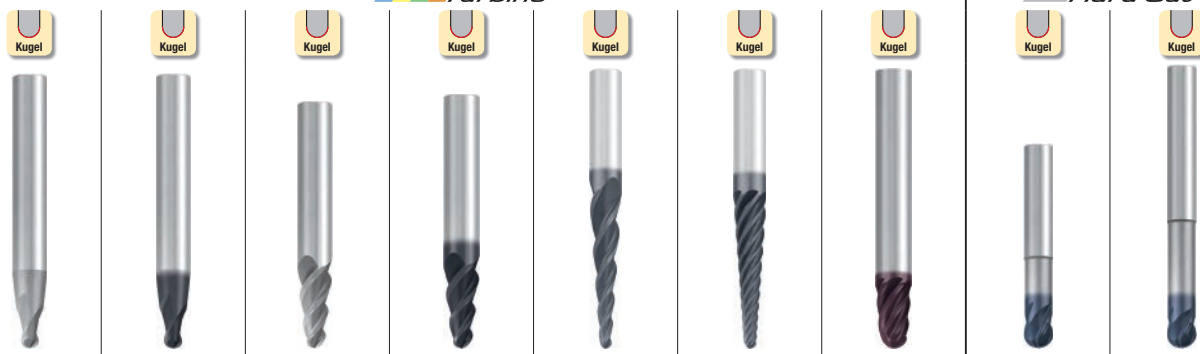

Allround

Hard materials

**N**

**H**

|              | $\alpha/2 = 3 - 8^\circ$<br>$r = 1,5 - 3 \text{ mm}$ | $\alpha/2 = 3 - 8^\circ$<br>$r = 1,5 - 3 \text{ mm}$ | $\alpha/2 = 3 - 17,5^\circ$<br>$r = 0,5 - 3 \text{ mm}$ | $\alpha/2 = 3 - 17,5^\circ$<br>$r = 0,5 - 3 \text{ mm}$ | $\alpha/2 = 4^\circ$<br>$r = 2 - 4 \text{ mm}$ | $\alpha/2 = 4^\circ$<br>$r = 2 - 4 \text{ mm}$ | $\alpha/2 = 4^\circ$<br>$r = 3 - 8 \text{ mm}$ | $\emptyset 3 - 12 \text{ mm}$ | $\emptyset 6 - 12 \text{ mm}$ |
|--------------|--|--|---|---|--|--|--|-------------------------------|-------------------------------|
| Z (Flutes)   | 2  | 2  | 2   | 2   | 3  | 3/6  | 3/6  | 4                             | 4                             |
|              | 3442 / 3443  | 3442L  | 3440 / 3441   | 3440L   | 3550L  | 3548L  | 2679A  | 2834A                         | 2842A                         |
| Seite · Page | 28   | 28   | 30  | 30  | 32   | 34   | 36   | 38                            | 40                            |
| $v_c / f_z$  | 29   | 29   | 31  | 31  | 33   | 35   | 37   | 39                            | 41                            |

|          |     |   |   |   |   |   |   |   |   |
|----------|-----|---|---|---|---|---|---|---|---|
| <b>P</b> | 1.1 | ■ | ■ | ■ | ■ | ■ | ■ | □ | □ |
|          | 2.1 | ■ | ■ | ■ | ■ | ■ | ■ | □ | □ |
|          | 3.1 | ■ | ■ | ■ | ■ | ■ | ■ | ■ | ■ |
|          | 4.1 | □ | □ | □ | □ | ■ | ■ | ■ | ■ |
|          | 5.1 | □ | □ | □ | □ | ■ | ■ | ■ | ■ |
| <b>M</b> | 1.1 | ■ | ■ | ■ | ■ | ■ | ■ | ■ | ■ |
|          | 2.1 | ■ | ■ | ■ | ■ | ■ | ■ | ■ | ■ |
|          | 3.1 | ■ | ■ | ■ | ■ | ■ | ■ | ■ | ■ |
|          | 4.1 | ■ | ■ | ■ | ■ | ■ | ■ | ■ | ■ |
| <b>K</b> | 1.1 | ■ | ■ | ■ | ■ | ■ | ■ | ■ | ■ |
|          | 1.2 | ■ | ■ | ■ | ■ | ■ | ■ | ■ | ■ |
|          | 2.1 | ■ | ■ | ■ | ■ | ■ | ■ | ■ | ■ |
|          | 2.2 | ■ | ■ | ■ | ■ | ■ | ■ | ■ | ■ |
|          | 3.1 | □ | □ | □ | □ | ■ | ■ | ■ | ■ |
|          | 3.2 | □ | □ | □ | □ | ■ | ■ | ■ | ■ |
|          | 4.1 | □ | □ | □ | □ | ■ | ■ | ■ | ■ |
| 4.2      | □   | □ | □ | □ | ■ | ■ | ■ | ■ |   |
| <b>N</b> | 1.1 | ■ | ■ | ■ | ■ | ■ | ■ | ■ | ■ |
|          | 1.2 | ■ | ■ | ■ | ■ | ■ | ■ | ■ | ■ |
|          | 1.3 | ■ | ■ | ■ | ■ | ■ | ■ | ■ | ■ |
|          | 1.4 | ■ | ■ | ■ | ■ | ■ | ■ | ■ | ■ |
|          | 1.5 | □ | □ | □ | □ | ■ | ■ | ■ | ■ |
|          | 1.6 | □ | □ | □ | □ | ■ | ■ | ■ | ■ |
|          | 2.1 | ■ | ■ | ■ | ■ | ■ | ■ | ■ | ■ |
|          | 2.2 | ■ | ■ | ■ | ■ | ■ | ■ | □ | □ |
|          | 2.3 | ■ | ■ | ■ | ■ | ■ | ■ | □ | □ |
|          | 2.4 | ■ | ■ | ■ | ■ | ■ | ■ | □ | □ |
|          | 2.5 | ■ | ■ | ■ | ■ | ■ | ■ | □ | □ |
|          | 2.6 | ■ | ■ | ■ | ■ | ■ | ■ | ■ | ■ |
|          | 2.7 | □ | □ | □ | □ | ■ | ■ | ■ | ■ |
|          | 2.8 | □ | □ | □ | □ | ■ | ■ | ■ | ■ |
|          | 3.1 | ■ | ■ | ■ | ■ | ■ | ■ | ■ | ■ |
| 3.2      | ■   | ■ | ■ | ■ | ■ | ■ | ■ | ■ |   |
| 4.1      | ■   | ■ | ■ | ■ | ■ | ■ | ■ | ■ |   |
| 4.2      | ■   | ■ | ■ | ■ | ■ | ■ | ■ | ■ |   |
| 4.3      | ■   | ■ | ■ | ■ | ■ | ■ | ■ | ■ |   |
| 4.4      | ■   | ■ | ■ | ■ | ■ | ■ | ■ | ■ |   |
| 5.1      | ■   | ■ | ■ | ■ | ■ | ■ | ■ | ■ |   |
| 5.2      | ■   | ■ | ■ | ■ | ■ | ■ | ■ | ■ |   |
| 5.3      | ■   | ■ | ■ | ■ | ■ | ■ | ■ | ■ |   |
| <b>S</b> | 1.1 | ■ | ■ | ■ | ■ | ■ | ■ | ■ | ■ |
|          | 1.2 | ■ | ■ | ■ | ■ | ■ | ■ | ■ | ■ |
|          | 1.3 | □ | □ | □ | □ | ■ | ■ | ■ | ■ |
|          | 2.1 | ■ | ■ | ■ | ■ | ■ | ■ | ■ | ■ |
|          | 2.2 | ■ | ■ | ■ | ■ | ■ | ■ | ■ | ■ |
|          | 2.3 | □ | □ | □ | □ | ■ | ■ | ■ | ■ |
| 2.4      | □   | □ | □ | □ | ■ | ■ | ■ | ■ |   |
| 2.5      | □   | □ | □ | □ | ■ | ■ | ■ | ■ |   |
| 2.6      | □   | □ | □ | □ | ■ | ■ | ■ | ■ |   |
| <b>H</b> | 1.1 | ■ | ■ | ■ | ■ | ■ | ■ | ■ | ■ |
|          | 1.2 | ■ | ■ | ■ | ■ | ■ | ■ | ■ | ■ |
|          | 1.3 | ■ | ■ | ■ | ■ | ■ | ■ | ■ | ■ |
|          | 1.4 | ■ | ■ | ■ | ■ | ■ | ■ | ■ | ■ |
|          | 1.5 | ■ | ■ | ■ | ■ | ■ | ■ | ■ | ■ |



Allround

**N**

**NR**

fein · fine

**N**

ø4 - 10 mm

$\alpha/2 = 3^\circ$   
ø6,5 - 8,5 mm

$\alpha/2 = 3^\circ$   
ø5 - 6 mm

$\alpha/2 = 3 - 8^\circ$   
ød<sub>1</sub> = 3 - 5 mm

$\alpha/2 = 3 - 8^\circ$   
ød<sub>1</sub> = 3 - 5 mm

$\alpha/2 = 8^\circ$   
ød<sub>1</sub> = 8 - 11 mm

$\alpha/2 = 8^\circ$   
ød<sub>1</sub> = 9 - 19 mm

ød<sub>1</sub> = 8 - 16 mm

4

4

3

2

2

7 - 9

5 - 13

5 - 9

2564L

-

-

3444 / 3445

3444L

2677AZ

2678AZ

2676AZ

-

3534LZ

3532LZ

-

-

-

-

-

42

44

44

46

46

48

48

50

43

45

45

47

47

49

49

51

Z (Flutes)



Seite · Page

$v_c / f_z$

|  |   |   |   |  |   |   |   |   |     |   |
|--|---|---|---|--|---|---|---|---|-----|---|
|  | ■ | ■ | ■ |  | ■ | ■ | ■ | ■ | 1.1 | P |
|  | ■ | ■ | ■ |  | ■ | ■ | ■ | ■ | 2.1 |   |
|  | ■ | ■ | ■ |  | ■ | ■ | ■ | ■ | 3.1 |   |
|  | ■ | ■ | ■ |  | □ | ■ | ■ | ■ | 4.1 |   |
|  | ■ | ■ | ■ |  | □ | ■ | ■ | ■ | 5.1 |   |
|  | ■ | ■ | ■ |  | ■ | ■ | ■ | ■ | 1.1 | M |
|  | ■ | ■ | ■ |  | ■ | ■ | ■ | ■ | 2.1 |   |
|  | ■ | ■ | ■ |  | ■ | ■ | ■ | ■ | 3.1 |   |
|  | ■ | ■ | ■ |  | ■ | ■ | ■ | ■ | 4.1 |   |
|  | □ | □ | □ |  | ■ | ■ | ■ | ■ | 1.1 | K |
|  | □ | □ | □ |  | ■ | ■ | ■ | ■ | 1.2 |   |
|  | □ | □ | □ |  | ■ | ■ | ■ | ■ | 2.1 |   |
|  | □ | □ | □ |  | ■ | ■ | ■ | ■ | 2.2 |   |
|  | □ | □ | □ |  | □ | ■ | ■ | ■ | 3.1 |   |
|  | □ | □ | □ |  | □ | ■ | ■ | ■ | 3.2 |   |
|  | □ | □ | □ |  | □ | ■ | ■ | ■ | 4.1 |   |
|  | □ | □ | □ |  | □ | ■ | ■ | ■ | 4.2 |   |
|  |   | ■ | ■ |  | ■ | ■ | ■ | ■ | 1.1 | N |
|  |   | ■ | ■ |  | ■ | ■ | ■ | ■ | 1.2 |   |
|  |   | ■ | ■ |  | ■ | ■ | ■ | ■ | 1.3 |   |
|  |   | ■ | ■ |  | ■ | ■ | ■ | ■ | 1.4 |   |
|  |   |   |   |  | □ | ■ | ■ | ■ | 1.5 |   |
|  |   |   |   |  |   | ■ | ■ | ■ | 1.6 |   |
|  | ■ |   |   |  | ■ | ■ | ■ | ■ | 2.1 | N |
|  | ■ |   |   |  | ■ | ■ | ■ | ■ | 2.2 |   |
|  | ■ |   |   |  | ■ | ■ | ■ | ■ | 2.3 |   |
|  | ■ |   |   |  | ■ | ■ | ■ | ■ | 2.4 |   |
|  | ■ |   |   |  | ■ | ■ | ■ | ■ | 2.5 |   |
|  | ■ |   |   |  | □ | ■ | ■ | ■ | 2.6 |   |
|  | ■ |   |   |  | □ | ■ | ■ | ■ | 2.7 |   |
|  | ■ |   |   |  | □ | ■ | ■ | ■ | 2.8 |   |
|  |   |   |   |  | ■ | ■ | ■ | ■ | 3.1 | N |
|  |   |   |   |  | ■ | ■ | ■ | ■ | 3.2 |   |
|  |   |   |   |  |   | ■ | ■ | ■ | 4.1 |   |
|  |   |   |   |  | ■ | ■ | ■ | ■ | 4.2 |   |
|  |   |   |   |  | ■ | ■ | ■ | ■ | 4.3 |   |
|  |   |   |   |  | ■ | ■ | ■ | ■ | 4.4 |   |
|  |   |   |   |  |   | ■ | ■ | ■ | 5.1 |   |
|  |   |   |   |  |   | ■ | ■ | ■ | 5.2 |   |
|  |   |   |   |  |   | ■ | ■ | ■ | 5.3 |   |
|  |   |   |   |  |   |   | ■ | ■ |     |   |
|  | ■ | ■ | ■ |  | ■ | ■ | ■ | ■ | 1.1 | S |
|  | ■ | ■ | ■ |  | ■ | ■ | ■ | ■ | 1.2 |   |
|  | ■ | ■ | ■ |  | □ | ■ | ■ | ■ | 1.3 |   |
|  | ■ | ■ | ■ |  | ■ | ■ | ■ | ■ | 2.1 | S |
|  | ■ | ■ | ■ |  | ■ | ■ | ■ | ■ | 2.2 |   |
|  | ■ | ■ | ■ |  | □ | ■ | ■ | ■ | 2.3 |   |
|  | ■ | ■ | ■ |  | □ | ■ | ■ | ■ | 2.4 |   |
|  | ■ | ■ | ■ |  | □ | ■ | ■ | ■ | 2.5 |   |
|  | ■ | ■ | ■ |  | □ | ■ | ■ | ■ | 2.6 |   |
|  | □ | □ | □ |  |   |   |   |   | 1.1 | H |
|  | □ | □ | □ |  |   |   |   |   | 1.2 |   |
|  | □ | □ | □ |  |   |   |   |   | 1.3 |   |
|  |   |   |   |  |   |   |   |   | 1.4 |   |
|  |   |   |   |  |   |   |   |   | 1.5 |   |

- Hochleistungswerkzeug
- Mit 4 Schneiden
- Ungleiche Teilung
- Vibrationsarme Bearbeitung
- Hocheffiziente Schruppbearbeitung

- High performance tool
- With 4 flutes
- Variable spacing
- Low-vibration machining
- Highly efficient roughing

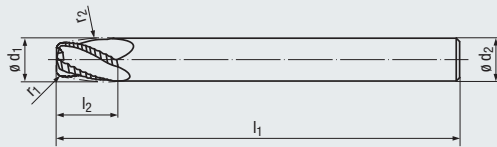
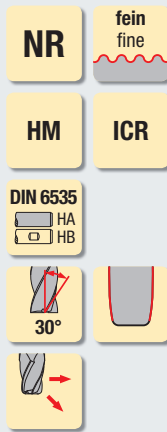

Tropfenform – ER  
Oval Form – ER



Allround

**Beschichtung · Coating**

**Einsatzgebiete – Material (siehe Seite 4)**

- Speziell für hochfeste Werkstoffe geeignet
- Auch für Nickel-Basis-Legierungen einsetzbar
- Für die Zerspanung von Titan-Legierungen geeignet
- Einsatz in allen Turbinenwerkstoffen möglich
- Optimierte zur Vorbearbeitung von Impellern und Integrated Bladed Rotors (IBR) aus Aluminium, Titan und Inconel

**Applications – material (see page 4)**

- Especially suitable for high-strength materials
- Also suitable in nickel-base alloys
- For the machining of titanium alloys
- Suitable in all turbine materials
- Optimised for pre-finishing Impellers and Integrated Bladed Rotors (IBR) made from aluminium, titanium and Inconel

**ALCR**

- P** 1.1-5.1
- M** 1.1-4.1
- N** 1.1-1.3
- S** 1.1-1.3
- S** 2.2-2.6

**Bestell-Code · Order code**

**3552LZ**

| d <sub>1</sub> | r <sub>1</sub> | r <sub>2</sub> | l <sub>2</sub> | l <sub>1</sub> | ∅ d <sub>2</sub><br>h6 | Z<br>(Flutes) | Dimens.-<br>Code |   |  |  |
|----------------|----------------|----------------|----------------|----------------|------------------------|---------------|------------------|---|--|--|
| 8              | 1              | 40             | 12             | 80             | 8                      | 4             | .08040A          | ● |  |  |
| 10             | 1,5            | 45             | 12             | 95             | 10                     | 4             | .10045A          | ● |  |  |
| 12             | 2              | 50             | 14             | 100            | 12                     | 4             | .12050A          | ● |  |  |
| 16             | 2              | 60             | 18             | 128            | 16                     | 4             | .16060A          | ● |  |  |



**Wirtschaftlichkeitsberechnung für Kreissegment-Fräser**

Economical calculation for circle segment end mills

[www.frankenexpert.com](http://www.frankenexpert.com)



**Kreissegment-Fräser mit Tropfenform – ER**  
Circle segment end mills with oval form – ER

NR

Gültig für · Valid for  
3552LZ

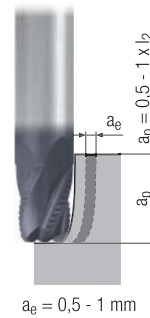
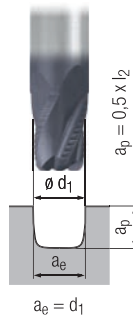

|          | $V_c$<br>[m/min] | $f_z$<br>[mm]      | $V_c$<br>[m/min]   | $f_z$<br>[mm]      |                    |  |   |   |   |
|----------|------------------|--------------------|--------------------|--------------------|--------------------|--|---|---|---|
| <b>P</b> | 1.1              | 100                | $0,004 \times d_1$ | 140                | $0,005 \times d_1$ |  | ■ | □ | ■ |
|          | 2.1              | 90                 | $0,004 \times d_1$ | 130                | $0,004 \times d_1$ |  | ■ | □ | ■ |
|          | 3.1              | 90                 | $0,003 \times d_1$ | 120                | $0,004 \times d_1$ |  | ■ | □ | ■ |
|          | 4.1              | 80                 | $0,002 \times d_1$ | 110                | $0,003 \times d_1$ |  | ■ | □ | ■ |
|          | 5.1              | 70                 | $0,002 \times d_1$ | 100                | $0,003 \times d_1$ |  | ■ | □ | ■ |
| <b>M</b> | 1.1              | 80                 | $0,004 \times d_1$ | 100                | $0,005 \times d_1$ |  |   |   | ■ |
|          | 2.1              | 70                 | $0,003 \times d_1$ | 80                 | $0,004 \times d_1$ |  |   |   | ■ |
|          | 3.1              | 60                 | $0,002 \times d_1$ | 70                 | $0,003 \times d_1$ |  |   |   | ■ |
|          | 4.1              | 60                 | $0,002 \times d_1$ | 70                 | $0,003 \times d_1$ |  |   |   | ■ |
| <b>K</b> | 1.1              |                    |                    |                    |                    |  |   |   |   |
|          | 1.2              |                    |                    |                    |                    |  |   |   |   |
|          | 2.1              |                    |                    |                    |                    |  |   |   |   |
|          | 2.2              |                    |                    |                    |                    |  |   |   |   |
|          | 3.1              |                    |                    |                    |                    |  |   |   |   |
|          | 3.2              |                    |                    |                    |                    |  |   |   |   |
|          | 4.1              |                    |                    |                    |                    |  |   |   |   |
| 4.2      |                  |                    |                    |                    |                    |  |   |   |   |
| <b>N</b> | 1.1              | 280                | $0,006 \times d_1$ | 400                | $0,006 \times d_1$ |  |   |   | ■ |
|          | 1.2              | 200                | $0,005 \times d_1$ | 280                | $0,005 \times d_1$ |  |   |   | ■ |
|          | 1.3              | 140                | $0,004 \times d_1$ | 200                | $0,004 \times d_1$ |  |   |   | ■ |
|          | 1.4              |                    |                    |                    |                    |  |   |   |   |
|          | 1.5              |                    |                    |                    |                    |  |   |   |   |
|          | 1.6              |                    |                    |                    |                    |  |   |   |   |
|          | 2.1              |                    |                    |                    |                    |  |   |   |   |
|          | 2.2              |                    |                    |                    |                    |  |   |   |   |
|          | 2.3              |                    |                    |                    |                    |  |   |   |   |
|          | 2.4              |                    |                    |                    |                    |  |   |   |   |
|          | 2.5              |                    |                    |                    |                    |  |   |   |   |
|          | 2.6              |                    |                    |                    |                    |  |   |   |   |
|          | 2.7              |                    |                    |                    |                    |  |   |   |   |
|          | 2.8              |                    |                    |                    |                    |  |   |   |   |
|          | 3.1              |                    |                    |                    |                    |  |   |   |   |
|          | 3.2              |                    |                    |                    |                    |  |   |   |   |
| 4.1      |                  |                    |                    |                    |                    |  |   |   |   |
| 4.2      |                  |                    |                    |                    |                    |  |   |   |   |
| 4.3      |                  |                    |                    |                    |                    |  |   |   |   |
| 4.4      |                  |                    |                    |                    |                    |  |   |   |   |
| 5.1      |                  |                    |                    |                    |                    |  |   |   |   |
| 5.2      |                  |                    |                    |                    |                    |  |   |   |   |
| 5.3      |                  |                    |                    |                    |                    |  |   |   |   |
| <b>S</b> | 1.1              | 90                 | $0,002 \times d_1$ | 120                | $0,004 \times d_1$ |  |   |   | ■ |
|          | 1.2              | 75                 | $0,002 \times d_1$ | 100                | $0,003 \times d_1$ |  |   |   | ■ |
|          | 1.3              | 45                 | $0,002 \times d_1$ | 60                 | $0,002 \times d_1$ |  |   |   | ■ |
|          | 2.1              |                    |                    |                    |                    |  |   |   |   |
|          | 2.2              | 25                 | $0,002 \times d_1$ | 30                 | $0,002 \times d_1$ |  |   |   | ■ |
|          | 2.3              | 25                 | $0,002 \times d_1$ | 30                 | $0,002 \times d_1$ |  |   |   | ■ |
|          | 2.4              | 25                 | $0,002 \times d_1$ | 30                 | $0,002 \times d_1$ |  |   |   | ■ |
| 2.5      | 15               | $0,002 \times d_1$ | 20                 | $0,002 \times d_1$ |                    |  |   | ■ |   |
| 2.6      | 25               | $0,002 \times d_1$ | 30                 | $0,002 \times d_1$ |                    |  |   | ■ |   |
| <b>H</b> | 1.1              |                    |                    |                    |                    |  |   |   |   |
|          | 1.2              |                    |                    |                    |                    |  |   |   |   |
|          | 1.3              |                    |                    |                    |                    |  |   |   |   |
|          | 1.4              |                    |                    |                    |                    |  |   |   |   |
|          | 1.5              |                    |                    |                    |                    |  |   |   |   |

$v_c$  = Schnittgeschwindigkeit · Cutting speed  
 $f_z$  = Vorschub pro Zahn · Feed per tooth

■ = sehr gut geeignet · very suitable  
□ = gut geeignet · suitable

- Hochleistungswerkzeug
- Mit 4 Schneiden
- Ungleiche Teilung
- Vibrationsarme Bearbeitung
- Hocheffiziente Schlichtbearbeitung
- Formtoleranz  $\pm 0,01$  mm

- High performance tool
- With 4 flutes
- Variable spacing
- Low-vibration machining
- Highly efficient finishing
- Form tolerance  $\pm 0.01$  mm

**N**

**HM**   **ICR**

**DIN 6535**  
HA  
HB

**Form**  
 $\pm 0,01$

**30°**

Tropfenform – ER  
Oval Form – ER



Allround

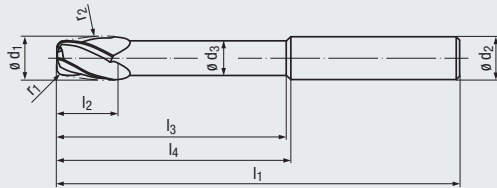
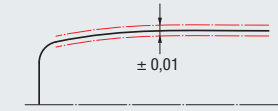

**Beschichtung · Coating**

**Einsatzgebiete – Material (siehe Seite 4)**

- Speziell für hochfeste Werkstoffe geeignet
- Auch für Nickel-Basis-Legierungen einsetzbar
- Für die Zerspaltung von Titan-Legierungen geeignet
- Einsatz in allen Turbinenwerkstoffen möglich
- Optimiert zur Fertigbearbeitung von Impellern und Integrated Bladed Rotors (IBR) aus Aluminium, Titan und Inconel

**Applications – material (see page 4)**

- Especially suitable for high-strength materials
- Also suitable in nickel-base alloys
- For the machining of titanium alloys
- Suitable in all turbine materials
- Optimised for finishing Impellers and Integrated Bladed Rotors (IBR) made from aluminium, titanium and Inconel

**ALCR**

- P** 1.1-5.1
- M** 1.1-4.1
- N** 1.1-1.3
- S** 1.1-1.3
- S** 2.2-2.6

**Bestell-Code · Order code**

| $d_1$ | $r_1$ | $r_2$ | $l_2$ | $l_1$ | $l_3$ | $l_4$ | $\varnothing d_3$ | $\varnothing d_2$<br>h6 | Z<br>(Flutes) | Dimens.-<br>Code | 3554LZ |  |  |
|-------|-------|-------|-------|-------|-------|-------|-------------------|-------------------------|---------------|------------------|--------|--|--|
| 8     | 1     | 40    | 12    | 80    | 42    | 44    | 7                 | 8                       | 4             | .08040A          | ●      |  |  |
| 10    | 1,5   | 45    | 12    | 95    | 52    | 55    | 8,5               | 10                      | 4             | .10045A          | ●      |  |  |
| 12    | 2     | 50    | 14    | 100   | 61    | 65    | 10                | 12                      | 4             | .12050A          | ●      |  |  |
| 16    | 2     | 60    | 18    | 128   | 76    | 80    | 14                | 16                      | 4             | .16060A          | ●      |  |  |



**Kreissegment-Fräser mit Tropfenform – ER**  
Circle segment end mills with oval form – ER

**N**

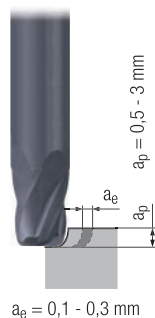

Gültig für · Valid for  
3554LZ

|          |     | $v_c$<br>[m/min]   | $f_z$<br>[mm]      |  |   | MMS<br>MQL |   |
|----------|-----|--------------------|--------------------|--|---|------------|---|
| <b>P</b> | 1.1 | 200                | $0,005 \times d_1$ |  | ■ | □          | ■ |
|          | 2.1 | 180                | $0,004 \times d_1$ |  | ■ | □          | ■ |
|          | 3.1 | 160                | $0,004 \times d_1$ |  | ■ | □          | ■ |
|          | 4.1 | 140                | $0,003 \times d_1$ |  | ■ | □          | ■ |
|          | 5.1 | 120                | $0,003 \times d_1$ |  | ■ | □          | ■ |
| <b>M</b> | 1.1 | 120                | $0,005 \times d_1$ |  |   |            | ■ |
|          | 2.1 | 100                | $0,004 \times d_1$ |  |   |            | ■ |
|          | 3.1 | 80                 | $0,003 \times d_1$ |  |   |            | ■ |
|          | 4.1 | 80                 | $0,003 \times d_1$ |  |   |            | ■ |
| <b>K</b> | 1.1 |                    |                    |  |   |            |   |
|          | 1.2 |                    |                    |  |   |            |   |
|          | 2.1 |                    |                    |  |   |            |   |
|          | 2.2 |                    |                    |  |   |            |   |
|          | 3.1 |                    |                    |  |   |            |   |
|          | 3.2 |                    |                    |  |   |            |   |
|          | 4.1 |                    |                    |  |   |            |   |
| <b>N</b> | 1.1 | 400                | $0,006 \times d_1$ |  |   |            | ■ |
|          | 1.2 | 280                | $0,005 \times d_1$ |  |   |            | ■ |
|          | 1.3 | 200                | $0,004 \times d_1$ |  |   |            | ■ |
|          | 1.4 |                    |                    |  |   |            |   |
|          | 1.5 |                    |                    |  |   |            |   |
|          | 1.6 |                    |                    |  |   |            |   |
|          | 2.1 |                    |                    |  |   |            |   |
|          | 2.2 |                    |                    |  |   |            |   |
|          | 2.3 |                    |                    |  |   |            |   |
|          | 2.4 |                    |                    |  |   |            |   |
|          | 2.5 |                    |                    |  |   |            |   |
|          | 2.6 |                    |                    |  |   |            |   |
|          | 2.7 |                    |                    |  |   |            |   |
|          | 2.8 |                    |                    |  |   |            |   |
|          | 3.1 |                    |                    |  |   |            |   |
|          | 3.2 |                    |                    |  |   |            |   |
| 4.1      |     |                    |                    |  |   |            |   |
| 4.2      |     |                    |                    |  |   |            |   |
| 4.3      |     |                    |                    |  |   |            |   |
| 4.4      |     |                    |                    |  |   |            |   |
| 5.1      |     |                    |                    |  |   |            |   |
| 5.2      |     |                    |                    |  |   |            |   |
| 5.3      |     |                    |                    |  |   |            |   |
| <b>S</b> | 1.1 | 120                | $0,005 \times d_1$ |  |   |            | ■ |
|          | 1.2 | 100                | $0,004 \times d_1$ |  |   |            | ■ |
|          | 1.3 | 60                 | $0,003 \times d_1$ |  |   |            | ■ |
|          | 2.1 |                    |                    |  |   |            |   |
|          | 2.2 | 30                 | $0,003 \times d_1$ |  |   |            | ■ |
|          | 2.3 | 30                 | $0,002 \times d_1$ |  |   |            | ■ |
|          | 2.4 | 30                 | $0,003 \times d_1$ |  |   |            | ■ |
| 2.5      | 20  | $0,002 \times d_1$ |                    |  |   | ■          |   |
| 2.6      | 30  | $0,002 \times d_1$ |                    |  |   | ■          |   |
| <b>H</b> | 1.1 |                    |                    |  |   |            |   |
|          | 1.2 |                    |                    |  |   |            |   |
|          | 1.3 |                    |                    |  |   |            |   |
|          | 1.4 |                    |                    |  |   |            |   |
|          | 1.5 |                    |                    |  |   |            |   |

$v_c$  = Schnittgeschwindigkeit · Cutting speed  
 $f_z$  = Vorschub pro Zahn · Feed per tooth

■ = sehr gut geeignet · very suitable  
□ = gut geeignet · suitable

- Hochleistungswerkzeug
- Mit 4 Schneiden
- Vibrationsarme Bearbeitung
- Hocheffiziente Schlichtbearbeitung
- Formtoleranz  $\pm 0,01$  mm
- High performance tool
- With 4 flutes
- Low-vibration machining
- Highly efficient finishing
- Form tolerance  $\pm 0.01$  mm

**N**

**HM**

DIN 6535



Form

$\pm 0,01$

30°



Optional



**Tonnenform – ER**  
**Barrel Form – ER**



**Allround**

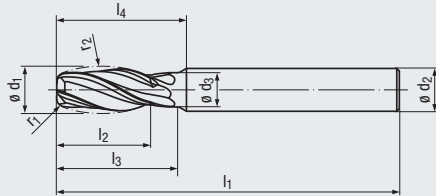
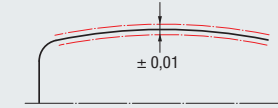

**Beschichtung · Coating**

**Einsatzgebiete – Material (siehe Seite 4)**

- Speziell für hochfeste Werkstoffe geeignet
- In fast allen Werkstoffen einsetzbar
- Zum HSC-Schlichten geeignet

**Applications – material (see page 4)**

- Especially suitable for high-strength materials
- For almost all materials
- Suitable for HSC finishing

**ALCR**

|          |         |              |
|----------|---------|--------------|
| <b>P</b> | 1.1-5.1 |              |
| <b>M</b> | 1.1-2.1 | 3.1-4.1      |
| <b>K</b> | 1.1-2.1 | 2.2          |
| <b>K</b> | 3.1-4.1 | 4.2          |
| <b>N</b> | 1.1-1.4 |              |
| <b>N</b> | 2.1-3.2 | 4.1-4.2, 5.2 |
| <b>S</b> | 1.1-2.2 | 2.3          |
| <b>S</b> | 2.4     | 2.5-2.6      |
| <b>H</b> | 1.1-1.2 |              |

**Bestell-Code · Order code**

**3542L**

| d <sub>1</sub> | r <sub>1</sub> | r <sub>2</sub> | l <sub>2</sub> | l <sub>3</sub> | l <sub>1</sub> | ∅ d <sub>3</sub> | l <sub>4</sub> | ∅ d <sub>2</sub><br>h6 | Z<br>(Flutes) | Dimens.-<br>Code |
|----------------|----------------|----------------|----------------|----------------|----------------|------------------|----------------|------------------------|---------------|------------------|
| <b>10</b>      | 2              | 50             | 21             | 28             | 80             | 8                | 30             | 10                     | <b>4</b>      | <b>.10050A</b>   |

**Baumaße für Werkzeugdatenbank**  
**Dimensions for tool database**

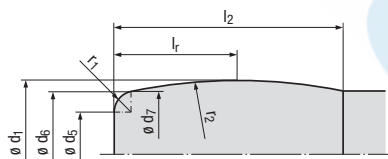

| d <sub>1</sub> | r <sub>1</sub> | r <sub>2</sub> | l <sub>2</sub> | l <sub>r</sub> | ∅ d <sub>5</sub> | ∅ d <sub>6</sub> | ∅ d <sub>7</sub> |
|----------------|----------------|----------------|----------------|----------------|------------------|------------------|------------------|
| <b>10</b>      | 2              | 50             | 21             | 11,747         | 4                | 7,917            | 8                |

$l_r = r_2$  trifft tangential (theoretisch) auf  $d_1$   
 $r_2$  is (theoretically) tangential to  $d_1$

$d_6 =$  Tangentialpunkt von  $r_1$  und  $r_2$   
Tangent point of  $r_1$  and  $r_2$

$d_7 = d_5 + 2 \times r_1$

**EMUGE-FRANKEN-Werkzeuge sind bereit für Industrie 4.0.**

Ab sofort steht der digitale Zwilling zu vielen unserer Katalogwerkzeuge für Sie zum Download auf unserer Homepage bereit.

**EMUGE-FRANKEN tools are ready for Industry 4.0.**

From now on the digital twin created for a wide variety of our catalogue tools can be downloaded directly from our homepage.

[tooldata.ef-apps.de](http://tooldata.ef-apps.de)

**Hartmetall-Kreissegment-Fräser mit Tonnenform – ER**  
Solid carbide circle segment end mill with barrel form – ER

**N**

Gültig für · Valid for  
3542L



Aufmaß · Allowance  
0,05 - 0,1 mm



Aufmaß · Allowance  
0,1 - 0,2 mm

Für die Berechnung der Drehzahl n muss mit dem Durchmesser d<sub>1</sub> gerechnet werden.

In order to calculate the rotational speed n, the diameter d<sub>1</sub> has to be used.



|          | V <sub>c</sub><br>[m/min] | f <sub>z</sub><br>[mm] | V <sub>c</sub><br>[m/min] | f <sub>z</sub><br>[mm] |                        |                          |                                     |                                     |                                     |
|----------|---------------------------|------------------------|---------------------------|------------------------|------------------------|--------------------------|-------------------------------------|-------------------------------------|-------------------------------------|
| <b>P</b> | 1.1                       | 420                    | 0,004 x d <sub>1</sub>    | 420                    | 0,003 x d <sub>1</sub> | <input type="checkbox"/> | <input checked="" type="checkbox"/> | <input type="checkbox"/>            | <input checked="" type="checkbox"/> |
|          | 2.1                       | 375                    | 0,004 x d <sub>1</sub>    | 375                    | 0,003 x d <sub>1</sub> | <input type="checkbox"/> | <input checked="" type="checkbox"/> | <input type="checkbox"/>            | <input checked="" type="checkbox"/> |
|          | 3.1                       | 315                    | 0,003 x d <sub>1</sub>    | 315                    | 0,003 x d <sub>1</sub> | <input type="checkbox"/> | <input checked="" type="checkbox"/> | <input type="checkbox"/>            | <input checked="" type="checkbox"/> |
|          | 4.1                       | 300                    | 0,003 x d <sub>1</sub>    | 300                    | 0,002 x d <sub>1</sub> | <input type="checkbox"/> | <input checked="" type="checkbox"/> |                                     |                                     |
|          | 5.1                       | 270                    | 0,003 x d <sub>1</sub>    | 270                    | 0,002 x d <sub>1</sub> | <input type="checkbox"/> | <input checked="" type="checkbox"/> |                                     |                                     |
| <b>M</b> | 1.1                       | 150                    | 0,005 x d <sub>1</sub>    | 150                    | 0,003 x d <sub>1</sub> |                          |                                     | <input type="checkbox"/>            | <input checked="" type="checkbox"/> |
|          | 2.1                       | 120                    | 0,005 x d <sub>1</sub>    | 120                    | 0,003 x d <sub>1</sub> |                          |                                     | <input type="checkbox"/>            | <input checked="" type="checkbox"/> |
|          | 3.1                       | 90                     | 0,004 x d <sub>1</sub>    | 90                     | 0,002 x d <sub>1</sub> |                          |                                     | <input type="checkbox"/>            | <input checked="" type="checkbox"/> |
|          | 4.1                       | 60                     | 0,004 x d <sub>1</sub>    | 60                     | 0,002 x d <sub>1</sub> |                          |                                     | <input type="checkbox"/>            | <input checked="" type="checkbox"/> |
| <b>K</b> | 1.1                       | 280                    | 0,005 x d <sub>1</sub>    | 280                    | 0,004 x d <sub>1</sub> | <input type="checkbox"/> | <input checked="" type="checkbox"/> |                                     |                                     |
|          | 1.2                       | 280                    | 0,005 x d <sub>1</sub>    | 280                    | 0,004 x d <sub>1</sub> | <input type="checkbox"/> | <input checked="" type="checkbox"/> |                                     |                                     |
|          | 2.1                       | 250                    | 0,004 x d <sub>1</sub>    | 250                    | 0,003 x d <sub>1</sub> | <input type="checkbox"/> | <input checked="" type="checkbox"/> |                                     |                                     |
|          | 2.2                       | 250                    | 0,004 x d <sub>1</sub>    | 250                    | 0,003 x d <sub>1</sub> | <input type="checkbox"/> | <input checked="" type="checkbox"/> |                                     |                                     |
|          | 3.1                       | 210                    | 0,004 x d <sub>1</sub>    | 210                    | 0,003 x d <sub>1</sub> | <input type="checkbox"/> | <input checked="" type="checkbox"/> |                                     |                                     |
|          | 3.2                       | 210                    | 0,004 x d <sub>1</sub>    | 210                    | 0,003 x d <sub>1</sub> | <input type="checkbox"/> | <input checked="" type="checkbox"/> |                                     |                                     |
|          | 4.1                       | 180                    | 0,003 x d <sub>1</sub>    | 180                    | 0,002 x d <sub>1</sub> | <input type="checkbox"/> | <input checked="" type="checkbox"/> |                                     |                                     |
|          | 4.2                       | 140                    | 0,003 x d <sub>1</sub>    | 140                    | 0,002 x d <sub>1</sub> | <input type="checkbox"/> | <input checked="" type="checkbox"/> |                                     |                                     |
| <b>N</b> | 1.1                       | 600                    | 0,004 x d <sub>1</sub>    | 600                    | 0,003 x d <sub>1</sub> |                          |                                     | <input type="checkbox"/>            | <input checked="" type="checkbox"/> |
|          | 1.2                       | 600                    | 0,004 x d <sub>1</sub>    | 600                    | 0,003 x d <sub>1</sub> |                          |                                     | <input type="checkbox"/>            | <input checked="" type="checkbox"/> |
|          | 1.3                       | 600                    | 0,003 x d <sub>1</sub>    | 600                    | 0,002 x d <sub>1</sub> |                          |                                     | <input type="checkbox"/>            | <input checked="" type="checkbox"/> |
|          | 1.4                       | 410                    | 0,004 x d <sub>1</sub>    | 410                    | 0,003 x d <sub>1</sub> |                          |                                     | <input type="checkbox"/>            | <input checked="" type="checkbox"/> |
|          | 1.5                       |                        |                           |                        |                        |                          |                                     |                                     |                                     |
|          | 1.6                       |                        |                           |                        |                        |                          |                                     |                                     |                                     |
|          | 2.1                       | 270                    | 0,005 x d <sub>1</sub>    | 270                    | 0,004 x d <sub>1</sub> |                          |                                     | <input type="checkbox"/>            | <input checked="" type="checkbox"/> |
|          | 2.2                       | 270                    | 0,005 x d <sub>1</sub>    | 270                    | 0,004 x d <sub>1</sub> |                          |                                     | <input type="checkbox"/>            | <input checked="" type="checkbox"/> |
|          | 2.3                       | 270                    | 0,005 x d <sub>1</sub>    | 270                    | 0,004 x d <sub>1</sub> |                          | <input type="checkbox"/>            | <input type="checkbox"/>            | <input checked="" type="checkbox"/> |
|          | 2.4                       | 255                    | 0,004 x d <sub>1</sub>    | 255                    | 0,003 x d <sub>1</sub> |                          |                                     | <input type="checkbox"/>            | <input checked="" type="checkbox"/> |
|          | 2.5                       | 255                    | 0,004 x d <sub>1</sub>    | 255                    | 0,003 x d <sub>1</sub> |                          |                                     | <input type="checkbox"/>            | <input checked="" type="checkbox"/> |
|          | 2.6                       | 255                    | 0,004 x d <sub>1</sub>    | 255                    | 0,003 x d <sub>1</sub> |                          | <input type="checkbox"/>            | <input type="checkbox"/>            | <input checked="" type="checkbox"/> |
|          | 2.7                       | 150                    | 0,003 x d <sub>1</sub>    | 150                    | 0,002 x d <sub>1</sub> |                          |                                     | <input type="checkbox"/>            | <input checked="" type="checkbox"/> |
|          | 2.8                       | 150                    | 0,003 x d <sub>1</sub>    | 150                    | 0,002 x d <sub>1</sub> |                          |                                     | <input type="checkbox"/>            | <input checked="" type="checkbox"/> |
|          | 3.1                       | 410                    | 0,005 x d <sub>1</sub>    | 410                    | 0,004 x d <sub>1</sub> |                          |                                     | <input type="checkbox"/>            | <input checked="" type="checkbox"/> |
|          | 3.2                       | 410                    | 0,005 x d <sub>1</sub>    | 410                    | 0,004 x d <sub>1</sub> |                          |                                     | <input type="checkbox"/>            | <input checked="" type="checkbox"/> |
| 4.1      | 410                       | 0,005 x d <sub>1</sub> | 410                       | 0,004 x d <sub>1</sub> |                        | <input type="checkbox"/> | <input type="checkbox"/>            | <input checked="" type="checkbox"/> |                                     |
| 4.2      | 600                       | 0,005 x d <sub>1</sub> | 600                       | 0,004 x d <sub>1</sub> |                        |                          | <input type="checkbox"/>            | <input checked="" type="checkbox"/> |                                     |
| 4.3      |                           |                        |                           |                        |                        |                          |                                     |                                     |                                     |
| 4.4      |                           |                        |                           |                        |                        |                          |                                     |                                     |                                     |
| 5.1      |                           |                        |                           |                        |                        |                          |                                     |                                     |                                     |
| 5.2      | 150                       | 0,005 x d <sub>1</sub> | 150                       | 0,003 x d <sub>1</sub> |                        |                          |                                     | <input checked="" type="checkbox"/> |                                     |
| 5.3      |                           |                        |                           |                        |                        |                          |                                     |                                     |                                     |
| <b>S</b> | 1.1                       | 100                    | 0,006 x d <sub>1</sub>    | 100                    | 0,004 x d <sub>1</sub> |                          |                                     |                                     | <input checked="" type="checkbox"/> |
|          | 1.2                       | 80                     | 0,005 x d <sub>1</sub>    | 80                     | 0,003 x d <sub>1</sub> |                          |                                     |                                     | <input checked="" type="checkbox"/> |
|          | 1.3                       | 60                     | 0,005 x d <sub>1</sub>    | 60                     | 0,003 x d <sub>1</sub> |                          |                                     |                                     | <input checked="" type="checkbox"/> |
|          | 2.1                       | 80                     | 0,004 x d <sub>1</sub>    | 80                     | 0,002 x d <sub>1</sub> |                          |                                     |                                     | <input checked="" type="checkbox"/> |
|          | 2.2                       | 30                     | 0,004 x d <sub>1</sub>    | 30                     | 0,002 x d <sub>1</sub> |                          |                                     |                                     | <input checked="" type="checkbox"/> |
|          | 2.3                       | 30                     | 0,004 x d <sub>1</sub>    | 30                     | 0,002 x d <sub>1</sub> |                          |                                     |                                     | <input checked="" type="checkbox"/> |
|          | 2.4                       | 30                     | 0,004 x d <sub>1</sub>    | 30                     | 0,002 x d <sub>1</sub> |                          |                                     |                                     | <input checked="" type="checkbox"/> |
|          | 2.5                       | 30                     | 0,004 x d <sub>1</sub>    | 30                     | 0,002 x d <sub>1</sub> |                          |                                     |                                     | <input checked="" type="checkbox"/> |
| 2.6      | 30                        | 0,004 x d <sub>1</sub> | 30                        | 0,002 x d <sub>1</sub> |                        |                          |                                     | <input checked="" type="checkbox"/> |                                     |
| <b>H</b> | 1.1                       | 130                    | 0,005 x d <sub>1</sub>    | 130                    | 0,003 x d <sub>1</sub> | <input type="checkbox"/> | <input checked="" type="checkbox"/> |                                     |                                     |
|          | 1.2                       | 100                    | 0,005 x d <sub>1</sub>    | 100                    | 0,003 x d <sub>1</sub> | <input type="checkbox"/> | <input checked="" type="checkbox"/> |                                     |                                     |
|          | 1.3                       |                        |                           |                        |                        |                          |                                     |                                     |                                     |
|          | 1.4                       |                        |                           |                        |                        |                          |                                     |                                     |                                     |
|          | 1.5                       |                        |                           |                        |                        |                          |                                     |                                     |                                     |

v<sub>c</sub> = Schnittgeschwindigkeit · Cutting speed  
f<sub>z</sub> = Vorschub pro Zahn · Feed per tooth

■ = sehr gut geeignet · very suitable  
□ = gut geeignet · suitable

- Hochleistungswerkzeug
- Mit 3 oder 4 Schneiden
- Vibrationsarme Bearbeitung
- Hocheffiziente Schlichtbearbeitung
- Formtoleranz  $\pm 0,01$  mm
- High performance tool
- With 3 or 4 flutes
- Low-vibration machining
- Highly efficient finishing
- Form tolerance  $\pm 0.01$  mm

**N**

**HM**

DIN 6535  
HA  
HB

**Form**  
 $\pm 0,01$

30°

Optional

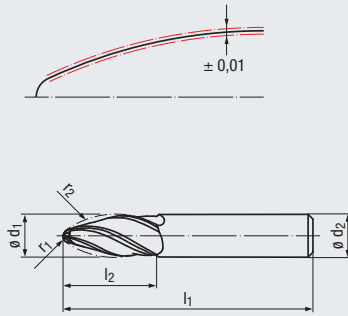

**Tropfenform – VR**  
Oval Form – VR



Allround

Beschichtung · Coating

Einsatzgebiete – Material (siehe Seite 4)

- Speziell für hochfeste Werkstoffe geeignet
- In fast allen Werkstoffen einsetzbar
- Zum HSC-Schlichten geeignet

Applications – material (see page 4)

- Especially suitable for high-strength materials
- For almost all materials
- Suitable for HSC finishing

**ALCR**

|   |         |              |
|---|---------|--------------|
| P | 1.1-5.1 |              |
| M | 1.1-2.1 | 3.1-4.1      |
| K | 1.1-2.1 | 2.2          |
| K | 3.1-4.1 | 4.2          |
| N | 1.1-1.4 |              |
| N | 2.1-3.2 | 4.1-4.2, 5.2 |
| S | 1.1-2.2 | 2.3          |
| S | 2.4     | 2.5-2.6      |
| H |         | 1.1-1.2      |

Bestell-Code · Order code

| d <sub>1</sub> | r <sub>1</sub> | r <sub>2</sub> | l <sub>2</sub> | l <sub>1</sub> | ∅ d <sub>2</sub><br>h6 | Z<br>(Flutes) | Dimens.-<br>Code | 3538L |  |  |  |
|----------------|----------------|----------------|----------------|----------------|------------------------|---------------|------------------|-------|--|--|--|
| 6              | 1              | 95             | 22             | 62             | 6                      | 3             | .06095A          | ●     |  |  |  |
| 8              | 1              | 90             | 25             | 68             | 8                      | 3             | .08090A          | ●     |  |  |  |
| 10             | 2              | 85             | 26             | 72             | 10                     | 4             | .10085A          | ●     |  |  |  |
| 12             | 2              | 80             | 28             | 83             | 12                     | 4             | .12080A          | ●     |  |  |  |
| 16             | 3              | 75             | 31             | 92             | 16                     | 4             | .16075A          | ●     |  |  |  |

**Bearbeitungsbeispiel**

**Bauteil:** Flansch einer Treibstoffleitung aus der Luftfahrtindustrie

**Anwendung:** Schlichtbearbeitung der runden Innenkontur sowie Teile der Außenkontur

**Machining example**

**Component:** Flange of a fuel pipe from the aviation industry

**Application:** Finishing of the round inner contour and parts of the outer contour



**Hartmetall-Kreissegment-Fräser mit Tropfenform – VR**  
Solid carbide circle segment end mills with oval form – VR

**N**

Gültig für · Valid for  
3538L



Aufmaß · Allowance  
0,05 - 0,1 mm



Aufmaß · Allowance  
0,1 - 0,2 mm



Aufmaß · Allowance  
0,2 - 0,3 mm

Für die Berechnung der Drehzahl n muss mit dem Durchmesser  $d_1$  gerechnet werden.

In order to calculate the rotational speed n, the diameter  $d_1$  has to be used.



|          |     | Aufmaß 0,05 - 0,1 mm |                    | Aufmaß 0,1 - 0,2 mm |                    | Aufmaß 0,2 - 0,3 mm |                    |                          |                                     | MMS MQL                             |                                     |
|----------|-----|----------------------|--------------------|---------------------|--------------------|---------------------|--------------------|--------------------------|-------------------------------------|-------------------------------------|-------------------------------------|
|          |     | $V_c$ [m/min]        | $f_z$ [mm]         | $V_c$ [m/min]       | $f_z$ [mm]         | $V_c$ [m/min]       | $f_z$ [mm]         |                          |                                     |                                     |                                     |
| <b>P</b> | 1.1 | 420                  | $0,004 \times d_1$ | 420                 | $0,003 \times d_1$ | 420                 | $0,003 \times d_1$ | <input type="checkbox"/> | <input checked="" type="checkbox"/> | <input type="checkbox"/>            | <input checked="" type="checkbox"/> |
|          | 2.1 | 375                  | $0,004 \times d_1$ | 375                 | $0,003 \times d_1$ | 375                 | $0,003 \times d_1$ | <input type="checkbox"/> | <input checked="" type="checkbox"/> | <input type="checkbox"/>            | <input checked="" type="checkbox"/> |
|          | 3.1 | 315                  | $0,003 \times d_1$ | 315                 | $0,003 \times d_1$ | 315                 | $0,002 \times d_1$ | <input type="checkbox"/> | <input checked="" type="checkbox"/> | <input type="checkbox"/>            | <input checked="" type="checkbox"/> |
|          | 4.1 | 300                  | $0,003 \times d_1$ | 300                 | $0,002 \times d_1$ | 300                 | $0,002 \times d_1$ | <input type="checkbox"/> | <input checked="" type="checkbox"/> |                                     |                                     |
|          | 5.1 | 270                  | $0,003 \times d_1$ | 270                 | $0,002 \times d_1$ | 270                 | $0,002 \times d_1$ | <input type="checkbox"/> | <input checked="" type="checkbox"/> |                                     |                                     |
| <b>M</b> | 1.1 | 150                  | $0,005 \times d_1$ | 150                 | $0,004 \times d_1$ | 150                 | $0,003 \times d_1$ |                          |                                     | <input type="checkbox"/>            | <input checked="" type="checkbox"/> |
|          | 2.1 | 120                  | $0,005 \times d_1$ | 120                 | $0,004 \times d_1$ | 120                 | $0,003 \times d_1$ |                          |                                     | <input type="checkbox"/>            | <input checked="" type="checkbox"/> |
|          | 3.1 | 90                   | $0,004 \times d_1$ | 90                  | $0,003 \times d_1$ | 90                  | $0,002 \times d_1$ |                          |                                     | <input type="checkbox"/>            | <input checked="" type="checkbox"/> |
|          | 4.1 | 60                   | $0,004 \times d_1$ | 60                  | $0,003 \times d_1$ | 60                  | $0,002 \times d_1$ |                          |                                     | <input type="checkbox"/>            | <input checked="" type="checkbox"/> |
| <b>K</b> | 1.1 | 280                  | $0,005 \times d_1$ | 280                 | $0,004 \times d_1$ | 280                 | $0,003 \times d_1$ | <input type="checkbox"/> | <input checked="" type="checkbox"/> |                                     |                                     |
|          | 1.2 | 280                  | $0,005 \times d_1$ | 280                 | $0,004 \times d_1$ | 280                 | $0,003 \times d_1$ | <input type="checkbox"/> | <input checked="" type="checkbox"/> |                                     |                                     |
|          | 2.1 | 250                  | $0,004 \times d_1$ | 250                 | $0,003 \times d_1$ | 250                 | $0,003 \times d_1$ | <input type="checkbox"/> | <input checked="" type="checkbox"/> |                                     |                                     |
|          | 2.2 | 250                  | $0,004 \times d_1$ | 250                 | $0,003 \times d_1$ | 250                 | $0,003 \times d_1$ | <input type="checkbox"/> | <input checked="" type="checkbox"/> |                                     |                                     |
|          | 3.1 | 210                  | $0,004 \times d_1$ | 210                 | $0,003 \times d_1$ | 210                 | $0,003 \times d_1$ | <input type="checkbox"/> | <input checked="" type="checkbox"/> |                                     |                                     |
|          | 3.2 | 210                  | $0,004 \times d_1$ | 210                 | $0,003 \times d_1$ | 210                 | $0,003 \times d_1$ | <input type="checkbox"/> | <input checked="" type="checkbox"/> |                                     |                                     |
|          | 4.1 | 180                  | $0,003 \times d_1$ | 180                 | $0,002 \times d_1$ | 180                 | $0,002 \times d_1$ | <input type="checkbox"/> | <input checked="" type="checkbox"/> |                                     |                                     |
|          | 4.2 | 140                  | $0,003 \times d_1$ | 140                 | $0,002 \times d_1$ | 140                 | $0,002 \times d_1$ | <input type="checkbox"/> | <input checked="" type="checkbox"/> |                                     |                                     |
| <b>N</b> | 1.1 | 600                  | $0,004 \times d_1$ | 600                 | $0,003 \times d_1$ | 600                 | $0,003 \times d_1$ |                          |                                     | <input type="checkbox"/>            | <input checked="" type="checkbox"/> |
|          | 1.2 | 600                  | $0,004 \times d_1$ | 600                 | $0,003 \times d_1$ | 600                 | $0,003 \times d_1$ |                          |                                     | <input type="checkbox"/>            | <input checked="" type="checkbox"/> |
|          | 1.3 | 600                  | $0,003 \times d_1$ | 600                 | $0,002 \times d_1$ | 600                 | $0,002 \times d_1$ |                          |                                     | <input type="checkbox"/>            | <input checked="" type="checkbox"/> |
|          | 1.4 | 410                  | $0,004 \times d_1$ | 410                 | $0,003 \times d_1$ | 410                 | $0,003 \times d_1$ |                          |                                     | <input type="checkbox"/>            | <input checked="" type="checkbox"/> |
|          | 1.5 |                      |                    |                     |                    |                     |                    |                          |                                     |                                     |                                     |
|          | 1.6 |                      |                    |                     |                    |                     |                    |                          |                                     |                                     |                                     |
|          | 2.1 | 270                  | $0,005 \times d_1$ | 270                 | $0,004 \times d_1$ | 270                 | $0,003 \times d_1$ |                          |                                     | <input type="checkbox"/>            | <input checked="" type="checkbox"/> |
|          | 2.2 | 270                  | $0,005 \times d_1$ | 270                 | $0,004 \times d_1$ | 270                 | $0,003 \times d_1$ |                          |                                     | <input type="checkbox"/>            | <input checked="" type="checkbox"/> |
|          | 2.3 | 270                  | $0,005 \times d_1$ | 270                 | $0,004 \times d_1$ | 270                 | $0,003 \times d_1$ |                          |                                     | <input type="checkbox"/>            | <input checked="" type="checkbox"/> |
|          | 2.4 | 255                  | $0,004 \times d_1$ | 255                 | $0,003 \times d_1$ | 255                 | $0,003 \times d_1$ | <input type="checkbox"/> | <input type="checkbox"/>            | <input type="checkbox"/>            | <input checked="" type="checkbox"/> |
|          | 2.5 | 255                  | $0,004 \times d_1$ | 255                 | $0,003 \times d_1$ | 255                 | $0,003 \times d_1$ |                          |                                     | <input type="checkbox"/>            | <input checked="" type="checkbox"/> |
|          | 2.6 | 255                  | $0,004 \times d_1$ | 255                 | $0,003 \times d_1$ | 255                 | $0,003 \times d_1$ |                          |                                     | <input type="checkbox"/>            | <input checked="" type="checkbox"/> |
|          | 2.7 | 150                  | $0,003 \times d_1$ | 150                 | $0,002 \times d_1$ | 150                 | $0,002 \times d_1$ | <input type="checkbox"/> | <input type="checkbox"/>            | <input type="checkbox"/>            | <input checked="" type="checkbox"/> |
|          | 2.8 | 150                  | $0,003 \times d_1$ | 150                 | $0,002 \times d_1$ | 150                 | $0,002 \times d_1$ |                          |                                     | <input type="checkbox"/>            | <input checked="" type="checkbox"/> |
|          | 3.1 | 410                  | $0,005 \times d_1$ | 410                 | $0,004 \times d_1$ | 410                 | $0,003 \times d_1$ |                          |                                     | <input type="checkbox"/>            | <input checked="" type="checkbox"/> |
|          | 3.2 | 410                  | $0,005 \times d_1$ | 410                 | $0,004 \times d_1$ | 410                 | $0,003 \times d_1$ |                          |                                     | <input type="checkbox"/>            | <input checked="" type="checkbox"/> |
| 4.1      | 410 | $0,005 \times d_1$   | 410                | $0,004 \times d_1$  | 410                | $0,003 \times d_1$  |                    |                          | <input type="checkbox"/>            | <input checked="" type="checkbox"/> |                                     |
| 4.2      | 600 | $0,005 \times d_1$   | 600                | $0,004 \times d_1$  | 600                | $0,003 \times d_1$  |                    |                          | <input type="checkbox"/>            | <input checked="" type="checkbox"/> |                                     |
| 4.3      |     |                      |                    |                     |                    |                     |                    |                          |                                     |                                     |                                     |
| 4.4      |     |                      |                    |                     |                    |                     |                    |                          |                                     |                                     |                                     |
| 5.1      |     |                      |                    |                     |                    |                     |                    |                          |                                     |                                     |                                     |
| 5.2      | 150 | $0,005 \times d_1$   | 150                | $0,004 \times d_1$  | 150                | $0,003 \times d_1$  |                    |                          |                                     | <input checked="" type="checkbox"/> |                                     |
| 5.3      |     |                      |                    |                     |                    |                     |                    |                          |                                     |                                     |                                     |
| <b>S</b> | 1.1 | 100                  | $0,006 \times d_1$ | 100                 | $0,005 \times d_1$ | 100                 | $0,004 \times d_1$ |                          |                                     |                                     | <input checked="" type="checkbox"/> |
|          | 1.2 | 80                   | $0,005 \times d_1$ | 80                  | $0,004 \times d_1$ | 80                  | $0,003 \times d_1$ |                          |                                     |                                     | <input checked="" type="checkbox"/> |
|          | 1.3 | 60                   | $0,005 \times d_1$ | 60                  | $0,004 \times d_1$ | 60                  | $0,003 \times d_1$ |                          |                                     |                                     | <input checked="" type="checkbox"/> |
|          | 2.1 | 80                   | $0,004 \times d_1$ | 80                  | $0,003 \times d_1$ | 80                  | $0,002 \times d_1$ |                          |                                     |                                     | <input checked="" type="checkbox"/> |
|          | 2.2 | 30                   | $0,004 \times d_1$ | 30                  | $0,003 \times d_1$ | 30                  | $0,002 \times d_1$ |                          |                                     |                                     | <input checked="" type="checkbox"/> |
|          | 2.3 | 30                   | $0,004 \times d_1$ | 30                  | $0,003 \times d_1$ | 30                  | $0,002 \times d_1$ |                          |                                     |                                     | <input checked="" type="checkbox"/> |
|          | 2.4 | 30                   | $0,004 \times d_1$ | 30                  | $0,003 \times d_1$ | 30                  | $0,002 \times d_1$ |                          |                                     |                                     | <input checked="" type="checkbox"/> |
|          | 2.5 | 30                   | $0,004 \times d_1$ | 30                  | $0,003 \times d_1$ | 30                  | $0,002 \times d_1$ |                          |                                     |                                     | <input checked="" type="checkbox"/> |
| 2.6      | 30  | $0,004 \times d_1$   | 30                 | $0,003 \times d_1$  | 30                 | $0,002 \times d_1$  |                    |                          |                                     | <input checked="" type="checkbox"/> |                                     |
| <b>H</b> | 1.1 | 130                  | $0,005 \times d_1$ | 130                 | $0,004 \times d_1$ | 130                 | $0,003 \times d_1$ | <input type="checkbox"/> | <input checked="" type="checkbox"/> |                                     |                                     |
|          | 1.2 | 100                  | $0,005 \times d_1$ | 100                 | $0,004 \times d_1$ | 100                 | $0,003 \times d_1$ | <input type="checkbox"/> | <input checked="" type="checkbox"/> |                                     |                                     |
|          | 1.3 |                      |                    |                     |                    |                     |                    |                          |                                     |                                     |                                     |
|          | 1.4 |                      |                    |                     |                    |                     |                    |                          |                                     |                                     |                                     |
|          | 1.5 |                      |                    |                     |                    |                     |                    |                          |                                     |                                     |                                     |

$v_c$  = Schnittgeschwindigkeit · Cutting speed  
 $f_z$  = Vorschub pro Zahn · Feed per tooth

= sehr gut geeignet · very suitable  
 = gut geeignet · suitable

- Hochleistungswerkzeug
- Mit 6 Schneiden
- Vibrationsarme Bearbeitung
- Hocheffiziente Schlichtbearbeitung
- Formtoleranz  $\pm 0,01$  mm
- High performance tool
- With 6 flutes
- Low-vibration machining
- Highly efficient finishing
- Form tolerance  $\pm 0.01$  mm

N

HM

DIN 6535



Form

$\pm 0,01$

30°



Optional



$\leq 60$   
HRC

Tropfenform – VR  
Oval Form – VR

new



Allround

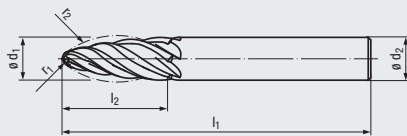
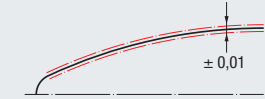

Beschichtung · Coating

Einsatzgebiete – Material (siehe Seite 4)

- Speziell für hochfeste Werkstoffe geeignet
- In fast allen Werkstoffen einsetzbar
- Hartbearbeitung bis 60 HRC möglich
- Zum HSC-Schlichten geeignet

Applications – material (see page 4)

- Especially suitable for high-strength materials
- For almost all materials
- Hard machining of up to 60 HRC
- Suitable for HSC finishing

ALCR

|   |         |              |
|---|---------|--------------|
| P | 1.1-5.1 |              |
| M | 1.1-2.1 | 3.1-4.1      |
| K | 1.1-2.1 | 2.2          |
| K | 3.1-4.1 | 4.2          |
| N | 1.1-1.4 |              |
| N | 2.1-3.2 | 4.1-4.2, 5.2 |
| S | 1.1-2.2 | 2.3          |
| S | 2.4     | 2.5-2.6      |
| H | 1.1-1.3 |              |

Bestell-Code · Order code

3539L

| d <sub>1</sub> | r <sub>1</sub> | r <sub>2</sub> | l <sub>2</sub> | l <sub>1</sub> | ø d <sub>2</sub><br>h6 | Z<br>(Flutes) | Dimens.-<br>Code |   |  |  |
|----------------|----------------|----------------|----------------|----------------|------------------------|---------------|------------------|---|--|--|
| 10             | 2              | 85             | 26             | 72             | 10                     | 6             | .10085A          | ● |  |  |
| 12             | 2              | 80             | 28             | 83             | 12                     | 6             | .12080A          | ● |  |  |
| 16             | 3              | 75             | 31             | 92             | 16                     | 6             | .16075A          | ● |  |  |

**Bearbeitungsbeispiel**

**Bauteil:** Lagerbock aus dem Maschinenbau

**Anwendung:** Komplette Schlichtbearbeitung der Außenkontur, Innenkontur und der Taschen

**Machining example**

**Component:** Bearing block from mechanical engineering

**Application:** Complete finishing of the the outer contour, inner contour and the pockets

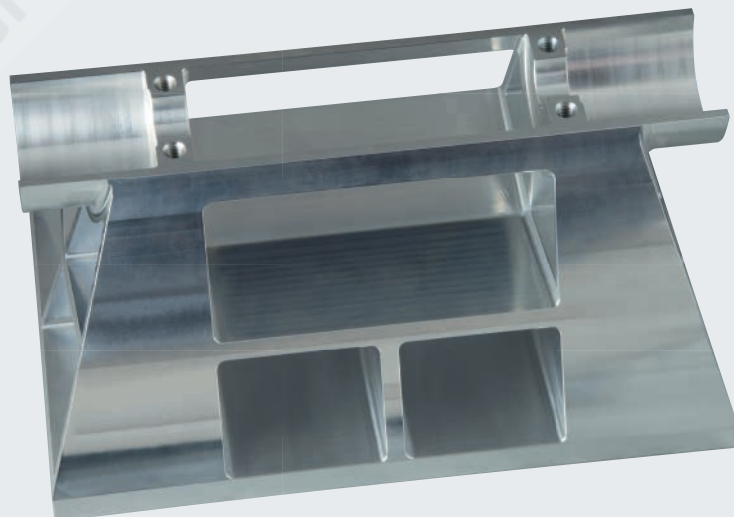



**Hartmetall-Kreissegment-Fräser mit Tropfenform – VR**  
Solid carbide circle segment end mills with oval form – VR

**N**



Aufmaß · Allowance  
0,05 - 0,1 mm



Aufmaß · Allowance  
0,1 - 0,2 mm

Gültig für · Valid for  
3539L

Für die Berechnung der Drehzahl n muss mit dem Durchmesser  $d_1$  gerechnet werden.

In order to calculate the rotational speed n, the diameter  $d_1$  has to be used.



|          | $V_c$<br>[m/min] | $f_z$<br>[mm] | $V_c$<br>[m/min] | $f_z$<br>[mm] |                          |                                     | MMS<br>MQL                          |                                     |
|----------|------------------|---------------|------------------|---------------|--------------------------|-------------------------------------|-------------------------------------|-------------------------------------|
| <b>P</b> | 1.1              | 0,003 x $d_1$ | 420              | 0,002 x $d_1$ | <input type="checkbox"/> | <input checked="" type="checkbox"/> | <input type="checkbox"/>            | <input checked="" type="checkbox"/> |
|          | 2.1              | 0,003 x $d_1$ | 375              | 0,002 x $d_1$ | <input type="checkbox"/> | <input checked="" type="checkbox"/> | <input type="checkbox"/>            | <input checked="" type="checkbox"/> |
|          | 3.1              | 0,002 x $d_1$ | 315              | 0,002 x $d_1$ | <input type="checkbox"/> | <input checked="" type="checkbox"/> | <input type="checkbox"/>            | <input checked="" type="checkbox"/> |
|          | 4.1              | 0,002 x $d_1$ | 300              | 0,001 x $d_1$ | <input type="checkbox"/> | <input checked="" type="checkbox"/> |                                     |                                     |
|          | 5.1              | 0,002 x $d_1$ | 270              | 0,001 x $d_1$ | <input type="checkbox"/> | <input checked="" type="checkbox"/> |                                     |                                     |
| <b>M</b> | 1.1              | 0,003 x $d_1$ | 150              | 0,002 x $d_1$ |                          |                                     | <input type="checkbox"/>            | <input checked="" type="checkbox"/> |
|          | 2.1              | 0,003 x $d_1$ | 120              | 0,002 x $d_1$ |                          |                                     | <input type="checkbox"/>            | <input checked="" type="checkbox"/> |
|          | 3.1              | 0,002 x $d_1$ | 90               | 0,001 x $d_1$ |                          |                                     | <input type="checkbox"/>            | <input checked="" type="checkbox"/> |
|          | 4.1              | 0,002 x $d_1$ | 60               | 0,001 x $d_1$ |                          |                                     | <input type="checkbox"/>            | <input checked="" type="checkbox"/> |
| <b>K</b> | 1.1              | 0,004 x $d_1$ | 280              | 0,003 x $d_1$ | <input type="checkbox"/> | <input checked="" type="checkbox"/> |                                     |                                     |
|          | 1.2              | 0,004 x $d_1$ | 280              | 0,003 x $d_1$ | <input type="checkbox"/> | <input checked="" type="checkbox"/> |                                     |                                     |
|          | 2.1              | 0,003 x $d_1$ | 250              | 0,002 x $d_1$ | <input type="checkbox"/> | <input checked="" type="checkbox"/> |                                     |                                     |
|          | 2.2              | 0,003 x $d_1$ | 250              | 0,002 x $d_1$ | <input type="checkbox"/> | <input checked="" type="checkbox"/> |                                     |                                     |
|          | 3.1              | 0,003 x $d_1$ | 210              | 0,002 x $d_1$ | <input type="checkbox"/> | <input checked="" type="checkbox"/> |                                     |                                     |
|          | 3.2              | 0,003 x $d_1$ | 210              | 0,002 x $d_1$ | <input type="checkbox"/> | <input checked="" type="checkbox"/> |                                     |                                     |
|          | 4.1              | 0,002 x $d_1$ | 180              | 0,001 x $d_1$ | <input type="checkbox"/> | <input checked="" type="checkbox"/> |                                     |                                     |
|          | 4.2              | 0,002 x $d_1$ | 140              | 0,001 x $d_1$ | <input type="checkbox"/> | <input checked="" type="checkbox"/> |                                     |                                     |
| <b>N</b> | 1.1              | 0,003 x $d_1$ | 600              | 0,002 x $d_1$ |                          |                                     | <input type="checkbox"/>            | <input checked="" type="checkbox"/> |
|          | 1.2              | 0,003 x $d_1$ | 600              | 0,002 x $d_1$ |                          |                                     | <input type="checkbox"/>            | <input checked="" type="checkbox"/> |
|          | 1.3              | 0,002 x $d_1$ | 600              | 0,001 x $d_1$ |                          |                                     | <input type="checkbox"/>            | <input checked="" type="checkbox"/> |
|          | 1.4              | 0,003 x $d_1$ | 410              | 0,002 x $d_1$ |                          |                                     | <input type="checkbox"/>            | <input checked="" type="checkbox"/> |
|          | 1.5              |               |                  |               |                          |                                     |                                     |                                     |
|          | 1.6              |               |                  |               |                          |                                     |                                     |                                     |
|          | 2.1              | 0,004 x $d_1$ | 270              | 0,003 x $d_1$ |                          |                                     | <input type="checkbox"/>            | <input checked="" type="checkbox"/> |
|          | 2.2              | 0,004 x $d_1$ | 270              | 0,003 x $d_1$ |                          |                                     | <input type="checkbox"/>            | <input checked="" type="checkbox"/> |
|          | 2.3              | 0,004 x $d_1$ | 270              | 0,003 x $d_1$ |                          | <input type="checkbox"/>            | <input type="checkbox"/>            | <input checked="" type="checkbox"/> |
|          | 2.4              | 0,003 x $d_1$ | 255              | 0,002 x $d_1$ |                          |                                     | <input type="checkbox"/>            | <input checked="" type="checkbox"/> |
|          | 2.5              | 0,003 x $d_1$ | 255              | 0,002 x $d_1$ |                          |                                     | <input type="checkbox"/>            | <input checked="" type="checkbox"/> |
|          | 2.6              | 0,003 x $d_1$ | 255              | 0,002 x $d_1$ |                          | <input type="checkbox"/>            | <input type="checkbox"/>            | <input checked="" type="checkbox"/> |
|          | 2.7              | 0,002 x $d_1$ | 150              | 0,001 x $d_1$ |                          |                                     | <input type="checkbox"/>            | <input checked="" type="checkbox"/> |
|          | 2.8              | 0,002 x $d_1$ | 150              | 0,001 x $d_1$ |                          |                                     | <input type="checkbox"/>            | <input checked="" type="checkbox"/> |
|          | 3.1              | 0,004 x $d_1$ | 410              | 0,003 x $d_1$ |                          |                                     | <input type="checkbox"/>            | <input checked="" type="checkbox"/> |
|          | 3.2              | 0,004 x $d_1$ | 410              | 0,003 x $d_1$ |                          |                                     | <input type="checkbox"/>            | <input checked="" type="checkbox"/> |
| 4.1      | 0,004 x $d_1$    | 410           | 0,003 x $d_1$    |               | <input type="checkbox"/> | <input type="checkbox"/>            | <input checked="" type="checkbox"/> |                                     |
| 4.2      | 0,004 x $d_1$    | 600           | 0,003 x $d_1$    |               |                          | <input type="checkbox"/>            | <input checked="" type="checkbox"/> |                                     |
| 4.3      |                  |               |                  |               |                          |                                     |                                     |                                     |
| 4.4      |                  |               |                  |               |                          |                                     |                                     |                                     |
| 5.1      |                  |               |                  |               |                          |                                     |                                     |                                     |
| 5.2      | 0,003 x $d_1$    | 150           | 0,002 x $d_1$    |               |                          |                                     | <input checked="" type="checkbox"/> |                                     |
| 5.3      |                  |               |                  |               |                          |                                     |                                     |                                     |
| <b>S</b> | 1.1              | 0,005 x $d_1$ | 100              | 0,004 x $d_1$ |                          |                                     |                                     | <input checked="" type="checkbox"/> |
|          | 1.2              | 0,004 x $d_1$ | 80               | 0,003 x $d_1$ |                          |                                     |                                     | <input checked="" type="checkbox"/> |
|          | 1.3              | 0,004 x $d_1$ | 60               | 0,003 x $d_1$ |                          |                                     |                                     | <input checked="" type="checkbox"/> |
|          | 2.1              | 0,003 x $d_1$ | 80               | 0,002 x $d_1$ |                          |                                     |                                     | <input checked="" type="checkbox"/> |
|          | 2.2              | 0,003 x $d_1$ | 30               | 0,002 x $d_1$ |                          |                                     |                                     | <input checked="" type="checkbox"/> |
|          | 2.3              | 0,003 x $d_1$ | 30               | 0,002 x $d_1$ |                          |                                     |                                     | <input checked="" type="checkbox"/> |
|          | 2.4              | 0,003 x $d_1$ | 30               | 0,002 x $d_1$ |                          |                                     |                                     | <input checked="" type="checkbox"/> |
| 2.5      | 0,003 x $d_1$    | 30            | 0,002 x $d_1$    |               |                          |                                     | <input checked="" type="checkbox"/> |                                     |
| 2.6      | 0,003 x $d_1$    | 30            | 0,002 x $d_1$    |               |                          |                                     | <input checked="" type="checkbox"/> |                                     |
| <b>H</b> | 1.1              | 0,004 x $d_1$ | 130              | 0,003 x $d_1$ | <input type="checkbox"/> | <input checked="" type="checkbox"/> |                                     |                                     |
|          | 1.2              | 0,004 x $d_1$ | 100              | 0,003 x $d_1$ | <input type="checkbox"/> | <input checked="" type="checkbox"/> |                                     |                                     |
|          | 1.3              | 0,003 x $d_1$ | 80               | 0,002 x $d_1$ | <input type="checkbox"/> | <input checked="" type="checkbox"/> |                                     |                                     |
|          | 1.4              |               |                  |               |                          |                                     |                                     |                                     |
|          | 1.5              |               |                  |               |                          |                                     |                                     |                                     |

$v_c$  = Schnittgeschwindigkeit · Cutting speed  
 $f_z$  = Vorschub pro Zahn · Feed per tooth

= sehr gut geeignet · very suitable  
 = gut geeignet · suitable

- Hochleistungswerkzeug
- Mit 2 oder 3 Schneiden
- Vibrationsarme Bearbeitung
- Hocheffiziente Schlichtbearbeitung
- Formtoleranz  $\pm 0,01$  mm
- High performance tool
- With 2 or 3 flutes
- Low-vibration machining
- Highly efficient finishing
- Form tolerance  $\pm 0.01$  mm

**N**

**HM**

DIN 6535 Form  $\pm 0,01$

HA HB

20-30°

Optional

### Kegelform – VR Taper Form – VR

Form A  
< 45°

Form B  
> 45°

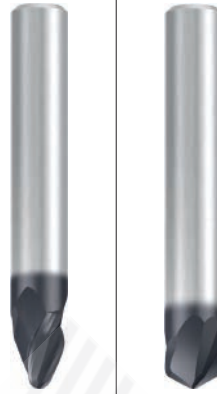

Allround

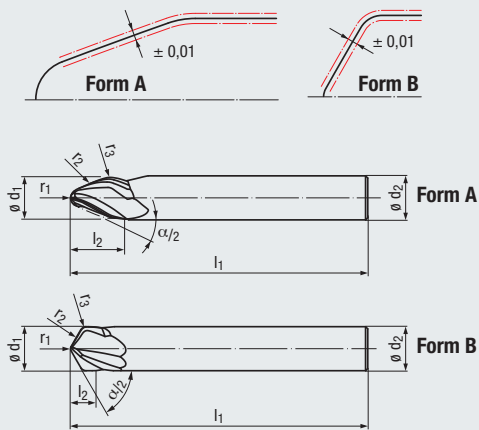

### Beschichtung · Coating

#### Einsatzgebiete – Material (siehe Seite 4)

- Speziell für hochfeste Werkstoffe geeignet
- In fast allen Werkstoffen einsetzbar
- Zum HSC-Schlichten geeignet
- Form A: bis 45° Anstellwinkel für steile Bereiche
- Form B: über 45° Anstellwinkel für flache Bereiche

#### Applications – material (see page 4)

- Especially suitable for high-strength materials
- For almost all materials
- Suitable for HSC finishing
- Form A: up to 45° tilt angle for steep areas
- Form B: more than 45° tilt angle for flat areas

### ALCR

|   |         |              |
|---|---------|--------------|
| P | 1.1-5.1 |              |
| M | 1.1-2.1 | 3.1-4.1      |
| K | 1.1-2.1 | 2.2          |
| K | 3.1-4.1 | 4.2          |
| N | 1.1-1.4 |              |
| N | 2.1-3.2 | 4.1-4.2, 5.2 |
| S | 1.1-2.2 | 2.3          |
| S | 2.4     | 2.5-2.6      |
| H |         | 1.1-1.2      |

### Bestell-Code · Order code

### 3540L

| $\alpha/2$ | $\varnothing d_1$ | $r_1$ | $r_2$ | $r_3$ | $l_2$ | $l_1$ | $\varnothing d_2$<br>h6 | Z<br>(Flutes) | Dimens.-<br>Code |   |   |  |
|------------|-------------------|-------|-------|-------|-------|-------|-------------------------|---------------|------------------|---|---|--|
| 12,5°      | 16                | 2     | 1000  | 5     | 31    | 108   | 16                      | 3             | .1610AA          | ● |   |  |
| 12,5°      | 16                | 4     | 1000  | 5     | 24    | 108   | 16                      | 3             | .1610AB          | ● |   |  |
| 17,5°      | 6                 | 1     | 250   | 3     | 9,5   | 62    | 6                       | 3             | .06250A          | ● |   |  |
| 20°        | 8                 | 1,5   | 250   | 4     | 10,5  | 68    | 8                       | 3             | .08250A          | ● |   |  |
| 20°        | 10                | 2     | 250   | 5     | 12,5  | 80    | 10                      | 3             | .10250A          | ● |   |  |
| 20°        | 12                | 3     | 250   | 6     | 13,5  | 93    | 12                      | 3             | .12250A          | ● |   |  |
| 20°        | 16                | 4     | 500   | 8     | 18,5  | 108   | 16                      | 3             | .16500A          | ● |   |  |
| 20°        | 16                | 4     | 1500  | 8     | 18,5  | 108   | 16                      | 3             | .1615AA          | ● |   |  |
| 42,5°      | 12                | 1     | 200   | 1     | 8     | 93    | 12                      | 3             | .12200A          | ● |   |  |
| 60°        | 10                | 1     | 200   | 1,5   | 6     | 80    | 10                      | 2             | .10200A          |   | ● |  |
| 70°        | 10                | 1     | 200   | 2     | 6     | 80    | 10                      | 2             | .10200B          |   | ● |  |



Hartmetall-Kreissegment-Fräser mit Kegelform – VR  
Solid carbide circle segment end mills with taper form – VR

N

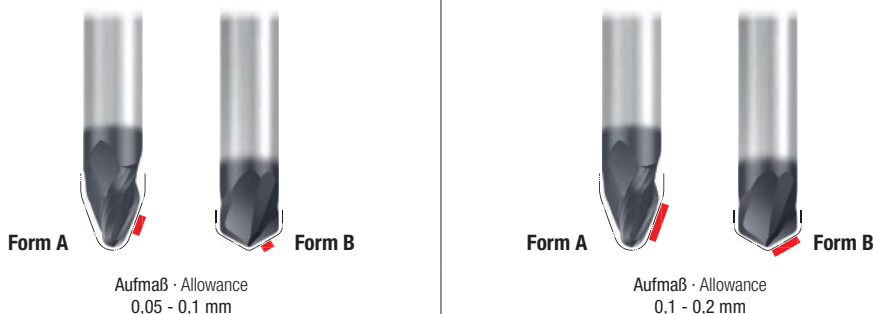

Gültig für · Valid for  
3540L

Für die Berechnung der Drehzahl n muss mit dem Durchmesser d<sub>1</sub> gerechnet werden.

In order to calculate the rotational speed n, the diameter d<sub>1</sub> has to be used.

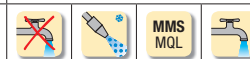

|     |     | Aufmaß - Allowance<br>0,05 - 0,1 mm |                        | Aufmaß - Allowance<br>0,1 - 0,2 mm |                        |                          |                                     |                                     |                                     |
|-----|-----|-------------------------------------|------------------------|------------------------------------|------------------------|--------------------------|-------------------------------------|-------------------------------------|-------------------------------------|
|     |     | V <sub>c</sub><br>[m/min]           | f <sub>z</sub><br>[mm] | V <sub>c</sub><br>[m/min]          | f <sub>z</sub><br>[mm] |                          |                                     |                                     |                                     |
| P   | 1.1 | 420                                 | 0,004 x d <sub>1</sub> | 420                                | 0,003 x d <sub>1</sub> | <input type="checkbox"/> | <input checked="" type="checkbox"/> | <input type="checkbox"/>            | <input checked="" type="checkbox"/> |
|     | 2.1 | 375                                 | 0,004 x d <sub>1</sub> | 375                                | 0,003 x d <sub>1</sub> | <input type="checkbox"/> | <input checked="" type="checkbox"/> | <input type="checkbox"/>            | <input checked="" type="checkbox"/> |
|     | 3.1 | 315                                 | 0,003 x d <sub>1</sub> | 315                                | 0,003 x d <sub>1</sub> | <input type="checkbox"/> | <input checked="" type="checkbox"/> | <input type="checkbox"/>            | <input checked="" type="checkbox"/> |
|     | 4.1 | 300                                 | 0,003 x d <sub>1</sub> | 300                                | 0,002 x d <sub>1</sub> | <input type="checkbox"/> | <input checked="" type="checkbox"/> |                                     |                                     |
|     | 5.1 | 270                                 | 0,003 x d <sub>1</sub> | 270                                | 0,002 x d <sub>1</sub> | <input type="checkbox"/> | <input checked="" type="checkbox"/> |                                     |                                     |
| M   | 1.1 | 150                                 | 0,004 x d <sub>1</sub> | 150                                | 0,003 x d <sub>1</sub> |                          |                                     | <input type="checkbox"/>            | <input checked="" type="checkbox"/> |
|     | 2.1 | 120                                 | 0,004 x d <sub>1</sub> | 120                                | 0,003 x d <sub>1</sub> |                          |                                     | <input type="checkbox"/>            | <input checked="" type="checkbox"/> |
|     | 3.1 | 90                                  | 0,003 x d <sub>1</sub> | 90                                 | 0,002 x d <sub>1</sub> |                          |                                     | <input type="checkbox"/>            | <input checked="" type="checkbox"/> |
|     | 4.1 | 60                                  | 0,003 x d <sub>1</sub> | 60                                 | 0,002 x d <sub>1</sub> |                          |                                     | <input type="checkbox"/>            | <input checked="" type="checkbox"/> |
| K   | 1.1 | 280                                 | 0,007 x d <sub>1</sub> | 280                                | 0,004 x d <sub>1</sub> | <input type="checkbox"/> | <input checked="" type="checkbox"/> |                                     |                                     |
|     | 1.2 | 280                                 | 0,007 x d <sub>1</sub> | 280                                | 0,004 x d <sub>1</sub> | <input type="checkbox"/> | <input checked="" type="checkbox"/> |                                     |                                     |
|     | 2.1 | 250                                 | 0,006 x d <sub>1</sub> | 250                                | 0,003 x d <sub>1</sub> | <input type="checkbox"/> | <input checked="" type="checkbox"/> |                                     |                                     |
|     | 2.2 | 250                                 | 0,006 x d <sub>1</sub> | 250                                | 0,003 x d <sub>1</sub> | <input type="checkbox"/> | <input checked="" type="checkbox"/> |                                     |                                     |
|     | 3.1 | 210                                 | 0,006 x d <sub>1</sub> | 210                                | 0,003 x d <sub>1</sub> | <input type="checkbox"/> | <input checked="" type="checkbox"/> |                                     |                                     |
|     | 3.2 | 210                                 | 0,006 x d <sub>1</sub> | 210                                | 0,003 x d <sub>1</sub> | <input type="checkbox"/> | <input checked="" type="checkbox"/> |                                     |                                     |
|     | 4.1 | 180                                 | 0,004 x d <sub>1</sub> | 180                                | 0,002 x d <sub>1</sub> | <input type="checkbox"/> | <input checked="" type="checkbox"/> |                                     |                                     |
|     | 4.2 | 140                                 | 0,003 x d <sub>1</sub> | 140                                | 0,002 x d <sub>1</sub> | <input type="checkbox"/> | <input checked="" type="checkbox"/> |                                     |                                     |
| N   | 1.1 | 600                                 | 0,004 x d <sub>1</sub> | 600                                | 0,003 x d <sub>1</sub> |                          |                                     | <input type="checkbox"/>            | <input checked="" type="checkbox"/> |
|     | 1.2 | 600                                 | 0,004 x d <sub>1</sub> | 600                                | 0,003 x d <sub>1</sub> |                          |                                     | <input type="checkbox"/>            | <input checked="" type="checkbox"/> |
|     | 1.3 | 600                                 | 0,003 x d <sub>1</sub> | 600                                | 0,002 x d <sub>1</sub> |                          |                                     | <input type="checkbox"/>            | <input checked="" type="checkbox"/> |
|     | 1.4 | 410                                 | 0,004 x d <sub>1</sub> | 410                                | 0,003 x d <sub>1</sub> |                          |                                     | <input type="checkbox"/>            | <input checked="" type="checkbox"/> |
|     | 1.5 |                                     |                        |                                    |                        |                          |                                     |                                     |                                     |
|     | 1.6 |                                     |                        |                                    |                        |                          |                                     |                                     |                                     |
|     | 2.1 | 270                                 | 0,005 x d <sub>1</sub> | 270                                | 0,004 x d <sub>1</sub> |                          |                                     | <input type="checkbox"/>            | <input checked="" type="checkbox"/> |
|     | 2.2 | 270                                 | 0,005 x d <sub>1</sub> | 270                                | 0,004 x d <sub>1</sub> |                          |                                     | <input type="checkbox"/>            | <input checked="" type="checkbox"/> |
|     | 2.3 | 270                                 | 0,005 x d <sub>1</sub> | 270                                | 0,004 x d <sub>1</sub> |                          | <input type="checkbox"/>            | <input type="checkbox"/>            | <input checked="" type="checkbox"/> |
|     | 2.4 | 255                                 | 0,004 x d <sub>1</sub> | 255                                | 0,003 x d <sub>1</sub> |                          | <input type="checkbox"/>            | <input type="checkbox"/>            | <input checked="" type="checkbox"/> |
|     | 2.5 | 255                                 | 0,004 x d <sub>1</sub> | 255                                | 0,003 x d <sub>1</sub> |                          | <input type="checkbox"/>            | <input type="checkbox"/>            | <input checked="" type="checkbox"/> |
|     | 2.6 | 255                                 | 0,004 x d <sub>1</sub> | 255                                | 0,003 x d <sub>1</sub> |                          | <input type="checkbox"/>            | <input type="checkbox"/>            | <input checked="" type="checkbox"/> |
|     | 2.7 | 150                                 | 0,003 x d <sub>1</sub> | 150                                | 0,002 x d <sub>1</sub> |                          | <input type="checkbox"/>            | <input type="checkbox"/>            | <input checked="" type="checkbox"/> |
|     | 2.8 | 150                                 | 0,003 x d <sub>1</sub> | 150                                | 0,002 x d <sub>1</sub> |                          | <input type="checkbox"/>            | <input type="checkbox"/>            | <input checked="" type="checkbox"/> |
|     | 3.1 | 410                                 | 0,005 x d <sub>1</sub> | 410                                | 0,004 x d <sub>1</sub> |                          |                                     | <input type="checkbox"/>            | <input checked="" type="checkbox"/> |
|     | 3.2 | 410                                 | 0,005 x d <sub>1</sub> | 410                                | 0,004 x d <sub>1</sub> |                          |                                     | <input type="checkbox"/>            | <input checked="" type="checkbox"/> |
|     | 4.1 | 410                                 | 0,005 x d <sub>1</sub> | 410                                | 0,004 x d <sub>1</sub> |                          | <input type="checkbox"/>            | <input type="checkbox"/>            | <input checked="" type="checkbox"/> |
|     | 4.2 | 600                                 | 0,005 x d <sub>1</sub> | 600                                | 0,004 x d <sub>1</sub> |                          | <input type="checkbox"/>            | <input type="checkbox"/>            | <input checked="" type="checkbox"/> |
|     | 4.3 |                                     |                        |                                    |                        |                          |                                     |                                     |                                     |
|     | 4.4 |                                     |                        |                                    |                        |                          |                                     |                                     |                                     |
| 5.1 |     |                                     |                        |                                    |                        |                          |                                     |                                     |                                     |
| 5.2 | 150 | 0,004 x d <sub>1</sub>              | 150                    | 0,003 x d <sub>1</sub>             |                        |                          |                                     | <input checked="" type="checkbox"/> |                                     |
| 5.3 |     |                                     |                        |                                    |                        |                          |                                     |                                     |                                     |
| S   | 1.1 | 100                                 | 0,005 x d <sub>1</sub> | 100                                | 0,004 x d <sub>1</sub> |                          |                                     |                                     | <input checked="" type="checkbox"/> |
|     | 1.2 | 80                                  | 0,004 x d <sub>1</sub> | 80                                 | 0,003 x d <sub>1</sub> |                          |                                     |                                     | <input checked="" type="checkbox"/> |
|     | 1.3 | 60                                  | 0,004 x d <sub>1</sub> | 60                                 | 0,003 x d <sub>1</sub> |                          |                                     |                                     | <input checked="" type="checkbox"/> |
|     | 2.1 | 80                                  | 0,003 x d <sub>1</sub> | 80                                 | 0,002 x d <sub>1</sub> |                          |                                     |                                     | <input checked="" type="checkbox"/> |
|     | 2.2 | 30                                  | 0,003 x d <sub>1</sub> | 30                                 | 0,002 x d <sub>1</sub> |                          |                                     |                                     | <input checked="" type="checkbox"/> |
|     | 2.3 | 30                                  | 0,003 x d <sub>1</sub> | 30                                 | 0,002 x d <sub>1</sub> |                          |                                     |                                     | <input checked="" type="checkbox"/> |
|     | 2.4 | 30                                  | 0,003 x d <sub>1</sub> | 30                                 | 0,002 x d <sub>1</sub> |                          |                                     |                                     | <input checked="" type="checkbox"/> |
|     | 2.5 | 30                                  | 0,003 x d <sub>1</sub> | 30                                 | 0,002 x d <sub>1</sub> |                          |                                     |                                     | <input checked="" type="checkbox"/> |
| 2.6 | 30  | 0,003 x d <sub>1</sub>              | 30                     | 0,002 x d <sub>1</sub>             |                        |                          |                                     | <input checked="" type="checkbox"/> |                                     |
| H   | 1.1 | 130                                 | 0,005 x d <sub>1</sub> | 130                                | 0,003 x d <sub>1</sub> | <input type="checkbox"/> | <input checked="" type="checkbox"/> |                                     |                                     |
|     | 1.2 | 100                                 | 0,005 x d <sub>1</sub> | 100                                | 0,003 x d <sub>1</sub> | <input type="checkbox"/> | <input checked="" type="checkbox"/> |                                     |                                     |
|     | 1.3 |                                     |                        |                                    |                        |                          |                                     |                                     |                                     |
|     | 1.4 |                                     |                        |                                    |                        |                          |                                     |                                     |                                     |
|     | 1.5 |                                     |                        |                                    |                        |                          |                                     |                                     |                                     |

v<sub>c</sub> = Schnittgeschwindigkeit · Cutting speed  
f<sub>z</sub> = Vorschub pro Zahn · Feed per tooth

■ = sehr gut geeignet · very suitable  
□ = gut geeignet · suitable

- Hochleistungswerkzeug
- Mit 4 oder 6 Schneiden
- Vibrationsarme Bearbeitung
- Hocheffiziente Schlichtbearbeitung
- Formtoleranz  $\pm 0,01$  mm
- High performance tool
- With 4 or 6 flutes
- Low-vibration machining
- Highly efficient finishing
- Form tolerance  $\pm 0.01$  mm

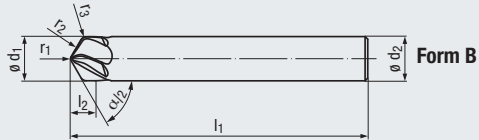
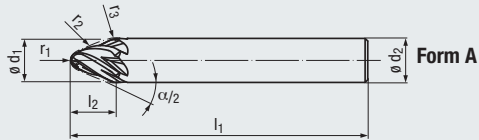

**N**

**HM**

DIN 6535 Form  $\pm 0,01$

HA HB

20-30°

Optional

$\leq 60$  HRC

### Kegelform – VR Taper Form – VR

Form A  
<math>< 45^\circ</math>

Form B  
>

new

new



Allround

### Beschichtung · Coating

#### Einsatzgebiete – Material (siehe Seite 4)

- Speziell für hochfeste Werkstoffe geeignet
- In fast allen Werkstoffen einsetzbar
- Hartbearbeitung bis 60 HRC möglich
- Zum HSC-Schlichten geeignet
- Form A: bis - Form B: über

#### Applications – material (see page 4)

- Especially suitable for high-strength materials
- For almost all materials
- Hard machining of up to 60 HRC
- Suitable for HSC finishing
- Form A: up to - Form B: more than

### ALCR

|   |         |              |
|---|---------|--------------|
| P | 1.1-5.1 |              |
| M | 1.1-2.1 | 3.1-4.1      |
| K | 1.1-2.1 | 2.2          |
| K | 3.1-4.1 | 4.2          |
| N | 1.1-1.4 |              |
| N | 2.1-3.2 | 4.1-4.2, 5.2 |
| S | 1.1-2.2 | 2.3          |
| S | 2.4     | 2.5-2.6      |
| H | 1.1-1.3 |              |

### Bestell-Code · Order code

### 3541L

| $\alpha/2$ | $\theta d_1$ | $r_1$ | $r_2$ | $r_3$ | $l_2$ | $l_1$ | $\theta d_2$<br>h6 | Z<br>(Flutes) | Dimens.-<br>Code |   |   |  |
|------------|--------------|-------|-------|-------|-------|-------|--------------------|---------------|------------------|---|---|--|
| 12,5°      | 16           | 2     | 1000  | 5     | 31    | 108   | 16                 | 6             | .1610AA          | ● |   |  |
| 12,5°      | 16           | 4     | 1000  | 5     | 24    | 108   | 16                 | 6             | .1610AB          | ● |   |  |
| 20°        | 10           | 2     | 250   | 5     | 12,5  | 80    | 10                 | 6             | .10250A          | ● |   |  |
| 20°        | 12           | 3     | 250   | 6     | 13,5  | 93    | 12                 | 6             | .12250A          | ● |   |  |
| 20°        | 16           | 4     | 500   | 8     | 18,5  | 108   | 16                 | 6             | .16500A          | ● |   |  |
| 20°        | 16           | 4     | 1500  | 8     | 18,5  | 108   | 16                 | 6             | .1615AA          | ● |   |  |
| 42,5°      | 12           | 1     | 200   | 1     | 8     | 93    | 12                 | 6             | .12200A          | ● |   |  |
| 60°        | 10           | 1     | 200   | 1,5   | 6     | 80    | 10                 | 4             | .10200A          |   | ● |  |
| 70°        | 10           | 1     | 200   | 2     | 6     | 80    | 10                 | 4             | .10200B          |   | ● |  |

**Nur mit Anstellwinkel  $\alpha/2$  einsetzen!**

Only use with tilt angle  $\alpha/2$ !

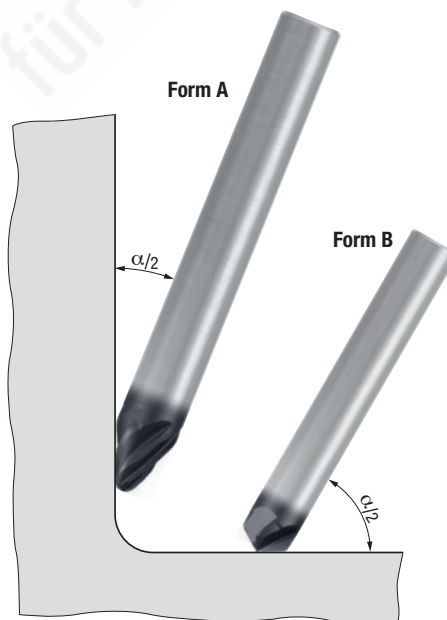

Hartmetall-Kreissegment-Fräser mit Kegelform – VR  
Solid carbide circle segment end mills with taper form – VR

N

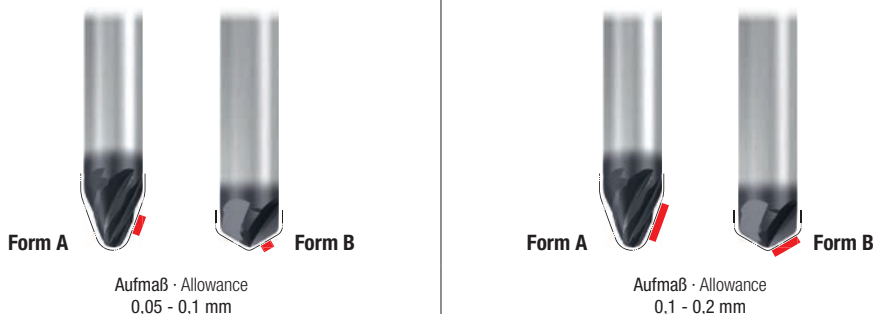

Gültig für · Valid for  
3541L

Für die Berechnung der Drehzahl n muss mit dem Durchmesser d<sub>1</sub> gerechnet werden.

In order to calculate the rotational speed n, the diameter d<sub>1</sub> has to be used.



|     |     | Aufmaß - Allowance<br>0,05 - 0,1 mm |                        | Aufmaß - Allowance<br>0,1 - 0,2 mm |                        |                          |                                     |                                     |                                     |
|-----|-----|-------------------------------------|------------------------|------------------------------------|------------------------|--------------------------|-------------------------------------|-------------------------------------|-------------------------------------|
|     |     | V <sub>c</sub><br>[m/min]           | f <sub>z</sub><br>[mm] | V <sub>c</sub><br>[m/min]          | f <sub>z</sub><br>[mm] |                          |                                     |                                     |                                     |
| P   | 1.1 | 420                                 | 0,003 x d <sub>1</sub> | 420                                | 0,002 x d <sub>1</sub> | <input type="checkbox"/> | <input checked="" type="checkbox"/> | <input type="checkbox"/>            | <input checked="" type="checkbox"/> |
|     | 2.1 | 375                                 | 0,003 x d <sub>1</sub> | 375                                | 0,002 x d <sub>1</sub> | <input type="checkbox"/> | <input checked="" type="checkbox"/> | <input type="checkbox"/>            | <input checked="" type="checkbox"/> |
|     | 3.1 | 315                                 | 0,002 x d <sub>1</sub> | 315                                | 0,002 x d <sub>1</sub> | <input type="checkbox"/> | <input checked="" type="checkbox"/> | <input type="checkbox"/>            | <input checked="" type="checkbox"/> |
|     | 4.1 | 300                                 | 0,002 x d <sub>1</sub> | 300                                | 0,001 x d <sub>1</sub> | <input type="checkbox"/> | <input checked="" type="checkbox"/> |                                     |                                     |
|     | 5.1 | 270                                 | 0,002 x d <sub>1</sub> | 270                                | 0,001 x d <sub>1</sub> | <input type="checkbox"/> | <input checked="" type="checkbox"/> |                                     |                                     |
| M   | 1.1 | 150                                 | 0,003 x d <sub>1</sub> | 150                                | 0,002 x d <sub>1</sub> |                          |                                     | <input type="checkbox"/>            | <input checked="" type="checkbox"/> |
|     | 2.1 | 120                                 | 0,003 x d <sub>1</sub> | 120                                | 0,002 x d <sub>1</sub> |                          |                                     | <input type="checkbox"/>            | <input checked="" type="checkbox"/> |
|     | 3.1 | 90                                  | 0,002 x d <sub>1</sub> | 90                                 | 0,001 x d <sub>1</sub> |                          |                                     | <input type="checkbox"/>            | <input checked="" type="checkbox"/> |
|     | 4.1 | 60                                  | 0,002 x d <sub>1</sub> | 60                                 | 0,001 x d <sub>1</sub> |                          |                                     | <input type="checkbox"/>            | <input checked="" type="checkbox"/> |
| K   | 1.1 | 280                                 | 0,004 x d <sub>1</sub> | 280                                | 0,003 x d <sub>1</sub> | <input type="checkbox"/> | <input checked="" type="checkbox"/> |                                     |                                     |
|     | 1.2 | 280                                 | 0,004 x d <sub>1</sub> | 280                                | 0,003 x d <sub>1</sub> | <input type="checkbox"/> | <input checked="" type="checkbox"/> |                                     |                                     |
|     | 2.1 | 250                                 | 0,003 x d <sub>1</sub> | 250                                | 0,002 x d <sub>1</sub> | <input type="checkbox"/> | <input checked="" type="checkbox"/> |                                     |                                     |
|     | 2.2 | 250                                 | 0,003 x d <sub>1</sub> | 250                                | 0,002 x d <sub>1</sub> | <input type="checkbox"/> | <input checked="" type="checkbox"/> |                                     |                                     |
|     | 3.1 | 210                                 | 0,003 x d <sub>1</sub> | 210                                | 0,002 x d <sub>1</sub> | <input type="checkbox"/> | <input checked="" type="checkbox"/> |                                     |                                     |
|     | 3.2 | 210                                 | 0,003 x d <sub>1</sub> | 210                                | 0,002 x d <sub>1</sub> | <input type="checkbox"/> | <input checked="" type="checkbox"/> |                                     |                                     |
|     | 4.1 | 180                                 | 0,002 x d <sub>1</sub> | 180                                | 0,001 x d <sub>1</sub> | <input type="checkbox"/> | <input checked="" type="checkbox"/> |                                     |                                     |
|     | 4.2 | 140                                 | 0,002 x d <sub>1</sub> | 140                                | 0,001 x d <sub>1</sub> | <input type="checkbox"/> | <input checked="" type="checkbox"/> |                                     |                                     |
| N   | 1.1 | 600                                 | 0,003 x d <sub>1</sub> | 600                                | 0,002 x d <sub>1</sub> |                          |                                     | <input type="checkbox"/>            | <input checked="" type="checkbox"/> |
|     | 1.2 | 600                                 | 0,003 x d <sub>1</sub> | 600                                | 0,002 x d <sub>1</sub> |                          |                                     | <input type="checkbox"/>            | <input checked="" type="checkbox"/> |
|     | 1.3 | 600                                 | 0,002 x d <sub>1</sub> | 600                                | 0,001 x d <sub>1</sub> |                          |                                     | <input type="checkbox"/>            | <input checked="" type="checkbox"/> |
|     | 1.4 | 410                                 | 0,003 x d <sub>1</sub> | 410                                | 0,002 x d <sub>1</sub> |                          |                                     | <input type="checkbox"/>            | <input checked="" type="checkbox"/> |
|     | 1.5 |                                     |                        |                                    |                        |                          |                                     |                                     |                                     |
|     | 1.6 |                                     |                        |                                    |                        |                          |                                     |                                     |                                     |
|     | 2.1 | 270                                 | 0,004 x d <sub>1</sub> | 270                                | 0,003 x d <sub>1</sub> |                          |                                     | <input type="checkbox"/>            | <input checked="" type="checkbox"/> |
|     | 2.2 | 270                                 | 0,004 x d <sub>1</sub> | 270                                | 0,003 x d <sub>1</sub> |                          |                                     | <input type="checkbox"/>            | <input checked="" type="checkbox"/> |
|     | 2.3 | 270                                 | 0,004 x d <sub>1</sub> | 270                                | 0,003 x d <sub>1</sub> |                          |                                     | <input type="checkbox"/>            | <input checked="" type="checkbox"/> |
|     | 2.4 | 255                                 | 0,003 x d <sub>1</sub> | 255                                | 0,002 x d <sub>1</sub> | <input type="checkbox"/> |                                     | <input type="checkbox"/>            | <input checked="" type="checkbox"/> |
|     | 2.5 | 255                                 | 0,003 x d <sub>1</sub> | 255                                | 0,002 x d <sub>1</sub> |                          |                                     | <input type="checkbox"/>            | <input checked="" type="checkbox"/> |
|     | 2.6 | 255                                 | 0,003 x d <sub>1</sub> | 255                                | 0,002 x d <sub>1</sub> | <input type="checkbox"/> |                                     | <input type="checkbox"/>            | <input checked="" type="checkbox"/> |
|     | 2.7 | 150                                 | 0,002 x d <sub>1</sub> | 150                                | 0,001 x d <sub>1</sub> |                          |                                     | <input type="checkbox"/>            | <input checked="" type="checkbox"/> |
|     | 2.8 | 150                                 | 0,002 x d <sub>1</sub> | 150                                | 0,001 x d <sub>1</sub> |                          |                                     | <input type="checkbox"/>            | <input checked="" type="checkbox"/> |
|     | 3.1 | 410                                 | 0,004 x d <sub>1</sub> | 410                                | 0,003 x d <sub>1</sub> |                          |                                     | <input type="checkbox"/>            | <input checked="" type="checkbox"/> |
|     | 3.2 | 410                                 | 0,004 x d <sub>1</sub> | 410                                | 0,003 x d <sub>1</sub> |                          |                                     | <input type="checkbox"/>            | <input checked="" type="checkbox"/> |
|     | 4.1 | 410                                 | 0,004 x d <sub>1</sub> | 410                                | 0,003 x d <sub>1</sub> |                          |                                     | <input type="checkbox"/>            | <input checked="" type="checkbox"/> |
|     | 4.2 | 600                                 | 0,004 x d <sub>1</sub> | 600                                | 0,003 x d <sub>1</sub> | <input type="checkbox"/> |                                     | <input type="checkbox"/>            | <input checked="" type="checkbox"/> |
|     | 4.3 |                                     |                        |                                    |                        |                          |                                     |                                     |                                     |
|     | 4.4 |                                     |                        |                                    |                        |                          |                                     |                                     |                                     |
| 5.1 |     |                                     |                        |                                    |                        |                          |                                     |                                     |                                     |
| 5.2 | 150 | 0,003 x d <sub>1</sub>              | 150                    | 0,002 x d <sub>1</sub>             |                        |                          |                                     | <input checked="" type="checkbox"/> |                                     |
| 5.3 |     |                                     |                        |                                    |                        |                          |                                     |                                     |                                     |
| S   | 1.1 | 100                                 | 0,005 x d <sub>1</sub> | 100                                | 0,004 x d <sub>1</sub> |                          |                                     |                                     | <input checked="" type="checkbox"/> |
|     | 1.2 | 80                                  | 0,004 x d <sub>1</sub> | 80                                 | 0,003 x d <sub>1</sub> |                          |                                     |                                     | <input checked="" type="checkbox"/> |
|     | 1.3 | 60                                  | 0,004 x d <sub>1</sub> | 60                                 | 0,003 x d <sub>1</sub> |                          |                                     |                                     | <input checked="" type="checkbox"/> |
|     | 2.1 | 80                                  | 0,003 x d <sub>1</sub> | 80                                 | 0,002 x d <sub>1</sub> |                          |                                     |                                     | <input checked="" type="checkbox"/> |
|     | 2.2 | 30                                  | 0,003 x d <sub>1</sub> | 30                                 | 0,002 x d <sub>1</sub> |                          |                                     |                                     | <input checked="" type="checkbox"/> |
|     | 2.3 | 30                                  | 0,003 x d <sub>1</sub> | 30                                 | 0,002 x d <sub>1</sub> |                          |                                     |                                     | <input checked="" type="checkbox"/> |
|     | 2.4 | 30                                  | 0,003 x d <sub>1</sub> | 30                                 | 0,002 x d <sub>1</sub> |                          |                                     |                                     | <input checked="" type="checkbox"/> |
|     | 2.5 | 30                                  | 0,003 x d <sub>1</sub> | 30                                 | 0,002 x d <sub>1</sub> |                          |                                     |                                     | <input checked="" type="checkbox"/> |
| 2.6 | 30  | 0,003 x d <sub>1</sub>              | 30                     | 0,002 x d <sub>1</sub>             |                        |                          |                                     | <input checked="" type="checkbox"/> |                                     |
| H   | 1.1 | 130                                 | 0,004 x d <sub>1</sub> | 130                                | 0,003 x d <sub>1</sub> | <input type="checkbox"/> | <input checked="" type="checkbox"/> |                                     |                                     |
|     | 1.2 | 100                                 | 0,004 x d <sub>1</sub> | 100                                | 0,003 x d <sub>1</sub> | <input type="checkbox"/> | <input checked="" type="checkbox"/> |                                     |                                     |
|     | 1.3 | 80                                  | 0,003 x d <sub>1</sub> | 80                                 | 0,002 x d <sub>1</sub> | <input type="checkbox"/> | <input checked="" type="checkbox"/> |                                     |                                     |
|     | 1.4 |                                     |                        |                                    |                        |                          |                                     |                                     |                                     |
|     | 1.5 |                                     |                        |                                    |                        |                          |                                     |                                     |                                     |

v<sub>c</sub> = Schnittgeschwindigkeit · Cutting speed  
f<sub>z</sub> = Vorschub pro Zahn · Feed per tooth

■ = sehr gut geeignet · very suitable  
□ = gut geeignet · suitable

- Hochleistungswerkzeug
- Mit 3 Schneiden
- Vibrationsarme Bearbeitung
- Hocheffiziente Schlichtbearbeitung
- Formtoleranz  $\pm 0,01$  mm
- High performance tool
- With 3 flutes
- Low-vibration machining
- Highly efficient finishing
- Form tolerance  $\pm 0.01$  mm

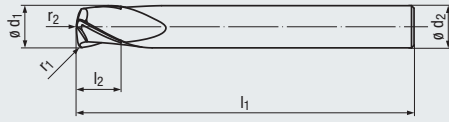
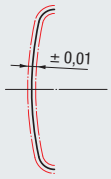

### Design I<sub>3</sub>:

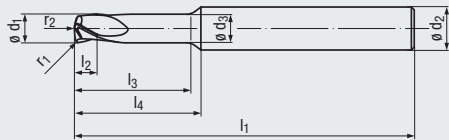

**N**

**HM**

DIN 6535  
HA  
HB

**Form**  
 $\pm 0,01$

30°

Optional

### Linsenform – ER Lens Form – ER



Allround

### Beschichtung · Coating

#### Einsatzgebiete – Material (siehe Seite 4)

- Speziell für hochfeste Werkstoffe geeignet
- In fast allen Werkstoffen einsetzbar
- Zum HSC-Schlichten geeignet

#### Applications – material (see page 4)

- Especially suitable for high-strength materials
- For almost all materials
- Suitable for HSC finishing

### ALCR

|   |         |         |
|---|---------|---------|
| P | 1.1-5.1 |         |
| M | 1.1-2.1 | 3.1-4.1 |
| K | 1.1-2.1 | 2.2     |
| K | 3.1-4.1 | 4.2     |
| N | 1.1-1.4 |         |
| N | 2.1-3.2 | 5.2     |
| S | 1.1-2.1 |         |

### Bestell-Code · Order code

3544L

| $\varnothing d_1$ | $r_1$ | $r_2$ | $l_2$ | $l_3$ | $l_1$ | $\varnothing d_3$ | $l_4$ | $\varnothing d_2$ | Z<br>(Flutes) | Dimens.-<br>Code |   |  |  |
|-------------------|-------|-------|-------|-------|-------|-------------------|-------|-------------------|---------------|------------------|---|--|--|
| 4                 | 0,25  | 6     | 4     | 18    | 62    | 4                 | 20    | 6                 | 3             | .04006A          | ● |  |  |
| 6                 | 0,5   | 10    | 6     | –     | 62    | –                 | –     | 6                 | 3             | .06010A          | ● |  |  |
| 8                 | 0,75  | 15    | 8     | –     | 68    | –                 | –     | 8                 | 3             | .08015A          | ● |  |  |
| 10                | 1     | 20    | 10    | –     | 80    | –                 | –     | 10                | 3             | .10020A          | ● |  |  |
| 12                | 1,25  | 25    | 12    | –     | 93    | –                 | –     | 12                | 3             | .12025A          | ● |  |  |

### Bearbeitungsbeispiel

**Bauteil:** Integralbauteil aus der Luftfahrtindustrie

**Anwendung:** Schlichtbearbeitung der tiefen Taschen und der Bodenflächen

### Machining example

**Component:** Integral component from the aviation industry

**Application:** Finishing of the deep pockets and the bottom surfaces



**Hartmetall-Kreissegment-Fräser mit Linsenform – ER**  
Solid carbide circle segment end mill with lens form – ER

**N**

**Gültig für · Valid for**  
3544L



Aufmaß · Allowance  
0,05 - 0,1 mm



Aufmaß · Allowance  
0,1 - 0,2 mm

Für die Berechnung der Drehzahl n muss mit dem Durchmesser  $d_1$  gerechnet werden.

In order to calculate the rotational speed n, the diameter  $d_1$  has to be used.



|          | $V_c$<br>[m/min] | $f_z$<br>[mm]      | $V_c$<br>[m/min]   | $f_z$<br>[mm]      |                    |                          | MMS<br>MQL                          |                                     |                                     |
|----------|------------------|--------------------|--------------------|--------------------|--------------------|--------------------------|-------------------------------------|-------------------------------------|-------------------------------------|
| <b>P</b> | 1.1              | 420                | $0,004 \times d_1$ | 420                | $0,003 \times d_1$ | <input type="checkbox"/> | <input checked="" type="checkbox"/> | <input type="checkbox"/>            | <input checked="" type="checkbox"/> |
|          | 2.1              | 375                | $0,004 \times d_1$ | 375                | $0,003 \times d_1$ | <input type="checkbox"/> | <input checked="" type="checkbox"/> | <input type="checkbox"/>            | <input checked="" type="checkbox"/> |
|          | 3.1              | 315                | $0,003 \times d_1$ | 315                | $0,003 \times d_1$ | <input type="checkbox"/> | <input checked="" type="checkbox"/> | <input type="checkbox"/>            | <input checked="" type="checkbox"/> |
|          | 4.1              | 300                | $0,003 \times d_1$ | 300                | $0,002 \times d_1$ | <input type="checkbox"/> | <input checked="" type="checkbox"/> |                                     |                                     |
|          | 5.1              | 270                | $0,003 \times d_1$ | 270                | $0,002 \times d_1$ | <input type="checkbox"/> | <input checked="" type="checkbox"/> |                                     |                                     |
| <b>M</b> | 1.1              | 150                | $0,005 \times d_1$ | 150                | $0,003 \times d_1$ |                          |                                     | <input type="checkbox"/>            | <input checked="" type="checkbox"/> |
|          | 2.1              | 120                | $0,005 \times d_1$ | 120                | $0,003 \times d_1$ |                          |                                     | <input type="checkbox"/>            | <input checked="" type="checkbox"/> |
|          | 3.1              | 90                 | $0,004 \times d_1$ | 90                 | $0,002 \times d_1$ |                          |                                     | <input type="checkbox"/>            | <input checked="" type="checkbox"/> |
|          | 4.1              | 60                 | $0,004 \times d_1$ | 60                 | $0,002 \times d_1$ |                          |                                     | <input type="checkbox"/>            | <input checked="" type="checkbox"/> |
| <b>K</b> | 1.1              | 300                | $0,005 \times d_1$ | 300                | $0,004 \times d_1$ | <input type="checkbox"/> | <input checked="" type="checkbox"/> |                                     |                                     |
|          | 1.2              | 300                | $0,005 \times d_1$ | 300                | $0,004 \times d_1$ | <input type="checkbox"/> | <input checked="" type="checkbox"/> |                                     |                                     |
|          | 2.1              | 270                | $0,004 \times d_1$ | 270                | $0,003 \times d_1$ | <input type="checkbox"/> | <input checked="" type="checkbox"/> |                                     |                                     |
|          | 2.2              | 270                | $0,004 \times d_1$ | 270                | $0,003 \times d_1$ | <input type="checkbox"/> | <input checked="" type="checkbox"/> |                                     |                                     |
|          | 3.1              | 220                | $0,004 \times d_1$ | 220                | $0,003 \times d_1$ | <input type="checkbox"/> | <input checked="" type="checkbox"/> |                                     |                                     |
|          | 3.2              | 220                | $0,004 \times d_1$ | 220                | $0,003 \times d_1$ | <input type="checkbox"/> | <input checked="" type="checkbox"/> |                                     |                                     |
|          | 4.1              | 200                | $0,003 \times d_1$ | 200                | $0,002 \times d_1$ | <input type="checkbox"/> | <input checked="" type="checkbox"/> |                                     |                                     |
|          | 4.2              | 150                | $0,003 \times d_1$ | 150                | $0,002 \times d_1$ | <input type="checkbox"/> | <input checked="" type="checkbox"/> |                                     |                                     |
| <b>N</b> | 1.1              | 900                | $0,004 \times d_1$ | 900                | $0,003 \times d_1$ |                          |                                     | <input type="checkbox"/>            | <input checked="" type="checkbox"/> |
|          | 1.2              | 900                | $0,004 \times d_1$ | 900                | $0,003 \times d_1$ |                          |                                     | <input type="checkbox"/>            | <input checked="" type="checkbox"/> |
|          | 1.3              | 900                | $0,003 \times d_1$ | 900                | $0,002 \times d_1$ |                          |                                     | <input type="checkbox"/>            | <input checked="" type="checkbox"/> |
|          | 1.4              | 600                | $0,004 \times d_1$ | 600                | $0,003 \times d_1$ |                          |                                     | <input type="checkbox"/>            | <input checked="" type="checkbox"/> |
|          | 1.5              |                    |                    |                    |                    |                          |                                     |                                     |                                     |
|          | 1.6              |                    |                    |                    |                    |                          |                                     |                                     |                                     |
|          | 2.1              | 270                | $0,004 \times d_1$ | 270                | $0,003 \times d_1$ |                          |                                     | <input type="checkbox"/>            | <input checked="" type="checkbox"/> |
|          | 2.2              | 270                | $0,004 \times d_1$ | 270                | $0,003 \times d_1$ |                          |                                     | <input type="checkbox"/>            | <input checked="" type="checkbox"/> |
|          | 2.3              | 270                | $0,004 \times d_1$ | 270                | $0,003 \times d_1$ |                          | <input type="checkbox"/>            | <input type="checkbox"/>            | <input checked="" type="checkbox"/> |
|          | 2.4              | 255                | $0,003 \times d_1$ | 255                | $0,002 \times d_1$ |                          | <input type="checkbox"/>            | <input type="checkbox"/>            | <input checked="" type="checkbox"/> |
|          | 2.5              | 255                | $0,003 \times d_1$ | 255                | $0,002 \times d_1$ |                          | <input type="checkbox"/>            | <input type="checkbox"/>            | <input checked="" type="checkbox"/> |
|          | 2.6              | 255                | $0,003 \times d_1$ | 255                | $0,002 \times d_1$ |                          | <input type="checkbox"/>            | <input type="checkbox"/>            | <input checked="" type="checkbox"/> |
|          | 2.7              | 150                | $0,003 \times d_1$ | 150                | $0,002 \times d_1$ |                          | <input type="checkbox"/>            | <input type="checkbox"/>            | <input checked="" type="checkbox"/> |
|          | 2.8              | 150                | $0,003 \times d_1$ | 150                | $0,002 \times d_1$ |                          | <input type="checkbox"/>            | <input type="checkbox"/>            | <input checked="" type="checkbox"/> |
|          | 3.1              | 600                | $0,004 \times d_1$ | 600                | $0,003 \times d_1$ |                          |                                     | <input type="checkbox"/>            | <input checked="" type="checkbox"/> |
|          | 3.2              | 600                | $0,004 \times d_1$ | 600                | $0,003 \times d_1$ |                          |                                     | <input type="checkbox"/>            | <input checked="" type="checkbox"/> |
| 4.1      |                  |                    |                    |                    |                    |                          |                                     |                                     |                                     |
| 4.2      |                  |                    |                    |                    |                    |                          |                                     |                                     |                                     |
| 4.3      |                  |                    |                    |                    |                    |                          |                                     |                                     |                                     |
| 4.4      |                  |                    |                    |                    |                    |                          |                                     |                                     |                                     |
| 5.1      |                  |                    |                    |                    |                    |                          |                                     |                                     |                                     |
| 5.2      | 150              | $0,005 \times d_1$ | 150                | $0,003 \times d_1$ |                    |                          |                                     | <input checked="" type="checkbox"/> |                                     |
| 5.3      |                  |                    |                    |                    |                    |                          |                                     |                                     |                                     |
| <b>S</b> | 1.1              | 150                | $0,006 \times d_1$ | 150                | $0,004 \times d_1$ |                          |                                     |                                     | <input checked="" type="checkbox"/> |
|          | 1.2              | 120                | $0,005 \times d_1$ | 120                | $0,003 \times d_1$ |                          |                                     |                                     | <input checked="" type="checkbox"/> |
|          | 1.3              | 90                 | $0,005 \times d_1$ | 90                 | $0,003 \times d_1$ |                          |                                     |                                     | <input checked="" type="checkbox"/> |
|          | 2.1              | 120                | $0,004 \times d_1$ | 120                | $0,002 \times d_1$ |                          |                                     |                                     | <input checked="" type="checkbox"/> |
|          | 2.2              |                    |                    |                    |                    |                          |                                     |                                     |                                     |
|          | 2.3              |                    |                    |                    |                    |                          |                                     |                                     |                                     |
| 2.4      |                  |                    |                    |                    |                    |                          |                                     |                                     |                                     |
| 2.5      |                  |                    |                    |                    |                    |                          |                                     |                                     |                                     |
| 2.6      |                  |                    |                    |                    |                    |                          |                                     |                                     |                                     |
| <b>H</b> | 1.1              |                    |                    |                    |                    |                          |                                     |                                     |                                     |
|          | 1.2              |                    |                    |                    |                    |                          |                                     |                                     |                                     |
|          | 1.3              |                    |                    |                    |                    |                          |                                     |                                     |                                     |
|          | 1.4              |                    |                    |                    |                    |                          |                                     |                                     |                                     |
|          | 1.5              |                    |                    |                    |                    |                          |                                     |                                     |                                     |

$v_c$  = Schnittgeschwindigkeit · Cutting speed  
 $f_z$  = Vorschub pro Zahn · Feed per tooth

= sehr gut geeignet · very suitable  
 = gut geeignet · suitable

- Hochleistungswerkzeug
- Mit 3 Schneiden
- Schrappverzahnung
- Ungleiche Teilung
- Vibrationsarme Bearbeitung
- Konuswinkel 4°

- High performance tool
- With 3 flutes
- Roughing profile
- Variable spacing
- Low-vibration machining
- Taper angle 4°

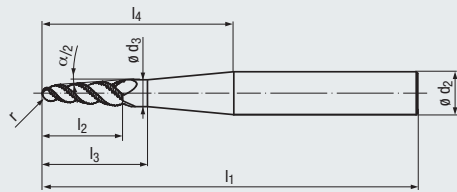
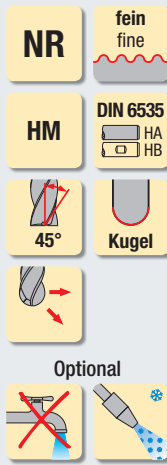

Allround

Beschichtung · Coating

ALCR

Einsatzgebiete – Material (siehe Seite 4)

Applications – material (see page 4)

- Speziell für schwer zerspanbare Werkstoffe geeignet
- In allen zähen Werkstoffen einsetzbar
- Optimiert zur Bearbeitung von Impellern und Integrated Bladed Rotors (IBR) aus Aluminium, Titan und Inconel

- Especially suitable for difficult to cut materials
- For all tough materials
- Optimised for machining Impellers and Integrated Bladed Rotors (IBR) made from aluminium, titanium and Inconel

|   |         |
|---|---------|
| P | 1.1-5.1 |
| M | 1.1-4.1 |
| N | 1.1-1.3 |
| S | 1.1-1.3 |
| S | 2.2-2.6 |

Bestell-Code · Order code

3546L

| $\alpha/2$ | r | l <sub>2</sub> | l <sub>3</sub> | l <sub>1</sub> | l <sub>4</sub> | $\varnothing d_3$ | $\varnothing d_2$<br>h6 | Z<br>(Flutes) | Dimens.-<br>Code |
|------------|---|----------------|----------------|----------------|----------------|-------------------|-------------------------|---------------|------------------|
| 4°         | 2 | 20             | 27             | 80             | 37,7           | 6,5               | 8                       | 3             | .04020C          |
|            | 2 | 25             | 32             | 95             | 52             | 7,2               | 10                      | 3             | .04020B          |
|            | 2 | 30             | 37             | 120            | 66             | 7,9               | 12                      | 3             | .04020A          |
|            | 3 | 35             | 42             | 140            | 81             | 10,6              | 16                      | 3             | .04030A          |
|            | 4 | 40             | 46             | 155            | 96             | 13                | 20                      | 3             | .04040A          |



**Präzisions-Spannhülsen-Aufnahmen FPC**

**High Precision Collet Holders FPC**

Die patentierten Präzisions-Spannhülsen-Aufnahmen FPC sind hochgenaue Werkzeug-Aufnahmen mit mechanischer Klemmung für höchste Spannkraft und Rundlaufgenauigkeit sowie mit sehr guten Dämpfungseigenschaften. Die Werkzeugspannung erfolgt mittels Spannhülsen.

The patented precision collet holders FPC are highly precise tool holders with mechanical clamping which provide superior clamping force and concentricity as well as excellent shock-absorbing properties. The tools are clamped via collets.

Das Spannen und Lösen des Werkzeugs geschieht mit einem Sechskantschlüssel, welcher seitlich den Spannmechanismus bedient – und das innerhalb weniger Sekunden. Es können alle Zylinderschäfte nach DIN 6535 oder DIN 1835 gespannt werden.

Tools are clamped and unclamped with a hexagon wrench which operates the clamping mechanism at the side – and in just a few seconds. All straight shanks according to DIN 6535 or DIN 1835 can be clamped.

Die Präzisions-Spannhülsen-Aufnahmen FPC eignen sich hervorragend zum Hochleistungs- und Hochgeschwindigkeitsfräsen. Darüber hinaus können diese auch zum Bohren, Reiben oder zur Gewindeherstellung eingesetzt werden.

The high-precision collet holders FPC are well suited for high-performance and high-speed milling. In addition they can be used for drilling, reaming and threading operations.



**Konische Hartmetall-Kugelfräser**  
Tapered solid carbide ball nose end mills

NR

Gültig für · Valid for  
3546L

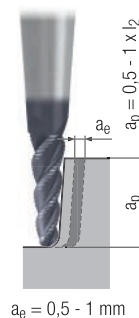
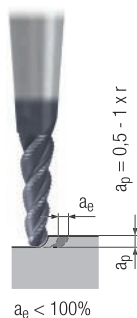

Für die Berechnung der Drehzahl n muss mit dem mittleren Durchmesser  $d_m$  (Messpunkt bei  $0,5 \times a_p$ ) gerechnet werden.

For the calculation of rpm (n), use the average diameter  $d_m$  (measuring point at  $0,5 \times a_p$ ).

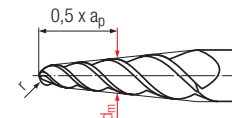

$$n = \frac{v_c \times 1000}{d_m \times \pi} \text{ [min}^{-1}\text{]}$$



|          | $v_c$<br>[m/min] | $f_z$<br>[mm] | $v_c$<br>[m/min] | $f_z$<br>[mm] |           |  |   |   |   |
|----------|------------------|---------------|------------------|---------------|-----------|--|---|---|---|
| <b>P</b> | 1.1              | 100           | 0,014 x r        | 120           | 0,018 x r |  | ■ | □ | ■ |
|          | 2.1              | 90            | 0,012 x r        | 110           | 0,016 x r |  | ■ | □ | ■ |
|          | 3.1              | 90            | 0,010 x r        | 100           | 0,014 x r |  | ■ | □ | ■ |
|          | 4.1              | 80            | 0,010 x r        | 100           | 0,012 x r |  | ■ | □ | ■ |
|          | 5.1              | 70            | 0,010 x r        | 90            | 0,012 x r |  | ■ | □ | ■ |
| <b>M</b> | 1.1              | 100           | 0,014 x r        | 120           | 0,018 x r |  |   |   | ■ |
|          | 2.1              | 100           | 0,013 x r        | 100           | 0,016 x r |  |   |   | ■ |
|          | 3.1              | 70            | 0,012 x r        | 70            | 0,014 x r |  |   |   | ■ |
|          | 4.1              | 70            | 0,010 x r        | 70            | 0,012 x r |  |   |   | ■ |
| <b>K</b> | 1.1              |               |                  |               |           |  |   |   |   |
|          | 1.2              |               |                  |               |           |  |   |   |   |
|          | 2.1              |               |                  |               |           |  |   |   |   |
|          | 2.2              |               |                  |               |           |  |   |   |   |
|          | 3.1              |               |                  |               |           |  |   |   |   |
|          | 3.2              |               |                  |               |           |  |   |   |   |
|          | 4.1              |               |                  |               |           |  |   |   |   |
| 4.2      |                  |               |                  |               |           |  |   |   |   |
| <b>N</b> | 1.1              | 280           | 0,020 x r        | 400           | 0,030 x r |  |   |   | ■ |
|          | 1.2              | 200           | 0,025 x r        | 280           | 0,030 x r |  |   |   | ■ |
|          | 1.3              | 140           | 0,030 x r        | 200           | 0,030 x r |  |   |   | ■ |
|          | 1.4              |               |                  |               |           |  |   |   |   |
|          | 1.5              |               |                  |               |           |  |   |   |   |
|          | 1.6              |               |                  |               |           |  |   |   |   |
|          | 2.1              |               |                  |               |           |  |   |   |   |
|          | 2.2              |               |                  |               |           |  |   |   |   |
|          | 2.3              |               |                  |               |           |  |   |   |   |
|          | 2.4              |               |                  |               |           |  |   |   |   |
|          | 2.5              |               |                  |               |           |  |   |   |   |
|          | 2.6              |               |                  |               |           |  |   |   |   |
|          | 2.7              |               |                  |               |           |  |   |   |   |
|          | 2.8              |               |                  |               |           |  |   |   |   |
|          | 3.1              |               |                  |               |           |  |   |   |   |
|          | 3.2              |               |                  |               |           |  |   |   |   |
| 4.1      |                  |               |                  |               |           |  |   |   |   |
| 4.2      |                  |               |                  |               |           |  |   |   |   |
| 4.3      |                  |               |                  |               |           |  |   |   |   |
| 4.4      |                  |               |                  |               |           |  |   |   |   |
| 5.1      |                  |               |                  |               |           |  |   |   |   |
| 5.2      |                  |               |                  |               |           |  |   |   |   |
| 5.3      |                  |               |                  |               |           |  |   |   |   |
| <b>S</b> | 1.1              | 90            | 0,015 x r        | 100           | 0,020 x r |  |   |   | ■ |
|          | 1.2              | 75            | 0,012 x r        | 80            | 0,017 x r |  |   |   | ■ |
|          | 1.3              | 45            | 0,010 x r        | 60            | 0,015 x r |  |   |   | ■ |
|          | 2.1              |               |                  |               |           |  |   |   |   |
|          | 2.2              | 25            | 0,010 x r        | 30            | 0,018 x r |  |   |   | ■ |
|          | 2.3              | 25            | 0,010 x r        | 30            | 0,016 x r |  |   |   | ■ |
|          | 2.4              | 25            | 0,010 x r        | 30            | 0,014 x r |  |   |   | ■ |
| 2.5      | 15               | 0,010 x r     | 20               | 0,012 x r     |           |  |   | ■ |   |
| 2.6      | 25               | 0,010 x r     | 30               | 0,012 x r     |           |  |   | ■ |   |
| <b>H</b> | 1.1              |               |                  |               |           |  |   |   |   |
|          | 1.2              |               |                  |               |           |  |   |   |   |
|          | 1.3              |               |                  |               |           |  |   |   |   |
|          | 1.4              |               |                  |               |           |  |   |   |   |
|          | 1.5              |               |                  |               |           |  |   |   |   |

$v_c$  = Schnittgeschwindigkeit · Cutting speed  
 $f_z$  = Vorschub pro Zahn · Feed per tooth

■ = sehr gut geeignet · very suitable  
□ = gut geeignet · suitable

- Multifunktionales Werkzeug
- Multi-functional tool
- Feine Schruppschicht-Verzahnung
- Fine semi-finishing profile
- Mit 2 Schneiden
- With 2 flutes
- Verschiedene Kegelwinkel
- Various taper angles
- Auch mit poliertem Spanraum erhältlich
- Also available with polished chip space

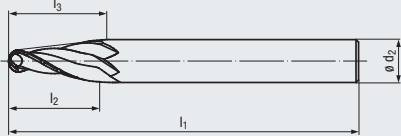
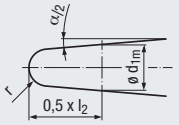

### Design I4:

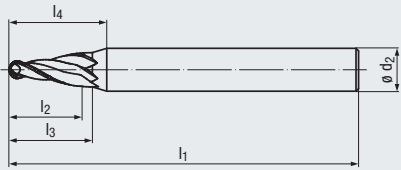

**NF** fein fine

**HM** DIN 6535 HA HB

**30°** Kugel

Optional

Mit poliertem Spanraum  
With polished chip space

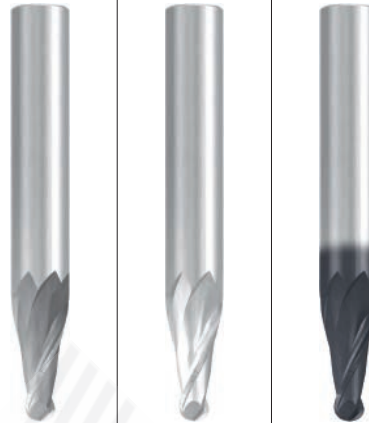

Allround

Allround

### Beschichtung · Coating

#### Einsatzgebiete – Material (siehe Seite 4)

- In fast allen Werkstoffen einsetzbar
- Zum Schruppen und Schlichten geeignet

#### Applications – material (see page 4)

- For almost all materials
- Suitable for roughing and finishing

### ALCR

|   |         |   |                  |         |
|---|---------|---|------------------|---------|
| N | 1.1-1.3 | P | 1.1-3.1          | 4.1-5.1 |
| N | 4.1-4.2 | M | 1.1-2.1          |         |
|   |         | K | 1.1-2.2          | 3.1-4.2 |
|   |         | N | 1.1-1.4          | 1.5     |
|   |         | N | 2.1-2.6          | 2.7-2.8 |
|   |         | N | 3.1-4.4, 5.2-5.3 |         |
|   |         | S | 1.1-1.2          | 1.3     |
|   |         | S | 2.1-2.2          | 2.3-2.6 |

### Bestell-Code · Order code

| $\alpha/2$ | r<br>±0,01 | l <sub>2</sub> | l <sub>3</sub> | l <sub>1</sub> | l <sub>4</sub> | d <sub>1m</sub> | ø d <sub>2</sub><br>h6 | Z<br>(Flutes) | Dimens.-<br>Code | 3446 | 3447 | 3446L |
|------------|------------|----------------|----------------|----------------|----------------|-----------------|------------------------|---------------|------------------|------|------|-------|
|            |            |                |                |                |                |                 |                        |               |                  |      |      |       |
| 3°         | 1,5        | 20             | 20             | 62             | 24             | 3,90            | 6                      | 2             | .03015A          | ●    | ●    | ●     |
|            | 2          | 31             | 31             | 80             | 35             | 5,42            | 8                      | 2             | .03020B          | ●    | ●    | ●     |
| 4°         | 0,5        | 20             | 20             | 62             | 24             | 2,33            | 6                      | 2             | .04005A          | ●    | ●    | ●     |
|            | 1          | 20             | 20             | 62             | 24             | 3,26            | 6                      | 2             | .04010A          | ●    | ●    | ●     |
|            | 1,5        | 20             | 20             | 63             | 25             | 4,20            | 8                      | 2             | .04015A          | ●    | ●    | ●     |
|            | 2          | 30             | 30             | 72             | –              | 5,83            | 8                      | 2             | .04020B          | ●    | ●    | ●     |
| 6°         | 0,5        | 20             | 24             | 62             | –              | 3,00            | 6                      | 2             | .06005A          | ●    | ●    | ●     |
|            | 1          | 19             | 19             | 62             | –              | 3,80            | 6                      | 2             | .06010A          | ●    | ●    | ●     |
|            | 1,5        | 15             | 15             | 62             | –              | 4,28            | 6                      | 2             | .06015A          | ●    | ●    | ●     |
|            | 1,5        | 25             | 25             | 68             | –              | 5,33            | 8                      | 2             | .06015B          | ●    | ●    | ●     |
|            | 2          | 20             | 20             | 68             | –              | 5,70            | 8                      | 2             | .06020A          | ●    | ●    | ●     |
|            | 2          | 30             | 30             | 80             | –              | 6,76            | 10                     | 2             | .06020B          | ●    | ●    | ●     |
| 8°         | 0,5        | 18             | 18             | 62             | –              | 3,40            | 6                      | 2             | .08005A          | ●    | ●    | ●     |
|            | 1          | 15             | 15             | 62             | –              | 3,85            | 6                      | 2             | .08010A          | ●    | ●    | ●     |
|            | 1,5        | 19             | 19             | 63             | –              | 5,28            | 8                      | 2             | .08015A          | ●    | ●    | ●     |
|            | 2          | 23             | 23             | 72             | –              | 6,71            | 10                     | 2             | .08020A          | ●    | ●    | ●     |

**Konische Hartmetall-Kugelfräser**  
Tapered solid carbide ball nose end mills

NF

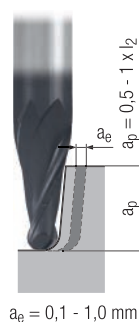
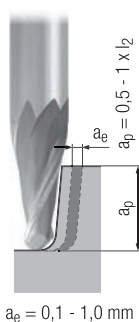
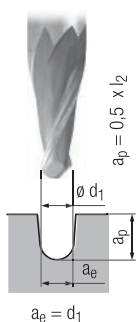

**Gültig für** · Valid for  
3446 3446L 3447

Für die Berechnung der Drehzahl n muss mit dem mittleren Durchmesser  $d_m$  (Messpunkt bei  $0,5 \times a_p$ ) gerechnet werden.

For the calculation of rpm (n), use the average diameter  $d_m$  (measuring point at  $0.5 \times a_p$ ).

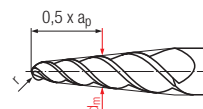

$$n = \frac{v_c \times 1000}{d_m \times \pi} \text{ [min}^{-1}\text{]}$$

Unbeschichtet · Uncoated

ALCR



|          | Unbeschichtet · Uncoated |               |                  |               | ALCR             |               |                                     |                                     |                                     |                                     |
|----------|--------------------------|---------------|------------------|---------------|------------------|---------------|-------------------------------------|-------------------------------------|-------------------------------------|-------------------------------------|
|          | $v_c$<br>[m/min]         | $f_z$<br>[mm] | $v_c$<br>[m/min] | $f_z$<br>[mm] | $v_c$<br>[m/min] | $f_z$<br>[mm] |                                     |                                     |                                     |                                     |
| <b>P</b> | 1.1                      |               |                  |               | 160              | 0,010 x r     | <input type="checkbox"/>            | <input checked="" type="checkbox"/> | <input type="checkbox"/>            | <input checked="" type="checkbox"/> |
|          | 2.1                      |               |                  |               | 140              | 0,010 x r     | <input type="checkbox"/>            | <input checked="" type="checkbox"/> | <input type="checkbox"/>            | <input checked="" type="checkbox"/> |
|          | 3.1                      |               |                  |               | 120              | 0,008 x r     | <input type="checkbox"/>            | <input checked="" type="checkbox"/> | <input type="checkbox"/>            | <input checked="" type="checkbox"/> |
|          | 4.1                      |               |                  |               | 100              | 0,008 x r     | <input type="checkbox"/>            | <input checked="" type="checkbox"/> | <input type="checkbox"/>            | <input checked="" type="checkbox"/> |
|          | 5.1                      |               |                  |               | 80               | 0,006 x r     | <input type="checkbox"/>            | <input checked="" type="checkbox"/> | <input type="checkbox"/>            | <input checked="" type="checkbox"/> |
| <b>M</b> | 1.1                      |               |                  |               | 80               | 0,006 x r     |                                     |                                     | <input type="checkbox"/>            | <input checked="" type="checkbox"/> |
|          | 2.1                      |               |                  |               | 70               | 0,006 x r     |                                     |                                     | <input type="checkbox"/>            | <input checked="" type="checkbox"/> |
|          | 3.1                      |               |                  |               |                  |               |                                     |                                     | <input type="checkbox"/>            | <input checked="" type="checkbox"/> |
|          | 4.1                      |               |                  |               |                  |               |                                     |                                     | <input type="checkbox"/>            | <input checked="" type="checkbox"/> |
| <b>K</b> | 1.1                      |               |                  |               | 160              | 0,010 x r     | <input checked="" type="checkbox"/> | <input checked="" type="checkbox"/> |                                     |                                     |
|          | 1.2                      |               |                  |               | 160              | 0,010 x r     | <input checked="" type="checkbox"/> | <input checked="" type="checkbox"/> |                                     |                                     |
|          | 2.1                      |               |                  |               | 140              | 0,008 x r     | <input checked="" type="checkbox"/> | <input checked="" type="checkbox"/> |                                     |                                     |
|          | 2.2                      |               |                  |               | 140              | 0,008 x r     | <input checked="" type="checkbox"/> | <input checked="" type="checkbox"/> |                                     |                                     |
|          | 3.1                      |               |                  |               | 120              | 0,008 x r     | <input checked="" type="checkbox"/> | <input checked="" type="checkbox"/> |                                     |                                     |
|          | 3.2                      |               |                  |               | 120              | 0,008 x r     | <input checked="" type="checkbox"/> | <input checked="" type="checkbox"/> |                                     |                                     |
|          | 4.1                      |               |                  |               | 100              | 0,006 x r     | <input checked="" type="checkbox"/> | <input checked="" type="checkbox"/> |                                     |                                     |
|          | 4.2                      |               |                  |               | 80               | 0,006 x r     | <input checked="" type="checkbox"/> | <input checked="" type="checkbox"/> |                                     |                                     |
| <b>N</b> | 1.1                      | 350           | 0,040 x r        | 300           | 0,020 x r        | 350           | 0,016 x r                           |                                     | <input type="checkbox"/>            | <input checked="" type="checkbox"/> |
|          | 1.2                      | 350           | 0,040 x r        | 300           | 0,020 x r        | 350           | 0,014 x r                           |                                     | <input type="checkbox"/>            | <input checked="" type="checkbox"/> |
|          | 1.3                      | 320           | 0,035 x r        | 270           | 0,017 x r        | 350           | 0,012 x r                           |                                     | <input type="checkbox"/>            | <input checked="" type="checkbox"/> |
|          | 1.4                      |               |                  |               |                  | 280           | 0,014 x r                           |                                     | <input type="checkbox"/>            | <input checked="" type="checkbox"/> |
|          | 1.5                      |               |                  |               |                  | 240           | 0,012 x r                           |                                     | <input type="checkbox"/>            | <input checked="" type="checkbox"/> |
|          | 1.6                      |               |                  |               |                  |               |                                     |                                     | <input type="checkbox"/>            | <input checked="" type="checkbox"/> |
|          | 2.1                      |               |                  |               |                  | 140           | 0,010 x r                           |                                     | <input type="checkbox"/>            | <input checked="" type="checkbox"/> |
|          | 2.2                      |               |                  |               |                  | 140           | 0,010 x r                           |                                     | <input type="checkbox"/>            | <input checked="" type="checkbox"/> |
|          | 2.3                      |               |                  |               |                  | 140           | 0,010 x r                           | <input type="checkbox"/>            | <input type="checkbox"/>            | <input checked="" type="checkbox"/> |
|          | 2.4                      |               |                  |               |                  | 120           | 0,008 x r                           | <input type="checkbox"/>            | <input type="checkbox"/>            | <input checked="" type="checkbox"/> |
|          | 2.5                      |               |                  |               |                  | 120           | 0,008 x r                           | <input type="checkbox"/>            | <input type="checkbox"/>            | <input checked="" type="checkbox"/> |
|          | 2.6                      |               |                  |               |                  | 120           | 0,008 x r                           | <input type="checkbox"/>            | <input type="checkbox"/>            | <input checked="" type="checkbox"/> |
|          | 2.7                      |               |                  |               |                  | 70            | 0,006 x r                           | <input type="checkbox"/>            | <input type="checkbox"/>            | <input checked="" type="checkbox"/> |
|          | 2.8                      |               |                  |               |                  | 70            | 0,006 x r                           | <input type="checkbox"/>            | <input type="checkbox"/>            | <input checked="" type="checkbox"/> |
|          | 3.1                      |               |                  |               |                  | 320           | 0,018 x r                           |                                     | <input type="checkbox"/>            | <input checked="" type="checkbox"/> |
|          | 3.2                      |               |                  |               |                  | 320           | 0,014 x r                           |                                     | <input type="checkbox"/>            | <input checked="" type="checkbox"/> |
| 4.1      |                          |               | 180              | 0,016 x r     | 240              | 0,016 x r     |                                     | <input type="checkbox"/>            | <input checked="" type="checkbox"/> |                                     |
| 4.2      |                          |               | 160              | 0,016 x r     | 350              | 0,016 x r     |                                     | <input type="checkbox"/>            | <input checked="" type="checkbox"/> |                                     |
| 4.3      |                          |               |                  |               | 180              | 0,012 x r     |                                     | <input type="checkbox"/>            | <input checked="" type="checkbox"/> |                                     |
| 4.4      |                          |               |                  |               | 90               | 0,012 x r     |                                     | <input type="checkbox"/>            | <input checked="" type="checkbox"/> |                                     |
| 5.1      |                          |               |                  |               |                  |               |                                     | <input type="checkbox"/>            | <input checked="" type="checkbox"/> |                                     |
| 5.2      |                          |               |                  |               | 80               | 0,006 x r     |                                     | <input type="checkbox"/>            | <input checked="" type="checkbox"/> |                                     |
| 5.3      |                          |               |                  |               | 160              | 0,012 x r     | <input type="checkbox"/>            | <input checked="" type="checkbox"/> | <input checked="" type="checkbox"/> |                                     |
| <b>S</b> | 1.1                      |               |                  |               | 80               | 0,008 x r     |                                     |                                     | <input type="checkbox"/>            | <input checked="" type="checkbox"/> |
|          | 1.2                      |               |                  |               | 60               | 0,006 x r     |                                     |                                     | <input type="checkbox"/>            | <input checked="" type="checkbox"/> |
|          | 1.3                      |               |                  |               | 40               | 0,006 x r     |                                     |                                     | <input type="checkbox"/>            | <input checked="" type="checkbox"/> |
|          | 2.1                      |               |                  |               | 50               | 0,006 x r     |                                     |                                     | <input type="checkbox"/>            | <input checked="" type="checkbox"/> |
|          | 2.2                      |               |                  |               | 20               | 0,004 x r     |                                     |                                     | <input type="checkbox"/>            | <input checked="" type="checkbox"/> |
|          | 2.3                      |               |                  |               | 20               | 0,004 x r     |                                     |                                     | <input type="checkbox"/>            | <input checked="" type="checkbox"/> |
|          | 2.4                      |               |                  |               | 20               | 0,004 x r     |                                     |                                     | <input type="checkbox"/>            | <input checked="" type="checkbox"/> |
| 2.5      |                          |               |                  | 15            | 0,004 x r        |               |                                     | <input type="checkbox"/>            | <input checked="" type="checkbox"/> |                                     |
| 2.6      |                          |               |                  | 20            | 0,004 x r        |               |                                     | <input type="checkbox"/>            | <input checked="" type="checkbox"/> |                                     |
| <b>H</b> | 1.1                      |               |                  |               |                  |               |                                     |                                     |                                     |                                     |
|          | 1.2                      |               |                  |               |                  |               |                                     |                                     |                                     |                                     |
|          | 1.3                      |               |                  |               |                  |               |                                     |                                     |                                     |                                     |
|          | 1.4                      |               |                  |               |                  |               |                                     |                                     |                                     |                                     |
|          | 1.5                      |               |                  |               |                  |               |                                     |                                     |                                     |                                     |

$v_c$  = Schnittgeschwindigkeit · Cutting speed  
 $f_z$  = Vorschub pro Zahn · Feed per tooth

= sehr gut geeignet · very suitable  
 = gut geeignet · suitable

- Multifunktionales Werkzeug
- Mit 2 Schneiden
- Verschiedene Kegelwinkel
- Auch mit poliertem Spanraum erhältlich

- Multi-functional tool
- With 2 flutes
- Various taper angles
- Also available with polished chip space

**N**

**HM**

DIN 6535

HA  
HB

30°

Kugel

Optional

Mit poliertem Spanraum  
With polished chip space

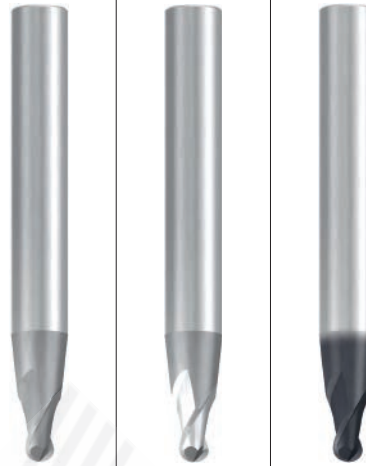

Allround

Allround

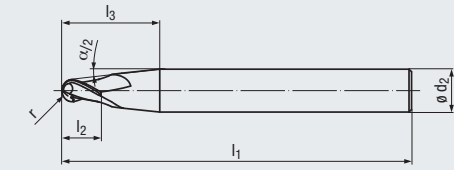

Design I<sub>4</sub>:

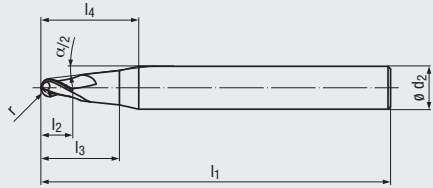

Beschichtung · Coating

Einsatzgebiete – Material (siehe Seite 4)

- In fast allen Werkstoffen einsetzbar
- Zum Schruppen und Schlichten geeignet

Applications – material (see page 4)

- For almost all materials
- Suitable for roughing and finishing

**ALCR**

N 1.1-1.3

N 4.1-4.2

P 1.1-3.1 4.1-5.1

M 1.1-2.1

K 1.1-2.2 3.1-4.2

N 1.1-1.4 1.5

N 2.1-2.6 2.7-2.8

N 3.1-4.4, 5.2-5.3

S 1.1-1.2 1.3

S 2.1-2.2 2.3-2.6

Bestell-Code · Order code

| $\alpha/2$ | r   | l <sub>2</sub> | l <sub>3</sub> | l <sub>1</sub> | l <sub>4</sub> | $\phi d_2$<br>h6 | Z<br>(Flutes) | Dimens.-<br>Code | 3442 | 3443 | 3442L |
|------------|-----|----------------|----------------|----------------|----------------|------------------|---------------|------------------|------|------|-------|
| 3°         | 1,5 | 4              | 24             | 63             | 26             | 8                | 2             | .03015A          | ●    | ●    | ●     |
|            | 3   | 7              | 38             | 80             | 39             | 10               | 2             | .03030A          | ●    | ●    | ●     |
| 4°         | 1,5 | 4              | 24             | 63             | 26             | 8                | 2             | .04015A          | ●    | ●    | ●     |
|            | 3   | 7              | 33             | 80             | —              | 10               | 2             | .04030A          | ●    | ●    | ●     |
| 6°         | 1,5 | 4              | 26             | 63             | —              | 8                | 2             | .06015A          | ●    | ●    | ●     |
|            | 3   | 7              | 23             | 80             | —              | 10               | 2             | .06030A          | ●    | ●    | ●     |
| 8°         | 1,5 | 4              | 27             | 80             | —              | 10               | 2             | .08015A          | ●    | ●    | ●     |
|            | 3   | 7              | 25             | 83             | —              | 12               | 2             | .08030A          | ●    | ●    | ●     |

**Konische Hartmetall-Kugelfräser**  
Tapered solid carbide ball nose end mills

**N**

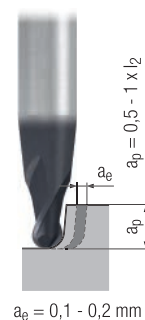
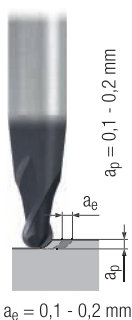
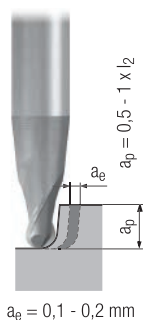
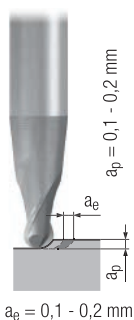

**Gültig für** · Valid for  
3442 3442L 3443

Für die Berechnung der Drehzahl  $n$  muss mit dem mittleren Durchmesser  $d_m$  (Messpunkt bei  $0,5 \times a_p$ ) gerechnet werden.

For the calculation of rpm ( $n$ ), use the average diameter  $d_m$  (measuring point at  $0,5 \times a_p$ ).

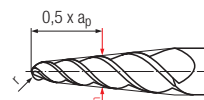

$$n = \frac{v_c \times 1000}{d_m \times \pi} \text{ [min}^{-1}\text{]}$$

Unbeschichtet · Uncoated

ALCR



|          | Unbeschichtet · Uncoated |               |                  |               | ALCR             |               |                  |               |                                     |                                     |                                     |                                     |
|----------|--------------------------|---------------|------------------|---------------|------------------|---------------|------------------|---------------|-------------------------------------|-------------------------------------|-------------------------------------|-------------------------------------|
|          | $v_c$<br>[m/min]         | $f_z$<br>[mm] | $v_c$<br>[m/min] | $f_z$<br>[mm] | $v_c$<br>[m/min] | $f_z$<br>[mm] | $v_c$<br>[m/min] | $f_z$<br>[mm] |                                     |                                     |                                     |                                     |
| <b>P</b> | 1.1                      |               |                  |               | 300              | 0,010 x r     | 160              | 0,010 x r     | <input type="checkbox"/>            | <input checked="" type="checkbox"/> | <input type="checkbox"/>            | <input checked="" type="checkbox"/> |
|          | 2.1                      |               |                  |               | 260              | 0,010 x r     | 140              | 0,010 x r     | <input type="checkbox"/>            | <input checked="" type="checkbox"/> | <input type="checkbox"/>            | <input checked="" type="checkbox"/> |
|          | 3.1                      |               |                  |               | 220              | 0,008 x r     | 120              | 0,008 x r     | <input type="checkbox"/>            | <input checked="" type="checkbox"/> | <input type="checkbox"/>            | <input checked="" type="checkbox"/> |
|          | 4.1                      |               |                  |               | 180              | 0,008 x r     | 100              | 0,008 x r     | <input type="checkbox"/>            | <input checked="" type="checkbox"/> | <input type="checkbox"/>            | <input checked="" type="checkbox"/> |
|          | 5.1                      |               |                  |               | 150              | 0,006 x r     | 80               | 0,006 x r     | <input type="checkbox"/>            | <input checked="" type="checkbox"/> | <input type="checkbox"/>            | <input checked="" type="checkbox"/> |
| <b>M</b> | 1.1                      |               |                  |               | 150              | 0,006 x r     | 80               | 0,006 x r     |                                     |                                     | <input type="checkbox"/>            | <input checked="" type="checkbox"/> |
|          | 2.1                      |               |                  |               | 120              | 0,006 x r     | 70               | 0,006 x r     |                                     |                                     | <input type="checkbox"/>            | <input checked="" type="checkbox"/> |
|          | 3.1                      |               |                  |               |                  |               |                  |               |                                     |                                     | <input type="checkbox"/>            | <input checked="" type="checkbox"/> |
|          | 4.1                      |               |                  |               |                  |               |                  |               |                                     |                                     | <input type="checkbox"/>            | <input checked="" type="checkbox"/> |
| <b>K</b> | 1.1                      |               |                  |               | 300              | 0,010 x r     | 160              | 0,010 x r     | <input checked="" type="checkbox"/> | <input checked="" type="checkbox"/> |                                     |                                     |
|          | 1.2                      |               |                  |               | 300              | 0,010 x r     | 160              | 0,010 x r     | <input checked="" type="checkbox"/> | <input checked="" type="checkbox"/> |                                     |                                     |
|          | 2.1                      |               |                  |               | 260              | 0,008 x r     | 140              | 0,008 x r     | <input checked="" type="checkbox"/> | <input checked="" type="checkbox"/> |                                     |                                     |
|          | 2.2                      |               |                  |               | 260              | 0,008 x r     | 140              | 0,008 x r     | <input checked="" type="checkbox"/> | <input checked="" type="checkbox"/> |                                     |                                     |
|          | 3.1                      |               |                  |               | 220              | 0,008 x r     | 120              | 0,008 x r     | <input checked="" type="checkbox"/> | <input checked="" type="checkbox"/> |                                     |                                     |
|          | 3.2                      |               |                  |               | 220              | 0,008 x r     | 120              | 0,008 x r     | <input checked="" type="checkbox"/> | <input checked="" type="checkbox"/> |                                     |                                     |
|          | 4.1                      |               |                  |               | 180              | 0,006 x r     | 100              | 0,006 x r     | <input checked="" type="checkbox"/> | <input checked="" type="checkbox"/> |                                     |                                     |
|          | 4.2                      |               |                  |               | 150              | 0,006 x r     | 80               | 0,006 x r     | <input checked="" type="checkbox"/> | <input checked="" type="checkbox"/> |                                     |                                     |
| <b>N</b> | 1.1                      | 490           | 0,016 x r        | 250           | 0,016 x r        | 700           | 0,016 x r        | 350           | 0,016 x r                           |                                     | <input type="checkbox"/>            | <input checked="" type="checkbox"/> |
|          | 1.2                      | 490           | 0,014 x r        | 250           | 0,014 x r        | 700           | 0,014 x r        | 350           | 0,014 x r                           |                                     | <input type="checkbox"/>            | <input checked="" type="checkbox"/> |
|          | 1.3                      | 490           | 0,012 x r        | 250           | 0,012 x r        | 700           | 0,012 x r        | 350           | 0,012 x r                           |                                     | <input type="checkbox"/>            | <input checked="" type="checkbox"/> |
|          | 1.4                      |               |                  |               |                  | 500           | 0,014 x r        | 280           | 0,014 x r                           |                                     | <input type="checkbox"/>            | <input checked="" type="checkbox"/> |
|          | 1.5                      |               |                  |               |                  | 450           | 0,012 x r        | 240           | 0,012 x r                           |                                     | <input type="checkbox"/>            | <input checked="" type="checkbox"/> |
|          | 1.6                      |               |                  |               |                  |               |                  |               |                                     |                                     | <input type="checkbox"/>            | <input checked="" type="checkbox"/> |
|          | 2.1                      |               |                  |               |                  | 260           | 0,010 x r        | 140           | 0,010 x r                           |                                     | <input type="checkbox"/>            | <input checked="" type="checkbox"/> |
|          | 2.2                      |               |                  |               |                  | 260           | 0,010 x r        | 140           | 0,010 x r                           |                                     | <input type="checkbox"/>            | <input checked="" type="checkbox"/> |
|          | 2.3                      |               |                  |               |                  | 260           | 0,010 x r        | 140           | 0,010 x r                           | <input type="checkbox"/>            | <input type="checkbox"/>            | <input checked="" type="checkbox"/> |
|          | 2.4                      |               |                  |               |                  | 220           | 0,008 x r        | 120           | 0,008 x r                           | <input type="checkbox"/>            | <input type="checkbox"/>            | <input checked="" type="checkbox"/> |
|          | 2.5                      |               |                  |               |                  | 220           | 0,008 x r        | 120           | 0,008 x r                           | <input type="checkbox"/>            | <input type="checkbox"/>            | <input checked="" type="checkbox"/> |
|          | 2.6                      |               |                  |               |                  | 220           | 0,008 x r        | 120           | 0,008 x r                           | <input type="checkbox"/>            | <input type="checkbox"/>            | <input checked="" type="checkbox"/> |
|          | 2.7                      |               |                  |               |                  | 140           | 0,006 x r        | 70            | 0,006 x r                           | <input type="checkbox"/>            | <input type="checkbox"/>            | <input checked="" type="checkbox"/> |
|          | 2.8                      |               |                  |               |                  | 140           | 0,006 x r        | 70            | 0,006 x r                           | <input type="checkbox"/>            | <input type="checkbox"/>            | <input checked="" type="checkbox"/> |
|          | 3.1                      |               |                  |               |                  | 600           | 0,018 x r        | 320           | 0,018 x r                           |                                     | <input type="checkbox"/>            | <input checked="" type="checkbox"/> |
|          | 3.2                      |               |                  |               |                  | 600           | 0,014 x r        | 320           | 0,014 x r                           |                                     | <input type="checkbox"/>            | <input checked="" type="checkbox"/> |
| 4.1      | 320                      | 0,016 x r     | 170              | 0,016 x r     | 460              | 0,016 x r     | 240              | 0,016 x r     |                                     | <input type="checkbox"/>            | <input checked="" type="checkbox"/> |                                     |
| 4.2      | 460                      | 0,016 x r     | 250              | 0,016 x r     | 650              | 0,016 x r     | 350              | 0,016 x r     |                                     | <input type="checkbox"/>            | <input checked="" type="checkbox"/> |                                     |
| 4.3      |                          |               |                  |               | 250              | 0,012 x r     | 180              | 0,012 x r     |                                     | <input type="checkbox"/>            | <input checked="" type="checkbox"/> |                                     |
| 4.4      |                          |               |                  |               | 180              | 0,012 x r     | 90               | 0,012 x r     |                                     | <input type="checkbox"/>            | <input checked="" type="checkbox"/> |                                     |
| 5.1      |                          |               |                  |               |                  |               |                  |               |                                     | <input type="checkbox"/>            | <input checked="" type="checkbox"/> |                                     |
| 5.2      |                          |               |                  |               | 180              | 0,006 x r     | 80               | 0,006 x r     |                                     | <input type="checkbox"/>            | <input checked="" type="checkbox"/> |                                     |
| 5.3      |                          |               |                  |               | 300              | 0,012 x r     | 160              | 0,012 x r     | <input type="checkbox"/>            | <input checked="" type="checkbox"/> | <input checked="" type="checkbox"/> |                                     |
| <b>S</b> | 1.1                      |               |                  |               | 150              | 0,008 x r     | 80               | 0,008 x r     |                                     | <input type="checkbox"/>            | <input checked="" type="checkbox"/> |                                     |
|          | 1.2                      |               |                  |               | 120              | 0,006 x r     | 60               | 0,006 x r     |                                     | <input type="checkbox"/>            | <input checked="" type="checkbox"/> |                                     |
|          | 1.3                      |               |                  |               | 70               | 0,006 x r     | 40               | 0,006 x r     |                                     | <input type="checkbox"/>            | <input checked="" type="checkbox"/> |                                     |
|          | 2.1                      |               |                  |               | 110              | 0,006 x r     | 50               | 0,006 x r     |                                     | <input type="checkbox"/>            | <input checked="" type="checkbox"/> |                                     |
|          | 2.2                      |               |                  |               | 30               | 0,004 x r     | 20               | 0,004 x r     |                                     | <input type="checkbox"/>            | <input checked="" type="checkbox"/> |                                     |
|          | 2.3                      |               |                  |               | 30               | 0,004 x r     | 20               | 0,004 x r     |                                     | <input type="checkbox"/>            | <input checked="" type="checkbox"/> |                                     |
|          | 2.4                      |               |                  |               | 30               | 0,004 x r     | 20               | 0,004 x r     |                                     | <input type="checkbox"/>            | <input checked="" type="checkbox"/> |                                     |
| 2.5      |                          |               |                  | 20            | 0,004 x r        | 15            | 0,004 x r        |               | <input type="checkbox"/>            | <input checked="" type="checkbox"/> |                                     |                                     |
| 2.6      |                          |               |                  | 30            | 0,004 x r        | 20            | 0,004 x r        |               | <input type="checkbox"/>            | <input checked="" type="checkbox"/> |                                     |                                     |
| <b>H</b> | 1.1                      |               |                  |               |                  |               |                  |               |                                     |                                     |                                     |                                     |
|          | 1.2                      |               |                  |               |                  |               |                  |               |                                     |                                     |                                     |                                     |
|          | 1.3                      |               |                  |               |                  |               |                  |               |                                     |                                     |                                     |                                     |
|          | 1.4                      |               |                  |               |                  |               |                  |               |                                     |                                     |                                     |                                     |
|          | 1.5                      |               |                  |               |                  |               |                  |               |                                     |                                     |                                     |                                     |

$v_c$  = Schnittgeschwindigkeit · Cutting speed  
 $f_z$  = Vorschub pro Zahn · Feed per tooth

= sehr gut geeignet · very suitable  
 = gut geeignet · suitable

- Multifunktionales Werkzeug
- Mit 3 Schneiden
- Verschiedene Kegelwinkel
- Auch mit poliertem Spanraum erhältlich
- Multi-functional tool
- With 3 flutes
- Various taper angles
- Also available with polished chip space

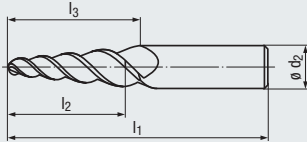
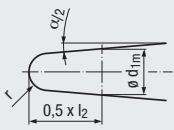

Design I<sub>4</sub>:

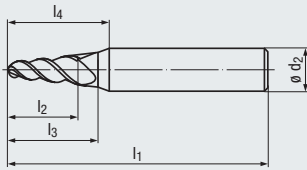

**N**

**HM** **DIN 6535**  
HA  
HB

**45°** **Kugel**

**Optional**

Mit poliertem Spanraum  
With polished chip space

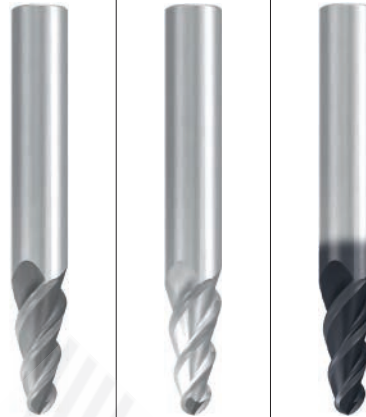

Allround

Allround

Beschichtung · Coating

Einsatzgebiete – Material (siehe Seite 4)

- In fast allen Werkstoffen einsetzbar
- Zum Schlichten geeignet

Applications – material (see page 4)

- For almost all materials
- Suitable for finishing

**ALCR**

- N 1.1-1.3
- N 4.1-4.2

- P 1.1-3.1 4.1-5.1
- M 1.1-2.1
- K 1.1-2.2 3.1-4.2
- N 1.1-1.4 1.5
- N 2.1-2.6 2.7-2.8
- N 3.1-4.4, 5.2-5.3
- S 1.1-1.2 1.3
- S 2.1-2.2 2.3-2.6

| Bestell-Code · Order code |                            |                |                |                |                |                 |                             |               |                  | 3440 | 3441 | 3440L |
|---------------------------|----------------------------|----------------|----------------|----------------|----------------|-----------------|-----------------------------|---------------|------------------|------|------|-------|
| $\alpha/2$                | r<br><small>±0,005</small> | l <sub>2</sub> | l <sub>3</sub> | l <sub>1</sub> | l <sub>4</sub> | d <sub>1m</sub> | $\phi$ d <sub>2</sub><br>h6 | Z<br>(Flutes) | Dimens.-<br>Code |      |      |       |
| 3°                        | 1,5                        | 20             | 20             | 62             | 24             | 3,90            | 6                           | 3             | .03015A          | ●    | ●    | ●     |
|                           | 2                          | 21             | 21             | 66             | —              | 4,90            | 6                           | 3             | .03020A          | ●    | ●    | ●     |
|                           | 2                          | 31             | 31             | 80             | 35             | 5,42            | 8                           | 3             | .03020B          | ●    | ●    | ●     |
|                           | 3                          | 22             | 22             | 72             | —              | 6,85            | 8                           | 3             | .03030A          | ●    | ●    | ●     |
|                           | 3                          | 31             | 31             | 80             | 35             | 7,32            | 10                          | 3             | .03030B          | ●    | ●    | ●     |
| 4°                        | 0,5                        | 20             | 20             | 62             | 24             | 2,33            | 6                           | 3             | .04005A          | ●    | ●    | ●     |
|                           | 1                          | 20             | 20             | 62             | 24             | 3,26            | 6                           | 3             | .04010A          | ●    | ●    | ●     |
|                           | 1,5                        | 20             | 20             | 63             | 25             | 4,20            | 8                           | 3             | .04015A          | ●    | ●    | ●     |
|                           | 2                          | 20             | 30             | 68             | —              | 5,13            | 8                           | 3             | .04020A          | ●    | ●    | ●     |
|                           | 2                          | 30             | 30             | 72             | —              | 5,83            | 8                           | 3             | .04020B          | ●    | ●    | ●     |
|                           | 3                          | 25             | 31             | 72             | —              | 7,34            | 10                          | 3             | .04030A          | ●    | ●    | ●     |
| 6°                        | 3                          | 31             | 31             | 80             | —              | 7,76            | 10                          | 3             | .04030B          | ●    | ●    | ●     |
|                           | 0,5                        | 20             | 24             | 62             | —              | 3,00            | 6                           | 3             | .06005A          | ●    | ●    | ●     |
|                           | 1                          | 19             | 19             | 62             | —              | 3,80            | 6                           | 3             | .06010A          | ●    | ●    | ●     |
|                           | 1                          | 29             | 29             | 72             | —              | 4,85            | 8                           | 3             | .06010B          | ●    | ●    | ●     |
|                           | 1,5                        | 15             | 15             | 62             | —              | 4,28            | 6                           | 3             | .06015A          | ●    | ●    | ●     |
|                           | 1,5                        | 25             | 25             | 68             | —              | 5,33            | 8                           | 3             | .06015B          | ●    | ●    | ●     |
|                           | 2                          | 20             | 20             | 68             | —              | 5,70            | 8                           | 3             | .06020A          | ●    | ●    | ●     |
|                           | 2                          | 30             | 30             | 80             | —              | 6,76            | 10                          | 3             | .06020B          | ●    | ●    | ●     |
| 8°                        | 3                          | 21             | 21             | 72             | —              | 7,61            | 10                          | 3             | .06030A          | ●    | ●    | ●     |
|                           | 3                          | 31             | 31             | 83             | —              | 8,66            | 12                          | 3             | .06030B          | ●    | ●    | ●     |
|                           | 0,5                        | 18             | 18             | 62             | —              | 3,40            | 6                           | 3             | .08005A          | ●    | ●    | ●     |
|                           | 1                          | 15             | 15             | 62             | —              | 3,85            | 6                           | 3             | .08010A          | ●    | ●    | ●     |
|                           | 1                          | 22             | 22             | 63             | —              | 4,83            | 8                           | 3             | .08010B          | ●    | ●    | ●     |
| 17,5°                     | 1,5                        | 19             | 19             | 63             | —              | 5,28            | 8                           | 3             | .08015A          | ●    | ●    | ●     |
|                           | 1,5                        | 26             | 26             | 72             | —              | 6,26            | 10                          | 3             | .08015B          | ●    | ●    | ●     |
|                           | 2                          | 23             | 23             | 72             | —              | 6,71            | 10                          | 3             | .08020A          | ●    | ●    | ●     |
| 17,5°                     | 0,5                        | 8              | 8              | 57             | —              | 3,26            | 6                           | 3             | .17505A          | ●    | ●    | ●     |

**Konische Hartmetall-Kugelfräser**  
Tapered solid carbide ball nose end mills

**N**

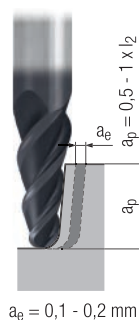
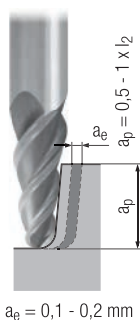

**Gültig für** · Valid for  
3440 3440L 3441

Für die Berechnung der Drehzahl n muss mit dem mittleren Durchmesser  $d_m$  (Messpunkt bei  $0,5 \times a_p$ ) gerechnet werden.

For the calculation of rpm (n), use the average diameter  $d_m$  (measuring point at  $0,5 \times a_p$ ).

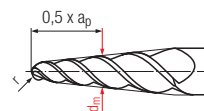

$$n = \frac{v_c \times 1000}{d_m \times \pi} \text{ [min}^{-1}\text{]}$$

Unbeschichtet · Uncoated

ALCR



|          | Unbeschichtet · Uncoated |               | ALCR             |               |                                     |                                     |                          |                                     |                                     |
|----------|--------------------------|---------------|------------------|---------------|-------------------------------------|-------------------------------------|--------------------------|-------------------------------------|-------------------------------------|
|          | $v_c$<br>[m/min]         | $f_z$<br>[mm] | $v_c$<br>[m/min] | $f_z$<br>[mm] |                                     |                                     |                          |                                     |                                     |
| <b>P</b> | 1.1                      |               | 120              | 0,010 x r     | <input type="checkbox"/>            | <input checked="" type="checkbox"/> | <input type="checkbox"/> | <input checked="" type="checkbox"/> |                                     |
|          | 2.1                      |               | 100              | 0,010 x r     | <input type="checkbox"/>            | <input checked="" type="checkbox"/> | <input type="checkbox"/> | <input checked="" type="checkbox"/> |                                     |
|          | 3.1                      |               | 90               | 0,008 x r     | <input type="checkbox"/>            | <input checked="" type="checkbox"/> | <input type="checkbox"/> | <input checked="" type="checkbox"/> |                                     |
|          | 4.1                      |               | 70               | 0,008 x r     | <input type="checkbox"/>            | <input checked="" type="checkbox"/> | <input type="checkbox"/> | <input checked="" type="checkbox"/> |                                     |
|          | 5.1                      |               | 60               | 0,006 x r     | <input type="checkbox"/>            | <input checked="" type="checkbox"/> | <input type="checkbox"/> | <input checked="" type="checkbox"/> |                                     |
| <b>M</b> | 1.1                      |               | 60               | 0,006 x r     |                                     |                                     | <input type="checkbox"/> | <input checked="" type="checkbox"/> |                                     |
|          | 2.1                      |               | 50               | 0,006 x r     |                                     |                                     | <input type="checkbox"/> | <input checked="" type="checkbox"/> |                                     |
|          | 3.1                      |               |                  |               |                                     |                                     | <input type="checkbox"/> | <input checked="" type="checkbox"/> |                                     |
|          | 4.1                      |               |                  |               |                                     |                                     | <input type="checkbox"/> | <input checked="" type="checkbox"/> |                                     |
| <b>K</b> | 1.1                      |               | 120              | 0,010 x r     | <input checked="" type="checkbox"/> | <input checked="" type="checkbox"/> |                          |                                     |                                     |
|          | 1.2                      |               | 120              | 0,010 x r     | <input checked="" type="checkbox"/> | <input checked="" type="checkbox"/> |                          |                                     |                                     |
|          | 2.1                      |               | 100              | 0,008 x r     | <input checked="" type="checkbox"/> | <input checked="" type="checkbox"/> |                          |                                     |                                     |
|          | 2.2                      |               | 100              | 0,008 x r     | <input checked="" type="checkbox"/> | <input checked="" type="checkbox"/> |                          |                                     |                                     |
|          | 3.1                      |               | 90               | 0,008 x r     | <input checked="" type="checkbox"/> | <input checked="" type="checkbox"/> |                          |                                     |                                     |
|          | 3.2                      |               | 90               | 0,008 x r     | <input checked="" type="checkbox"/> | <input checked="" type="checkbox"/> |                          |                                     |                                     |
|          | 4.1                      |               | 70               | 0,006 x r     | <input checked="" type="checkbox"/> | <input checked="" type="checkbox"/> |                          |                                     |                                     |
|          | 4.2                      |               | 60               | 0,006 x r     | <input checked="" type="checkbox"/> | <input checked="" type="checkbox"/> |                          |                                     |                                     |
| <b>N</b> | 1.1                      | 180           | 0,016 x r        | 260           | 0,016 x r                           |                                     |                          | <input type="checkbox"/>            | <input checked="" type="checkbox"/> |
|          | 1.2                      | 180           | 0,014 x r        | 260           | 0,014 x r                           |                                     |                          | <input type="checkbox"/>            | <input checked="" type="checkbox"/> |
|          | 1.3                      | 180           | 0,012 x r        | 260           | 0,012 x r                           |                                     |                          | <input type="checkbox"/>            | <input checked="" type="checkbox"/> |
|          | 1.4                      |               |                  | 200           | 0,014 x r                           |                                     |                          | <input type="checkbox"/>            | <input checked="" type="checkbox"/> |
|          | 1.5                      |               |                  | 180           | 0,012 x r                           |                                     |                          | <input type="checkbox"/>            | <input checked="" type="checkbox"/> |
|          | 1.6                      |               |                  |               |                                     |                                     |                          | <input type="checkbox"/>            | <input checked="" type="checkbox"/> |
|          | 2.1                      |               |                  | 100           | 0,010 x r                           |                                     |                          | <input type="checkbox"/>            | <input checked="" type="checkbox"/> |
|          | 2.2                      |               |                  | 100           | 0,010 x r                           |                                     |                          | <input type="checkbox"/>            | <input checked="" type="checkbox"/> |
|          | 2.3                      |               |                  | 100           | 0,010 x r                           | <input type="checkbox"/>            | <input type="checkbox"/> | <input type="checkbox"/>            | <input checked="" type="checkbox"/> |
|          | 2.4                      |               |                  | 80            | 0,008 x r                           |                                     |                          | <input type="checkbox"/>            | <input checked="" type="checkbox"/> |
|          | 2.5                      |               |                  | 80            | 0,008 x r                           |                                     |                          | <input type="checkbox"/>            | <input checked="" type="checkbox"/> |
|          | 2.6                      |               |                  | 80            | 0,008 x r                           | <input type="checkbox"/>            | <input type="checkbox"/> | <input type="checkbox"/>            | <input checked="" type="checkbox"/> |
|          | 2.7                      |               |                  | 50            | 0,006 x r                           |                                     |                          | <input type="checkbox"/>            | <input checked="" type="checkbox"/> |
|          | 2.8                      |               |                  | 50            | 0,006 x r                           |                                     |                          | <input type="checkbox"/>            | <input checked="" type="checkbox"/> |
|          | 3.1                      |               |                  | 240           | 0,018 x r                           |                                     |                          | <input type="checkbox"/>            | <input checked="" type="checkbox"/> |
|          | 3.2                      |               |                  | 240           | 0,014 x r                           |                                     |                          | <input type="checkbox"/>            | <input checked="" type="checkbox"/> |
| 4.1      | 130                      | 0,016 x r     | 180              | 0,016 x r     |                                     |                                     | <input type="checkbox"/> | <input checked="" type="checkbox"/> |                                     |
| 4.2      |                          |               | 160              | 0,016 x r     |                                     |                                     | <input type="checkbox"/> | <input checked="" type="checkbox"/> |                                     |
| 4.3      | 110                      | 0,016 x r     | 100              | 0,012 x r     |                                     |                                     | <input type="checkbox"/> | <input checked="" type="checkbox"/> |                                     |
| 4.4      |                          |               | 70               | 0,012 x r     |                                     |                                     | <input type="checkbox"/> | <input checked="" type="checkbox"/> |                                     |
| 5.1      |                          |               |                  |               |                                     |                                     | <input type="checkbox"/> | <input checked="" type="checkbox"/> |                                     |
| 5.2      |                          |               | 60               | 0,006 x r     |                                     |                                     | <input type="checkbox"/> | <input checked="" type="checkbox"/> |                                     |
| 5.3      |                          |               | 120              | 0,012 x r     | <input type="checkbox"/>            | <input checked="" type="checkbox"/> |                          | <input checked="" type="checkbox"/> |                                     |
| <b>S</b> | 1.1                      |               | 60               | 0,008 x r     |                                     |                                     | <input type="checkbox"/> | <input checked="" type="checkbox"/> |                                     |
|          | 1.2                      |               | 50               | 0,006 x r     |                                     |                                     | <input type="checkbox"/> | <input checked="" type="checkbox"/> |                                     |
|          | 1.3                      |               | 30               | 0,006 x r     |                                     |                                     | <input type="checkbox"/> | <input checked="" type="checkbox"/> |                                     |
|          | 2.1                      |               |                  | 40            | 0,006 x r                           |                                     |                          | <input type="checkbox"/>            | <input checked="" type="checkbox"/> |
|          | 2.2                      |               |                  | 15            | 0,004 x r                           |                                     |                          | <input type="checkbox"/>            | <input checked="" type="checkbox"/> |
|          | 2.3                      |               |                  | 15            | 0,004 x r                           |                                     |                          | <input type="checkbox"/>            | <input checked="" type="checkbox"/> |
|          | 2.4                      |               |                  | 15            | 0,004 x r                           |                                     |                          | <input type="checkbox"/>            | <input checked="" type="checkbox"/> |
| 2.5      |                          |               | 10               | 0,004 x r     |                                     |                                     | <input type="checkbox"/> | <input checked="" type="checkbox"/> |                                     |
| 2.6      |                          |               | 15               | 0,004 x r     |                                     |                                     | <input type="checkbox"/> | <input checked="" type="checkbox"/> |                                     |
| <b>H</b> | 1.1                      |               |                  |               |                                     |                                     |                          |                                     |                                     |
|          | 1.2                      |               |                  |               |                                     |                                     |                          |                                     |                                     |
|          | 1.3                      |               |                  |               |                                     |                                     |                          |                                     |                                     |
|          | 1.4                      |               |                  |               |                                     |                                     |                          |                                     |                                     |
|          | 1.5                      |               |                  |               |                                     |                                     |                          |                                     |                                     |

$v_c$  = Schnittgeschwindigkeit · Cutting speed  
 $f_z$  = Vorschub pro Zahn · Feed per tooth

= sehr gut geeignet · very suitable  
 = gut geeignet · suitable

- Hochleistungswerkzeug
- Mit 3 Schneiden
- Schlichtgeometrie

- High performance tool
- With 3 flutes
- Finishing geometry

**N**

**HM**

**DIN 6535**  
HA  
HB



34/35/36°



Kugel



Optional



Allround

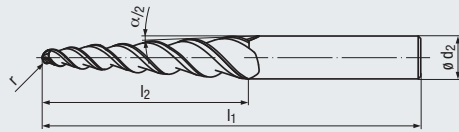

Beschichtung · Coating

**ALCR**

Einsatzgebiete – Material (siehe Seite 4)

Applications – material (see page 4)

- Speziell für schwer zerspanbare Werkstoffe geeignet
- In allen zähen Werkstoffen einsetzbar

- Especially suitable for difficult to cut materials
- For all tough materials

- P** 1.1-5.1
- M** 1.1-4.1
- N** 1.3-1.5
- S** 1.1-1.3
- S** 2.2-2.6

Bestell-Code · Order code

**3550L**

| $\alpha/2$ | r<br>$\pm 0,01$ | $l_2$ | $l_1$ | $\phi d_2$<br>h6 | Z<br>(Flutes) | Dimens.-<br>Code |   |  |  |
|------------|-----------------|-------|-------|------------------|---------------|------------------|---|--|--|
| 4°         | 2               | 59    | 120   | 12               | 3             | .04020A          | ● |  |  |
|            | 2               | 87    | 150   | 16               | 3             | .04020B          | ● |  |  |
|            | 3               | 74    | 140   | 16               | 3             | .04030A          | ● |  |  |
|            | 3               | 103   | 165   | 20               | 3             | .04030B          | ● |  |  |
|            | 4               | 89    | 155   | 20               | 3             | .04040A          | ● |  |  |



Sie haben Fragen zu einem unserer Produkte?  
Sprechen Sie doch einfach den für Sie zuständigen  
EMUGE-FRANKEN Vertriebspartner an.

[www.emuge-franken.com/vertrieb](http://www.emuge-franken.com/vertrieb)

Do you have questions about one of our products?  
Just ask your EMUGE-FRANKEN sales contact.

[www.emuge-franken.com/sales](http://www.emuge-franken.com/sales)



**Konische Hartmetall-Kugelfräser**  
Tapered solid carbide ball nose end mills

**N**



$a_e = 0,5 - 1 \text{ mm}$

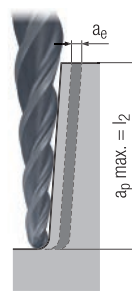

$a_e = 0,1 - 0,2 \text{ mm}$

**Gültig für** · Valid for  
3550L

Für die Berechnung der Drehzahl  $n$  muss mit dem mittleren Durchmesser  $d_m$  (Messpunkt bei  $0,5 \times a_p$ ) gerechnet werden.

For the calculation of rpm ( $n$ ), use the average diameter  $d_m$  (measuring point at  $0,5 \times a_p$ ).

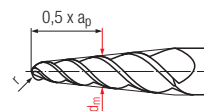

$$n = \frac{v_c \times 1000}{d_m \times \pi} \text{ [min}^{-1}\text{]}$$

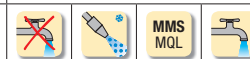

|          | $v_c$<br>[m/min] | $f_z$<br>[mm] | $v_c$<br>[m/min] | $f_z$<br>[mm] |      |   |   |   |
|----------|------------------|---------------|------------------|---------------|------|---|---|---|
| <b>P</b> | 1.1              | 120           | 0,07             | 80            | 0,05 | ■ | □ | ■ |
|          | 2.1              | 110           | 0,06             | 70            | 0,05 | ■ | □ | ■ |
|          | 3.1              | 100           | 0,05             | 60            | 0,04 | ■ | □ | ■ |
|          | 4.1              | 90            | 0,04             | 60            | 0,04 | ■ |   |   |
|          | 5.1              | 80            | 0,04             | 50            | 0,03 | ■ |   |   |
| <b>M</b> | 1.1              | 90            | 0,07             | 60            | 0,03 |   |   | ■ |
|          | 2.1              | 90            | 0,07             | 60            | 0,03 |   |   | ■ |
|          | 3.1              | 70            | 0,07             | 50            | 0,03 |   |   | ■ |
|          | 4.1              | 70            | 0,07             | 50            | 0,03 |   |   | ■ |
| <b>K</b> | 1.1              |               |                  |               |      |   |   |   |
|          | 1.2              |               |                  |               |      |   |   |   |
|          | 2.1              |               |                  |               |      |   |   |   |
|          | 2.2              |               |                  |               |      |   |   |   |
|          | 3.1              |               |                  |               |      |   |   |   |
|          | 3.2              |               |                  |               |      |   |   |   |
|          | 4.1              |               |                  |               |      |   |   |   |
| <b>N</b> | 1.1              |               |                  |               |      |   |   |   |
|          | 1.2              |               |                  |               |      |   |   |   |
|          | 1.3              | 280           | 0,12             | 200           | 0,06 |   |   | ■ |
|          | 1.4              | 200           | 0,12             | 140           | 0,06 |   |   | ■ |
|          | 1.5              | 140           | 0,12             | 100           | 0,06 |   |   | ■ |
|          | 1.6              |               |                  |               |      |   |   |   |
|          | 2.1              |               |                  |               |      |   |   |   |
|          | 2.2              |               |                  |               |      |   |   |   |
|          | 2.3              |               |                  |               |      |   |   |   |
|          | 2.4              |               |                  |               |      |   |   |   |
|          | 2.5              |               |                  |               |      |   |   |   |
|          | 2.6              |               |                  |               |      |   |   |   |
|          | 2.7              |               |                  |               |      |   |   |   |
|          | 2.8              |               |                  |               |      |   |   |   |
|          | 3.1              |               |                  |               |      |   |   |   |
|          | 3.2              |               |                  |               |      |   |   |   |
| 4.1      |                  |               |                  |               |      |   |   |   |
| 4.2      |                  |               |                  |               |      |   |   |   |
| 4.3      |                  |               |                  |               |      |   |   |   |
| 4.4      |                  |               |                  |               |      |   |   |   |
| 5.1      |                  |               |                  |               |      |   |   |   |
| 5.2      |                  |               |                  |               |      |   |   |   |
| 5.3      |                  |               |                  |               |      |   |   |   |
| <b>S</b> | 1.1              | 90            | 0,07             | 60            | 0,03 |   |   | ■ |
|          | 1.2              | 75            | 0,07             | 50            | 0,03 |   |   | ■ |
|          | 1.3              | 45            | 0,07             | 30            | 0,03 |   |   | ■ |
|          | 2.1              |               |                  |               |      |   |   |   |
|          | 2.2              | 25            | 0,07             | 15            | 0,03 |   |   | ■ |
|          | 2.3              | 25            | 0,07             | 15            | 0,03 |   |   | ■ |
|          | 2.4              | 25            | 0,07             | 15            | 0,03 |   |   | ■ |
| 2.5      | 15               | 0,07          | 10               | 0,03          |      |   | ■ |   |
| 2.6      | 25               | 0,07          | 15               | 0,03          |      |   | ■ |   |
| <b>H</b> | 1.1              |               |                  |               |      |   |   |   |
|          | 1.2              |               |                  |               |      |   |   |   |
|          | 1.3              |               |                  |               |      |   |   |   |
|          | 1.4              |               |                  |               |      |   |   |   |
|          | 1.5              |               |                  |               |      |   |   |   |

$v_c$  = Schnittgeschwindigkeit · Cutting speed  
 $f_z$  = Vorschub pro Zahn · Feed per tooth

■ = sehr gut geeignet · very suitable  
□ = gut geeignet · suitable

- Hochleistungswerkzeug
- Mit 3 Schneiden im Radius
- 6 Umfangsschneiden

- High performance tool
- 3 flutes in the ball nose section
- 6 radial flutes

**N**

**HM** **DIN 6535**  
HA  
HB

**38°** **Kugel**

**Optional**



Allround

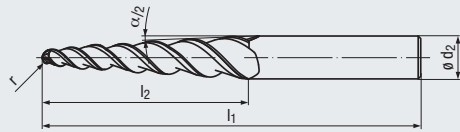

Beschichtung · Coating

**ALCR**

Einsatzgebiete – Material (siehe Seite 4)

Applications – material (see page 4)

- Speziell für schwer zerspanbare Werkstoffe geeignet
- In allen zähen Werkstoffen einsetzbar

- Especially suitable for difficult to cut materials
- For all tough materials

- P** 1.1-5.1
- M** 1.1-4.1
- N** 1.3-1.5
- S** 1.1-1.3
- S** 2.2-2.6

Bestell-Code · Order code

3548L

| $\alpha/2$ | r<br>$\pm 0,01$ | $l_2$ | $l_1$ | $\phi d_2$<br>h6 | Z<br>(Flutes) | Dimens.-<br>Code |   |  |  |
|------------|-----------------|-------|-------|------------------|---------------|------------------|---|--|--|
| 4°         | 2               | 59    | 120   | 12               | 3/6           | .04020A          | ● |  |  |
|            | 2               | 87    | 150   | 16               | 3/6           | .04020B          | ● |  |  |
|            | 3               | 74    | 140   | 16               | 3/6           | .04030A          | ● |  |  |
|            | 3               | 103   | 165   | 20               | 3/6           | .04030B          | ● |  |  |
|            | 4               | 89    | 155   | 20               | 3/6           | .04040A          | ● |  |  |

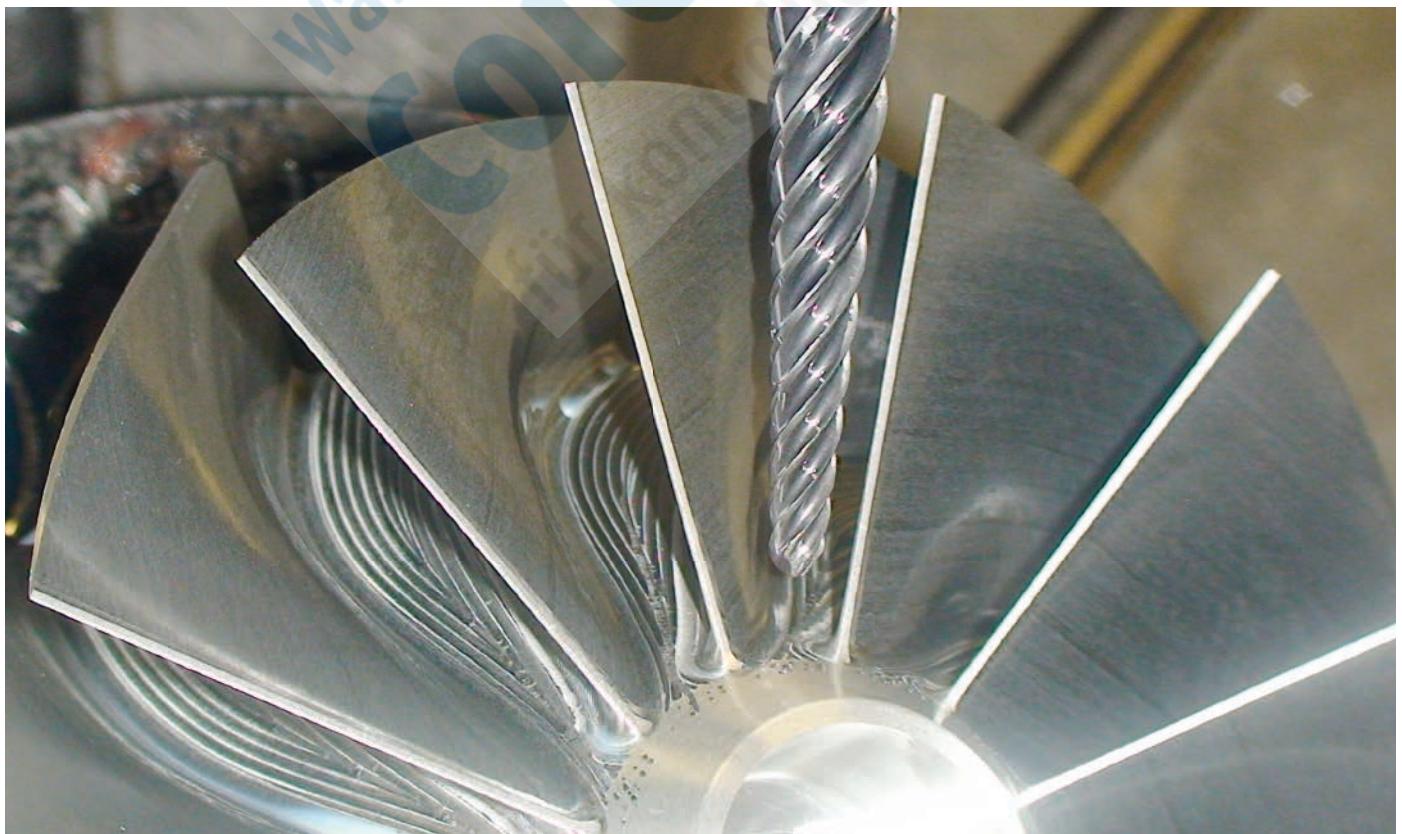

**Konische Hartmetall-Kugelfräser**  
Tapered solid carbide ball nose end mills

**N**

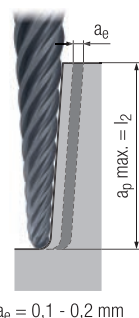

**Gültig für · Valid for**  
3548L

Für die Berechnung der Drehzahl n muss mit dem mittleren Durchmesser  $d_m$  (Messpunkt bei  $0,5 \times a_p$ ) gerechnet werden.

For the calculation of rpm (n), use the average diameter  $d_m$  (measuring point at  $0.5 \times a_p$ ).

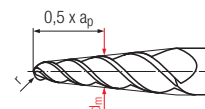

$$n = \frac{v_c \times 1000}{d_m \times \pi} \text{ [min}^{-1}\text{]}$$

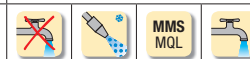

|          | $v_c$<br>[m/min] | $f_z$<br>[mm] |      |  |   |   |
|----------|------------------|---------------|------|--|---|---|
| <b>P</b> | 1.1              | 80            | 0,05 |  | ■ | □ |
|          | 2.1              | 70            | 0,04 |  | ■ | □ |
|          | 3.1              | 60            | 0,04 |  | ■ | □ |
|          | 4.1              | 60            | 0,03 |  | ■ |   |
|          | 5.1              | 50            | 0,03 |  | ■ |   |
| <b>M</b> | 1.1              | 60            | 0,03 |  |   | ■ |
|          | 2.1              | 60            | 0,03 |  |   | ■ |
|          | 3.1              | 50            | 0,03 |  |   | ■ |
|          | 4.1              | 50            | 0,03 |  |   | ■ |
| <b>K</b> | 1.1              |               |      |  |   |   |
|          | 1.2              |               |      |  |   |   |
|          | 2.1              |               |      |  |   |   |
|          | 2.2              |               |      |  |   |   |
|          | 3.1              |               |      |  |   |   |
|          | 3.2              |               |      |  |   |   |
|          | 4.1              |               |      |  |   |   |
| <b>N</b> | 1.1              |               |      |  |   |   |
|          | 1.2              |               |      |  |   |   |
|          | 1.3              | 200           | 0,06 |  |   | ■ |
|          | 1.4              | 140           | 0,06 |  |   | ■ |
|          | 1.5              | 100           | 0,06 |  |   | ■ |
|          | 1.6              |               |      |  |   |   |
|          | 2.1              |               |      |  |   |   |
|          | 2.2              |               |      |  |   |   |
|          | 2.3              |               |      |  |   |   |
|          | 2.4              |               |      |  |   |   |
|          | 2.5              |               |      |  |   |   |
|          | 2.6              |               |      |  |   |   |
|          | 2.7              |               |      |  |   |   |
|          | 2.8              |               |      |  |   |   |
|          | 3.1              |               |      |  |   |   |
|          | 3.2              |               |      |  |   |   |
| 4.1      |                  |               |      |  |   |   |
| 4.2      |                  |               |      |  |   |   |
| 4.3      |                  |               |      |  |   |   |
| 4.4      |                  |               |      |  |   |   |
| 5.1      |                  |               |      |  |   |   |
| 5.2      |                  |               |      |  |   |   |
| 5.3      |                  |               |      |  |   |   |
| <b>S</b> | 1.1              | 60            | 0,03 |  |   | ■ |
|          | 1.2              | 50            | 0,03 |  |   | ■ |
|          | 1.3              | 30            | 0,03 |  |   | ■ |
|          | 2.1              |               |      |  |   |   |
|          | 2.2              | 15            | 0,03 |  |   | ■ |
|          | 2.3              | 15            | 0,03 |  |   | ■ |
|          | 2.4              | 15            | 0,03 |  |   | ■ |
| 2.5      | 10               | 0,03          |      |  | ■ |   |
| 2.6      | 15               | 0,03          |      |  | ■ |   |
| <b>H</b> | 1.1              |               |      |  |   |   |
|          | 1.2              |               |      |  |   |   |
|          | 1.3              |               |      |  |   |   |
|          | 1.4              |               |      |  |   |   |
|          | 1.5              |               |      |  |   |   |

$v_c$  = Schnittgeschwindigkeit · Cutting speed  
 $f_z$  = Vorschub pro Zahn · Feed per tooth

■ = sehr gut geeignet · very suitable  
□ = gut geeignet · suitable

- Hochleistungswerkzeug
- Mit 3 Schneiden im Radius
- 6 Umfangsschneiden

- High performance tool
- 3 flutes in the ball nose section
- 6 radial flutes

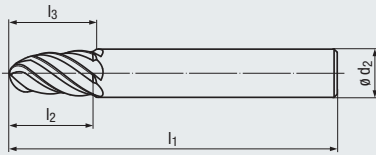
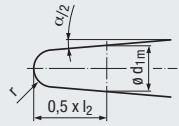

**N**

**HM** **DIN 6535**  
HA  
HB

**38°** **Kugel**

**Optional**



**Allround**

**Beschichtung · Coating**

**TIALN**

**Einsatzgebiete – Material (siehe Seite 4)**

- Speziell für hochfeste Werkstoffe geeignet
- Auch für Nickel-Basis-Legierungen einsetzbar
- Für die Zerspänung von Titan-Legierungen geeignet
- Einsatz in allen Turbinenwerkstoffen möglich

**Applications – material (see page 4)**

- Especially suitable for high-strength materials
- Also suitable in nickel-base alloys
- For the machining of titanium alloys
- Suitable in all turbine materials

**P** 1.1-5.1

**M** 1.1-4.1

**K** 1.1-4.2

**N** 2.1-2.8

**S** 1.1-2.6

**Bestell-Code · Order code**

**2679A**

| $\alpha/2$ | r<br>$\pm 0,01$ | $l_2$ | $l_3$ | $l_1$ | $d_{1m}$ | $\varnothing d_2$<br>h6 | Z<br>(Flutes) | Dimens.-<br>Code |   |  |  |
|------------|-----------------|-------|-------|-------|----------|-------------------------|---------------|------------------|---|--|--|
| <b>4°</b>  | <b>3</b>        | 30    | 47    | 108   | 7,89     | 12                      | <b>3/6</b>    | <b>.04030A</b>   | ● |  |  |
|            | <b>3,5</b>      | 39    | 39    | 108   | 9,26     | 12                      | <b>3/6</b>    | <b>.04035A</b>   | ● |  |  |
|            | <b>4</b>        | 32    | 32    | 108   | 9,70     | 12                      | <b>3/6</b>    | <b>.04040A</b>   | ● |  |  |
|            | <b>5</b>        | 35    | 49    | 108   | 11,77    | 16                      | <b>3/6</b>    | <b>.04050A</b>   | ● |  |  |
|            | <b>6</b>        | 34    | 34    | 108   | 13,57    | 16                      | <b>3/6</b>    | <b>.04060A</b>   | ● |  |  |
|            | <b>8</b>        | 36    | 36    | 108   | 17,44    | 20                      | <b>3/6</b>    | <b>.04080A</b>   | ● |  |  |

**Konische Hartmetall-Kugelfräser**  
Tapered solid carbide ball nose end mills

**N**

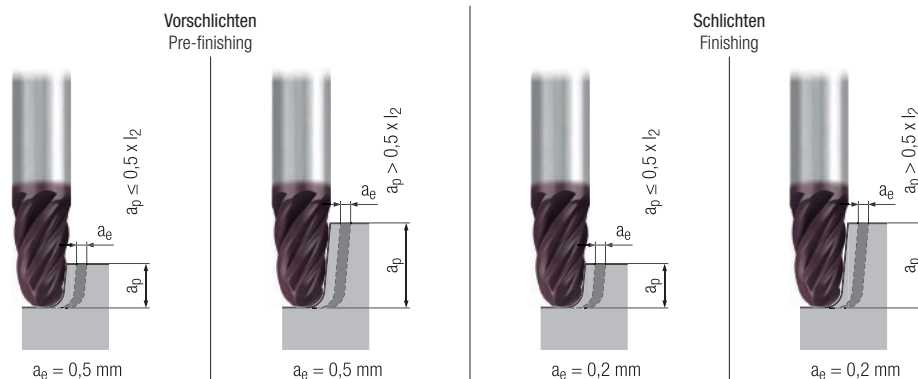

**Gültig für · Valid for**  
2679A

Für die Berechnung der Drehzahl n muss mit dem mittleren Durchmesser  $d_m$  (Messpunkt bei  $0,5 \times a_p$ ) gerechnet werden.

For the calculation of rpm (n), use the average diameter  $d_m$  (measuring point at  $0,5 \times a_p$ ).

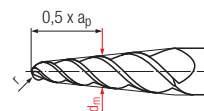

$$n = \frac{v_c \times 1000}{d_m \times \pi} \text{ [min}^{-1}\text{]}$$

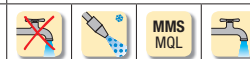

|          |     | Vorschlichten Pre-finishing |            | Schlichten Finishing |            |           |           |           |                          |                                     |                                     |                                     |                                     |
|----------|-----|-----------------------------|------------|----------------------|------------|-----------|-----------|-----------|--------------------------|-------------------------------------|-------------------------------------|-------------------------------------|-------------------------------------|
|          |     | $v_c$ [m/min]               | $f_z$ [mm] | $v_c$ [m/min]        | $f_z$ [mm] |           |           |           |                          | $v_c$ [m/min]                       | $f_z$ [mm]                          |                                     |                                     |
| <b>P</b> | 1.1 | 130                         | 0,008 x r  | 100                  | 0,007 x r  | 160       | 0,011 x r | 120       | 0,009 x r                | <input type="checkbox"/>            | <input checked="" type="checkbox"/> | <input type="checkbox"/>            | <input checked="" type="checkbox"/> |
|          | 2.1 | 120                         | 0,007 x r  | 90                   | 0,006 x r  | 150       | 0,010 x r | 110       | 0,008 x r                | <input type="checkbox"/>            | <input checked="" type="checkbox"/> | <input type="checkbox"/>            | <input checked="" type="checkbox"/> |
|          | 3.1 | 110                         | 0,006 x r  | 90                   | 0,006 x r  | 140       | 0,009 x r | 100       | 0,007 x r                | <input type="checkbox"/>            | <input checked="" type="checkbox"/> | <input type="checkbox"/>            | <input type="checkbox"/>            |
|          | 4.1 | 110                         | 0,006 x r  | 80                   | 0,005 x r  | 130       | 0,008 x r | 100       | 0,006 x r                | <input type="checkbox"/>            | <input checked="" type="checkbox"/> | <input type="checkbox"/>            | <input type="checkbox"/>            |
|          | 5.1 | 100                         | 0,005 x r  | 80                   | 0,004 x r  | 120       | 0,007 x r | 90        | 0,005 x r                | <input type="checkbox"/>            | <input checked="" type="checkbox"/> | <input type="checkbox"/>            | <input type="checkbox"/>            |
| <b>M</b> | 1.1 | 70                          | 0,006 x r  | 60                   | 0,005 x r  | 90        | 0,008 x r | 70        | 0,006 x r                |                                     |                                     | <input type="checkbox"/>            | <input checked="" type="checkbox"/> |
|          | 2.1 | 60                          | 0,005 x r  | 50                   | 0,004 x r  | 80        | 0,007 x r | 60        | 0,005 x r                |                                     |                                     | <input type="checkbox"/>            | <input checked="" type="checkbox"/> |
|          | 3.1 | 50                          | 0,004 x r  | 40                   | 0,004 x r  | 60        | 0,006 x r | 40        | 0,005 x r                |                                     |                                     | <input type="checkbox"/>            | <input checked="" type="checkbox"/> |
|          | 4.1 | 30                          | 0,004 x r  | 30                   | 0,003 x r  | 40        | 0,005 x r | 30        | 0,004 x r                |                                     |                                     | <input type="checkbox"/>            | <input checked="" type="checkbox"/> |
| <b>K</b> | 1.1 | 150                         | 0,010 x r  | 120                  | 0,008 x r  | 190       | 0,013 x r | 140       | 0,011 x r                | <input type="checkbox"/>            | <input checked="" type="checkbox"/> | <input type="checkbox"/>            | <input type="checkbox"/>            |
|          | 1.2 | 150                         | 0,010 x r  | 120                  | 0,008 x r  | 190       | 0,013 x r | 140       | 0,011 x r                | <input type="checkbox"/>            | <input checked="" type="checkbox"/> | <input type="checkbox"/>            | <input type="checkbox"/>            |
|          | 2.1 | 140                         | 0,009 x r  | 110                  | 0,008 x r  | 170       | 0,012 x r | 130       | 0,010 x r                | <input type="checkbox"/>            | <input checked="" type="checkbox"/> | <input type="checkbox"/>            | <input type="checkbox"/>            |
|          | 2.2 | 140                         | 0,009 x r  | 110                  | 0,008 x r  | 170       | 0,012 x r | 130       | 0,010 x r                | <input type="checkbox"/>            | <input checked="" type="checkbox"/> | <input type="checkbox"/>            | <input type="checkbox"/>            |
|          | 3.1 | 130                         | 0,008 x r  | 100                  | 0,007 x r  | 160       | 0,011 x r | 120       | 0,009 x r                | <input type="checkbox"/>            | <input checked="" type="checkbox"/> | <input type="checkbox"/>            | <input type="checkbox"/>            |
|          | 3.2 | 130                         | 0,008 x r  | 100                  | 0,007 x r  | 160       | 0,011 x r | 120       | 0,009 x r                | <input type="checkbox"/>            | <input checked="" type="checkbox"/> | <input type="checkbox"/>            | <input type="checkbox"/>            |
|          | 4.1 | 110                         | 0,007 x r  | 90                   | 0,006 x r  | 140       | 0,010 x r | 100       | 0,008 x r                | <input type="checkbox"/>            | <input checked="" type="checkbox"/> | <input type="checkbox"/>            | <input type="checkbox"/>            |
| 4.2      | 100 | 0,006 x r                   | 80         | 0,006 x r            | 120        | 0,009 x r | 90        | 0,007 x r | <input type="checkbox"/> | <input checked="" type="checkbox"/> | <input type="checkbox"/>            | <input type="checkbox"/>            |                                     |
| <b>N</b> | 1.1 |                             |            |                      |            |           |           |           |                          |                                     |                                     |                                     |                                     |
|          | 1.2 |                             |            |                      |            |           |           |           |                          |                                     |                                     |                                     |                                     |
|          | 1.3 |                             |            |                      |            |           |           |           |                          |                                     |                                     |                                     |                                     |
|          | 1.4 |                             |            |                      |            |           |           |           |                          |                                     |                                     |                                     |                                     |
|          | 1.5 |                             |            |                      |            |           |           |           |                          |                                     |                                     |                                     |                                     |
|          | 1.6 |                             |            |                      |            |           |           |           |                          |                                     |                                     |                                     |                                     |
|          | 2.1 | 160                         | 0,008 x r  | 130                  | 0,007 x r  | 200       | 0,011 x r | 150       | 0,009 x r                |                                     |                                     | <input type="checkbox"/>            | <input checked="" type="checkbox"/> |
|          | 2.2 | 160                         | 0,008 x r  | 130                  | 0,007 x r  | 200       | 0,011 x r | 150       | 0,009 x r                |                                     |                                     | <input type="checkbox"/>            | <input checked="" type="checkbox"/> |
|          | 2.3 | 160                         | 0,008 x r  | 130                  | 0,007 x r  | 200       | 0,011 x r | 150       | 0,009 x r                |                                     |                                     | <input type="checkbox"/>            | <input checked="" type="checkbox"/> |
|          | 2.4 | 140                         | 0,006 x r  | 110                  | 0,006 x r  | 170       | 0,009 x r | 130       | 0,007 x r                |                                     |                                     | <input type="checkbox"/>            | <input checked="" type="checkbox"/> |
|          | 2.5 | 140                         | 0,006 x r  | 110                  | 0,006 x r  | 170       | 0,009 x r | 130       | 0,007 x r                |                                     |                                     | <input type="checkbox"/>            | <input checked="" type="checkbox"/> |
|          | 2.6 | 140                         | 0,006 x r  | 110                  | 0,006 x r  | 170       | 0,009 x r | 130       | 0,007 x r                |                                     |                                     | <input type="checkbox"/>            | <input checked="" type="checkbox"/> |
|          | 2.7 | 90                          | 0,006 x r  | 70                   | 0,005 x r  | 110       | 0,008 x r | 80        | 0,006 x r                |                                     |                                     | <input type="checkbox"/>            | <input checked="" type="checkbox"/> |
|          | 2.8 | 90                          | 0,006 x r  | 70                   | 0,005 x r  | 110       | 0,008 x r | 80        | 0,006 x r                |                                     |                                     | <input type="checkbox"/>            | <input checked="" type="checkbox"/> |
|          | 3.1 |                             |            |                      |            |           |           |           |                          |                                     |                                     |                                     |                                     |
|          | 3.2 |                             |            |                      |            |           |           |           |                          |                                     |                                     |                                     |                                     |
| 4.1      |     |                             |            |                      |            |           |           |           |                          |                                     |                                     |                                     |                                     |
| 4.2      |     |                             |            |                      |            |           |           |           |                          |                                     |                                     |                                     |                                     |
| 4.3      |     |                             |            |                      |            |           |           |           |                          |                                     |                                     |                                     |                                     |
| 4.4      |     |                             |            |                      |            |           |           |           |                          |                                     |                                     |                                     |                                     |
| 5.1      |     |                             |            |                      |            |           |           |           |                          |                                     |                                     |                                     |                                     |
| 5.2      |     |                             |            |                      |            |           |           |           |                          |                                     |                                     |                                     |                                     |
| 5.3      |     |                             |            |                      |            |           |           |           |                          |                                     |                                     |                                     |                                     |
| <b>S</b> | 1.1 | 100                         | 0,008 x r  | 80                   | 0,007 x r  | 120       | 0,011 x r | 90        | 0,009 x r                |                                     |                                     | <input type="checkbox"/>            | <input checked="" type="checkbox"/> |
|          | 1.2 | 70                          | 0,007 x r  | 60                   | 0,006 x r  | 90        | 0,010 x r | 70        | 0,008 x r                |                                     |                                     | <input type="checkbox"/>            | <input checked="" type="checkbox"/> |
|          | 1.3 | 50                          | 0,006 x r  | 40                   | 0,006 x r  | 60        | 0,009 x r | 40        | 0,007 x r                |                                     |                                     | <input type="checkbox"/>            | <input checked="" type="checkbox"/> |
|          | 2.1 | 70                          | 0,007 x r  | 50                   | 0,006 x r  | 90        | 0,010 x r | 60        | 0,008 x r                |                                     |                                     | <input type="checkbox"/>            | <input checked="" type="checkbox"/> |
|          | 2.2 | 30                          | 0,006 x r  | 20                   | 0,005 x r  | 40        | 0,008 x r | 30        | 0,006 x r                |                                     |                                     | <input type="checkbox"/>            | <input checked="" type="checkbox"/> |
|          | 2.3 | 20                          | 0,005 x r  | 20                   | 0,004 x r  | 30        | 0,007 x r | 20        | 0,005 x r                |                                     |                                     | <input type="checkbox"/>            | <input checked="" type="checkbox"/> |
|          | 2.4 | 30                          | 0,006 x r  | 20                   | 0,005 x r  | 40        | 0,008 x r | 30        | 0,006 x r                |                                     |                                     | <input type="checkbox"/>            | <input checked="" type="checkbox"/> |
| 2.5      | 20  | 0,005 x r                   | 10         | 0,004 x r            | 20         | 0,007 x r | 20        | 0,005 x r |                          |                                     | <input type="checkbox"/>            | <input checked="" type="checkbox"/> |                                     |
| 2.6      | 20  | 0,004 x r                   | 20         | 0,004 x r            | 30         | 0,006 x r | 20        | 0,005 x r |                          |                                     | <input type="checkbox"/>            | <input checked="" type="checkbox"/> |                                     |
| <b>H</b> | 1.1 |                             |            |                      |            |           |           |           |                          |                                     |                                     |                                     |                                     |
|          | 1.2 |                             |            |                      |            |           |           |           |                          |                                     |                                     |                                     |                                     |
|          | 1.3 |                             |            |                      |            |           |           |           |                          |                                     |                                     |                                     |                                     |
|          | 1.4 |                             |            |                      |            |           |           |           |                          |                                     |                                     |                                     |                                     |
|          | 1.5 |                             |            |                      |            |           |           |           |                          |                                     |                                     |                                     |                                     |

$v_c$  = Schnittgeschwindigkeit · Cutting speed  
 $f_z$  = Vorschub pro Zahn · Feed per tooth

■ = sehr gut geeignet · very suitable  
□ = gut geeignet · suitable

- Hochleistungswerkzeug
- Patentierte Querschneide
- Mit 4 Schneiden
- 2 Schneiden zur Mitte
- Kurze, stabile Schneidenlänge
- 2 Baulängen verfügbar

- High performance tool
- Patented chisel edge
- With 4 flutes
- 2 centre cutting edges
- Short, stable flute length
- 2 lengths available

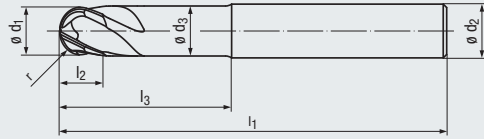

**Design I<sub>4</sub>:**

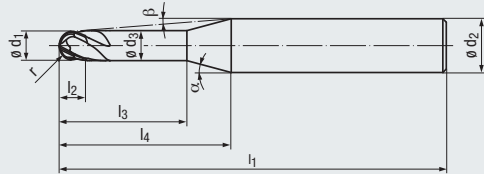

**H**

**HM**

**DIN 6535**  
HA  
HB

**30°**

**Kugel**

**3-5°**

**Optional**  
≤ 66 HRC



**Hard materials**

**Beschichtung · Coating**

**TIALN**

**Einsatzgebiete – Material (siehe Seite 4)**

- Zur Bearbeitung harter Werkstoffe
- Zur Schlichtbearbeitung mit sehr guter Oberflächenqualität
- Zum HSC-Schlichten geeignet

**Applications – material (see page 4)**

- For machining hard materials
- For finishing with very high surface quality
- Suitable for HSC finishing

|          |              |              |
|----------|--------------|--------------|
| <b>P</b> | 3.1-5.1      | 1.1-2.1      |
| <b>K</b> | 1.1-4.2      |              |
| <b>N</b> | 2.3, 2.6-2.8 |              |
| <b>N</b> |              | 2.2, 2.4-2.5 |
| <b>H</b> | 1.1-1.5      |              |

**Kurze Ausführung · Short design**

| Bestell-Code · Order code |             |       |       |       |            |       |                  |          |         |               |                  | 2834A |  |  |  |
|---------------------------|-------------|-------|-------|-------|------------|-------|------------------|----------|---------|---------------|------------------|-------|--|--|--|
| $\phi d_1$<br>±0,01       | r<br>±0,005 | $l_2$ | $l_3$ | $l_1$ | $\phi d_3$ | $l_4$ | $\phi d_2$<br>h5 | $\alpha$ | $\beta$ | Z<br>(Flutes) | Dimens.-<br>Code |       |  |  |  |
| 3                         | 1,5         | 3,5   | 10    | 57    | 2,8        | 20    | 6                | 11,5°    | 5°      | 4             | .003             | ●     |  |  |  |
| 4                         | 2           | 4     | 12    | 57    | 3,8        | 20    | 6                | 11°      | 3,5°    | 4             | .004             | ●     |  |  |  |
| 5                         | 2,5         | 5     | 14    | 57    | 4,7        | 20    | 6                | 10°      | 2°      | 4             | .005             | ●     |  |  |  |
| 6                         | 3           | 6     | 20    | 57    | 5,6        | –     | 6                | –        | –       | 4             | .006             | ●     |  |  |  |
| 8                         | 4           | 7     | 25    | 63    | 7,6        | –     | 8                | –        | –       | 4             | .008             | ●     |  |  |  |
| 10                        | 5           | 8     | 30    | 72    | 9,6        | –     | 10               | –        | –       | 4             | .010             | ●     |  |  |  |
| 12                        | 6           | 10    | 35    | 83    | 11,5       | –     | 12               | –        | –       | 4             | .012             | ●     |  |  |  |

Werkzeug mit seitlicher Mitnahmefläche: Bestell-Code 2835A  
Tool with side-lock clamping: order code 2835A



15-90° Alle Schneiden effektiv im Einsatz  
All cutting edges in operation

0-15° 2 Schneiden effektiv im Einsatz  
2 cutting edges in operation



**Hartmetall-Kugelfräser – kurze Ausführung (4 Schneiden)**  
Solid carbide ball nose end mills – short design (4 flutes)

Gültig für · Valid for  
2834A

**H**

Schruppen (4 Schneiden)  
Roughing (4 flutes)

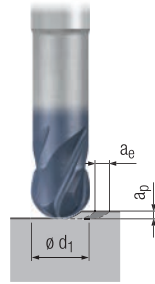

Schlichten (4 Schneiden)  
Finishing (4 flutes)

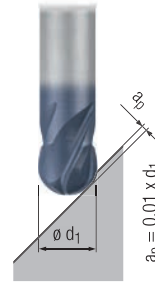

|          |     | $V_c$<br>[m/min] | $f_z$<br>[mm]      | $a_e$<br>[mm]     | $a_p$<br>[mm]     | $V_c$<br>[m/min] | $f_z$<br>[mm]       |                          |                                     |                          |                                     |
|----------|-----|------------------|--------------------|-------------------|-------------------|------------------|---------------------|--------------------------|-------------------------------------|--------------------------|-------------------------------------|
|          |     |                  |                    |                   |                   |                  |                     |                          |                                     | MMS<br>MQL               |                                     |
| <b>P</b> | 1.1 | 280              | $0,011 \times d_1$ | $0,1 \times d_1$  | $0,05 \times d_1$ | 360              | $0,008 \times d_1$  | <input type="checkbox"/> | <input checked="" type="checkbox"/> | <input type="checkbox"/> | <input checked="" type="checkbox"/> |
|          | 2.1 | 240              | $0,011 \times d_1$ | $0,1 \times d_1$  | $0,05 \times d_1$ | 320              | $0,008 \times d_1$  | <input type="checkbox"/> | <input checked="" type="checkbox"/> | <input type="checkbox"/> | <input checked="" type="checkbox"/> |
|          | 3.1 | 210              | $0,009 \times d_1$ | $0,1 \times d_1$  | $0,05 \times d_1$ | 270              | $0,007 \times d_1$  | <input type="checkbox"/> | <input checked="" type="checkbox"/> | <input type="checkbox"/> |                                     |
|          | 4.1 | 170              | $0,008 \times d_1$ | $0,1 \times d_1$  | $0,05 \times d_1$ | 220              | $0,006 \times d_1$  | <input type="checkbox"/> | <input checked="" type="checkbox"/> | <input type="checkbox"/> |                                     |
|          | 5.1 | 140              | $0,006 \times d_1$ | $0,1 \times d_1$  | $0,05 \times d_1$ | 180              | $0,0054 \times d_1$ | <input type="checkbox"/> | <input checked="" type="checkbox"/> | <input type="checkbox"/> |                                     |
| <b>M</b> | 1.1 |                  |                    |                   |                   |                  |                     |                          |                                     |                          |                                     |
|          | 2.1 |                  |                    |                   |                   |                  |                     |                          |                                     |                          |                                     |
|          | 3.1 |                  |                    |                   |                   |                  |                     |                          |                                     |                          |                                     |
|          | 4.1 |                  |                    |                   |                   |                  |                     |                          |                                     |                          |                                     |
| <b>K</b> | 1.1 | 280              | $0,011 \times d_1$ | $0,1 \times d_1$  | $0,05 \times d_1$ | 360              | $0,008 \times d_1$  | <input type="checkbox"/> | <input checked="" type="checkbox"/> | <input type="checkbox"/> | <input type="checkbox"/>            |
|          | 1.2 | 280              | $0,011 \times d_1$ | $0,1 \times d_1$  | $0,05 \times d_1$ | 360              | $0,008 \times d_1$  | <input type="checkbox"/> | <input checked="" type="checkbox"/> | <input type="checkbox"/> | <input type="checkbox"/>            |
|          | 2.1 | 250              | $0,009 \times d_1$ | $0,1 \times d_1$  | $0,05 \times d_1$ | 320              | $0,006 \times d_1$  | <input type="checkbox"/> | <input checked="" type="checkbox"/> | <input type="checkbox"/> | <input type="checkbox"/>            |
|          | 2.2 | 250              | $0,009 \times d_1$ | $0,1 \times d_1$  | $0,05 \times d_1$ | 320              | $0,006 \times d_1$  | <input type="checkbox"/> | <input checked="" type="checkbox"/> | <input type="checkbox"/> | <input type="checkbox"/>            |
|          | 3.1 | 210              | $0,009 \times d_1$ | $0,1 \times d_1$  | $0,05 \times d_1$ | 270              | $0,006 \times d_1$  | <input type="checkbox"/> | <input checked="" type="checkbox"/> | <input type="checkbox"/> | <input type="checkbox"/>            |
|          | 3.2 | 210              | $0,009 \times d_1$ | $0,1 \times d_1$  | $0,05 \times d_1$ | 270              | $0,006 \times d_1$  | <input type="checkbox"/> | <input checked="" type="checkbox"/> | <input type="checkbox"/> | <input type="checkbox"/>            |
|          | 4.1 | 170              | $0,006 \times d_1$ | $0,1 \times d_1$  | $0,05 \times d_1$ | 220              | $0,005 \times d_1$  | <input type="checkbox"/> | <input checked="" type="checkbox"/> | <input type="checkbox"/> | <input type="checkbox"/>            |
|          | 4.2 | 150              | $0,006 \times d_1$ | $0,1 \times d_1$  | $0,05 \times d_1$ | 180              | $0,005 \times d_1$  | <input type="checkbox"/> | <input checked="" type="checkbox"/> | <input type="checkbox"/> | <input type="checkbox"/>            |
| <b>N</b> | 1.1 |                  |                    |                   |                   |                  |                     |                          |                                     |                          |                                     |
|          | 1.2 |                  |                    |                   |                   |                  |                     |                          |                                     |                          |                                     |
|          | 1.3 |                  |                    |                   |                   |                  |                     |                          |                                     |                          |                                     |
|          | 1.4 |                  |                    |                   |                   |                  |                     |                          |                                     |                          |                                     |
|          | 1.5 |                  |                    |                   |                   |                  |                     |                          |                                     |                          |                                     |
|          | 1.6 |                  |                    |                   |                   |                  |                     |                          |                                     |                          |                                     |
|          | 2.1 |                  |                    |                   |                   |                  |                     |                          |                                     |                          |                                     |
|          | 2.2 | 250              | $0,011 \times d_1$ | $0,1 \times d_1$  | $0,05 \times d_1$ | 320              | $0,008 \times d_1$  |                          |                                     | <input type="checkbox"/> | <input checked="" type="checkbox"/> |
|          | 2.3 | 250              | $0,011 \times d_1$ | $0,1 \times d_1$  | $0,05 \times d_1$ | 320              | $0,008 \times d_1$  | <input type="checkbox"/> | <input type="checkbox"/>            | <input type="checkbox"/> | <input checked="" type="checkbox"/> |
|          | 2.4 | 210              | $0,009 \times d_1$ | $0,1 \times d_1$  | $0,05 \times d_1$ | 270              | $0,007 \times d_1$  |                          |                                     | <input type="checkbox"/> | <input checked="" type="checkbox"/> |
|          | 2.5 | 210              | $0,009 \times d_1$ | $0,1 \times d_1$  | $0,05 \times d_1$ | 270              | $0,007 \times d_1$  |                          |                                     | <input type="checkbox"/> | <input checked="" type="checkbox"/> |
|          | 2.6 | 210              | $0,009 \times d_1$ | $0,1 \times d_1$  | $0,05 \times d_1$ | 270              | $0,007 \times d_1$  | <input type="checkbox"/> | <input type="checkbox"/>            | <input type="checkbox"/> | <input checked="" type="checkbox"/> |
|          | 2.7 | 130              | $0,006 \times d_1$ | $0,1 \times d_1$  | $0,05 \times d_1$ | 170              | $0,006 \times d_1$  |                          |                                     | <input type="checkbox"/> | <input checked="" type="checkbox"/> |
|          | 2.8 | 130              | $0,006 \times d_1$ | $0,1 \times d_1$  | $0,05 \times d_1$ | 170              | $0,005 \times d_1$  |                          |                                     | <input type="checkbox"/> | <input checked="" type="checkbox"/> |
|          | 3.1 |                  |                    |                   |                   |                  |                     |                          |                                     |                          |                                     |
|          | 3.2 |                  |                    |                   |                   |                  |                     |                          |                                     |                          |                                     |
| 4.1      |     |                  |                    |                   |                   |                  |                     |                          |                                     |                          |                                     |
| 4.2      |     |                  |                    |                   |                   |                  |                     |                          |                                     |                          |                                     |
| 4.3      |     |                  |                    |                   |                   |                  |                     |                          |                                     |                          |                                     |
| 4.4      |     |                  |                    |                   |                   |                  |                     |                          |                                     |                          |                                     |
| 5.1      |     |                  |                    |                   |                   |                  |                     |                          |                                     |                          |                                     |
| 5.2      |     |                  |                    |                   |                   |                  |                     |                          |                                     |                          |                                     |
| 5.3      |     |                  |                    |                   |                   |                  |                     |                          |                                     |                          |                                     |
| <b>S</b> | 1.1 |                  |                    |                   |                   |                  |                     |                          |                                     |                          |                                     |
|          | 1.2 |                  |                    |                   |                   |                  |                     |                          |                                     |                          |                                     |
|          | 1.3 |                  |                    |                   |                   |                  |                     |                          |                                     |                          |                                     |
|          | 2.1 |                  |                    |                   |                   |                  |                     |                          |                                     |                          |                                     |
|          | 2.2 |                  |                    |                   |                   |                  |                     |                          |                                     |                          |                                     |
|          | 2.6 |                  |                    |                   |                   |                  |                     |                          |                                     |                          |                                     |
| <b>H</b> | 1.1 | 130              | $0,008 \times d_1$ | $0,05 \times d_1$ | $0,02 \times d_1$ | 180              | $0,006 \times d_1$  | <input type="checkbox"/> | <input checked="" type="checkbox"/> |                          |                                     |
|          | 1.2 | 120              | $0,007 \times d_1$ | $0,05 \times d_1$ | $0,02 \times d_1$ | 160              | $0,005 \times d_1$  | <input type="checkbox"/> | <input checked="" type="checkbox"/> |                          |                                     |
|          | 1.3 |                  |                    |                   |                   | 140              | $0,005 \times d_1$  | <input type="checkbox"/> | <input checked="" type="checkbox"/> |                          |                                     |
|          | 1.4 |                  |                    |                   |                   | 110              | $0,004 \times d_1$  | <input type="checkbox"/> | <input checked="" type="checkbox"/> |                          |                                     |
|          | 1.5 |                  |                    |                   |                   | 90               | $0,003 \times d_1$  | <input type="checkbox"/> | <input checked="" type="checkbox"/> |                          |                                     |

$v_c$  = Schnittgeschwindigkeit · Cutting speed  
 $f_z$  = Vorschub pro Zahn · Feed per tooth

■ = sehr gut geeignet · very suitable  
□ = gut geeignet · suitable

- Hochleistungswerkzeug
- Patentierte Querschneide
- Mit 4 Schneiden
- 4 Schneiden zur Mitte
- Kurze, stabile Schneidenlänge
- 2 Baulängen verfügbar

- High performance tool
- Patented chisel edge
- With 4 flutes
- 4 centre cutting edges
- Short, stable flute length
- 2 lengths available

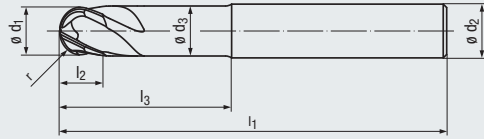

### Design I<sub>4</sub>:

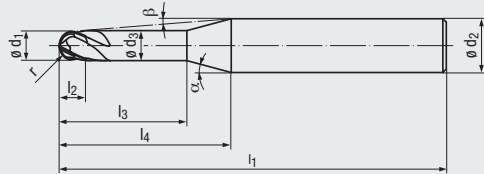

**H**

**HM**

**DIN 6535**  
HA  
HB

**30°**

**Kugel**

**3-5°**

**Optional**  
≤ 66 HRC



**Hard materials**

### Beschichtung · Coating

**TIALN**

### Einsatzgebiete – Material (siehe Seite 4)

- Zur Bearbeitung harter Werkstoffe
- Zur Schlichtbearbeitung mit sehr guter Oberflächenqualität
- Zum HSC-Schlichten geeignet

### Applications – material (see page 4)

- For machining hard materials
- For finishing with very high surface quality
- Suitable for HSC finishing

|          |              |              |
|----------|--------------|--------------|
| <b>P</b> | 3.1-5.1      | 1.1-2.1      |
| <b>K</b> | 1.1-4.2      |              |
| <b>N</b> | 2.3, 2.6-2.8 |              |
| <b>N</b> |              | 2.2, 2.4-2.5 |
| <b>S</b> | 1.1-2.6      |              |
| <b>H</b> | 1.1-1.5      |              |

### Lange Ausführung · Long design

#### Bestell-Code · Order code

**2842A**

| $\phi d_1$<br>±0,01 | r<br>±0,005 | $l_2$ | $l_3$ | $l_1$ | $\phi d_3$ | $l_4$ | $\phi d_2$<br>h5 | $\alpha$ | $\beta$ | Z<br>(Flutes) | Dimens.-<br>Code |   |  |  |
|---------------------|-------------|-------|-------|-------|------------|-------|------------------|----------|---------|---------------|------------------|---|--|--|
| <b>6</b>            | 3           | 6     | 30    | 80    | 5,6        | –     | 6                | –        | –       | <b>4</b>      | <b>.006</b>      | ● |  |  |
| <b>8</b>            | 4           | 7     | 35    | 80    | 7,6        | –     | 8                | –        | –       | <b>4</b>      | <b>.008</b>      | ● |  |  |
| <b>10</b>           | 5           | 8     | 45    | 100   | 9,6        | –     | 10               | –        | –       | <b>4</b>      | <b>.010</b>      | ● |  |  |
| <b>12</b>           | 6           | 10    | 50    | 100   | 11,5       | –     | 12               | –        | –       | <b>4</b>      | <b>.012</b>      | ● |  |  |



Werkzeug mit seitlicher Mitnahmeffläche: Bestell-Code 2843A  
Tool with side-lock clamping: order code 2843A





**Hartmetall-Kugelfräser – lange Ausführung (4 Schneiden)**  
Solid carbide ball nose end mills – long design (4 flutes)

Gültig für · Valid for  
2842A

**H**

Schruppen (4 Schneiden)  
Roughing (4 flutes)

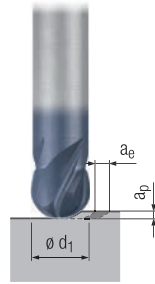

Schlichten (4 Schneiden)  
Finishing (4 flutes)

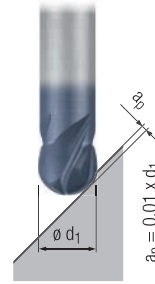

|          |     | $V_c$<br>[m/min] | $f_z$<br>[mm]      | $a_e$<br>[mm]     | $a_p$<br>[mm]     | $V_c$<br>[m/min]   | $f_z$<br>[mm]       |                          |                                     |                                     |                                     |
|----------|-----|------------------|--------------------|-------------------|-------------------|--------------------|---------------------|--------------------------|-------------------------------------|-------------------------------------|-------------------------------------|
|          |     |                  |                    |                   |                   |                    |                     |                          |                                     | MMS<br>MQL                          |                                     |
| <b>P</b> | 1.1 | 280              | $0,011 \times d_1$ | $0,1 \times d_1$  | $0,05 \times d_1$ | 360                | $0,008 \times d_1$  | <input type="checkbox"/> | <input checked="" type="checkbox"/> | <input type="checkbox"/>            | <input checked="" type="checkbox"/> |
|          | 2.1 | 240              | $0,011 \times d_1$ | $0,1 \times d_1$  | $0,05 \times d_1$ | 320                | $0,008 \times d_1$  | <input type="checkbox"/> | <input checked="" type="checkbox"/> | <input type="checkbox"/>            | <input checked="" type="checkbox"/> |
|          | 3.1 | 210              | $0,009 \times d_1$ | $0,1 \times d_1$  | $0,05 \times d_1$ | 270                | $0,007 \times d_1$  | <input type="checkbox"/> | <input checked="" type="checkbox"/> | <input type="checkbox"/>            | <input type="checkbox"/>            |
|          | 4.1 | 170              | $0,008 \times d_1$ | $0,1 \times d_1$  | $0,05 \times d_1$ | 220                | $0,006 \times d_1$  | <input type="checkbox"/> | <input checked="" type="checkbox"/> | <input type="checkbox"/>            | <input type="checkbox"/>            |
|          | 5.1 | 140              | $0,006 \times d_1$ | $0,1 \times d_1$  | $0,05 \times d_1$ | 180                | $0,0054 \times d_1$ | <input type="checkbox"/> | <input checked="" type="checkbox"/> | <input type="checkbox"/>            | <input type="checkbox"/>            |
| <b>M</b> | 1.1 |                  |                    |                   |                   |                    |                     |                          |                                     |                                     |                                     |
|          | 2.1 |                  |                    |                   |                   |                    |                     |                          |                                     |                                     |                                     |
|          | 3.1 |                  |                    |                   |                   |                    |                     |                          |                                     |                                     |                                     |
|          | 4.1 |                  |                    |                   |                   |                    |                     |                          |                                     |                                     |                                     |
| <b>K</b> | 1.1 | 280              | $0,011 \times d_1$ | $0,1 \times d_1$  | $0,05 \times d_1$ | 360                | $0,008 \times d_1$  | <input type="checkbox"/> | <input checked="" type="checkbox"/> | <input type="checkbox"/>            | <input type="checkbox"/>            |
|          | 1.2 | 280              | $0,011 \times d_1$ | $0,1 \times d_1$  | $0,05 \times d_1$ | 360                | $0,008 \times d_1$  | <input type="checkbox"/> | <input checked="" type="checkbox"/> | <input type="checkbox"/>            | <input type="checkbox"/>            |
|          | 2.1 | 250              | $0,009 \times d_1$ | $0,1 \times d_1$  | $0,05 \times d_1$ | 320                | $0,006 \times d_1$  | <input type="checkbox"/> | <input checked="" type="checkbox"/> | <input type="checkbox"/>            | <input type="checkbox"/>            |
|          | 2.2 | 250              | $0,009 \times d_1$ | $0,1 \times d_1$  | $0,05 \times d_1$ | 320                | $0,006 \times d_1$  | <input type="checkbox"/> | <input checked="" type="checkbox"/> | <input type="checkbox"/>            | <input type="checkbox"/>            |
|          | 3.1 | 210              | $0,009 \times d_1$ | $0,1 \times d_1$  | $0,05 \times d_1$ | 270                | $0,006 \times d_1$  | <input type="checkbox"/> | <input checked="" type="checkbox"/> | <input type="checkbox"/>            | <input type="checkbox"/>            |
|          | 3.2 | 210              | $0,009 \times d_1$ | $0,1 \times d_1$  | $0,05 \times d_1$ | 270                | $0,006 \times d_1$  | <input type="checkbox"/> | <input checked="" type="checkbox"/> | <input type="checkbox"/>            | <input type="checkbox"/>            |
|          | 4.1 | 170              | $0,006 \times d_1$ | $0,1 \times d_1$  | $0,05 \times d_1$ | 220                | $0,005 \times d_1$  | <input type="checkbox"/> | <input checked="" type="checkbox"/> | <input type="checkbox"/>            | <input type="checkbox"/>            |
|          | 4.2 | 150              | $0,006 \times d_1$ | $0,1 \times d_1$  | $0,05 \times d_1$ | 180                | $0,005 \times d_1$  | <input type="checkbox"/> | <input checked="" type="checkbox"/> | <input type="checkbox"/>            | <input type="checkbox"/>            |
| <b>N</b> | 1.1 |                  |                    |                   |                   |                    |                     |                          |                                     |                                     |                                     |
|          | 1.2 |                  |                    |                   |                   |                    |                     |                          |                                     |                                     |                                     |
|          | 1.3 |                  |                    |                   |                   |                    |                     |                          |                                     |                                     |                                     |
|          | 1.4 |                  |                    |                   |                   |                    |                     |                          |                                     |                                     |                                     |
|          | 1.5 |                  |                    |                   |                   |                    |                     |                          |                                     |                                     |                                     |
|          | 1.6 |                  |                    |                   |                   |                    |                     |                          |                                     |                                     |                                     |
|          | 2.1 |                  |                    |                   |                   |                    |                     |                          |                                     |                                     |                                     |
|          | 2.2 | 250              | $0,011 \times d_1$ | $0,1 \times d_1$  | $0,05 \times d_1$ | 320                | $0,008 \times d_1$  |                          |                                     | <input type="checkbox"/>            | <input checked="" type="checkbox"/> |
|          | 2.3 | 250              | $0,011 \times d_1$ | $0,1 \times d_1$  | $0,05 \times d_1$ | 320                | $0,008 \times d_1$  | <input type="checkbox"/> | <input type="checkbox"/>            | <input type="checkbox"/>            | <input checked="" type="checkbox"/> |
|          | 2.4 | 210              | $0,009 \times d_1$ | $0,1 \times d_1$  | $0,05 \times d_1$ | 270                | $0,007 \times d_1$  |                          |                                     | <input type="checkbox"/>            | <input checked="" type="checkbox"/> |
|          | 2.5 | 210              | $0,009 \times d_1$ | $0,1 \times d_1$  | $0,05 \times d_1$ | 270                | $0,007 \times d_1$  |                          |                                     | <input type="checkbox"/>            | <input checked="" type="checkbox"/> |
|          | 2.6 | 210              | $0,009 \times d_1$ | $0,1 \times d_1$  | $0,05 \times d_1$ | 270                | $0,007 \times d_1$  | <input type="checkbox"/> | <input type="checkbox"/>            | <input type="checkbox"/>            | <input checked="" type="checkbox"/> |
|          | 2.7 | 130              | $0,006 \times d_1$ | $0,1 \times d_1$  | $0,05 \times d_1$ | 170                | $0,006 \times d_1$  |                          |                                     | <input type="checkbox"/>            | <input checked="" type="checkbox"/> |
|          | 2.8 | 130              | $0,006 \times d_1$ | $0,1 \times d_1$  | $0,05 \times d_1$ | 170                | $0,005 \times d_1$  |                          |                                     | <input type="checkbox"/>            | <input checked="" type="checkbox"/> |
|          | 3.1 |                  |                    |                   |                   |                    |                     |                          |                                     |                                     |                                     |
|          | 3.2 |                  |                    |                   |                   |                    |                     |                          |                                     |                                     |                                     |
| 4.1      |     |                  |                    |                   |                   |                    |                     |                          |                                     |                                     |                                     |
| 4.2      |     |                  |                    |                   |                   |                    |                     |                          |                                     |                                     |                                     |
| 4.3      |     |                  |                    |                   |                   |                    |                     |                          |                                     |                                     |                                     |
| 4.4      |     |                  |                    |                   |                   |                    |                     |                          |                                     |                                     |                                     |
| 5.1      |     |                  |                    |                   |                   |                    |                     |                          |                                     |                                     |                                     |
| 5.2      |     |                  |                    |                   |                   |                    |                     |                          |                                     |                                     |                                     |
| 5.3      |     |                  |                    |                   |                   |                    |                     |                          |                                     |                                     |                                     |
| <b>S</b> | 1.1 |                  |                    |                   |                   | 150                | $0,006 \times d_1$  |                          |                                     |                                     | <input checked="" type="checkbox"/> |
|          | 1.2 |                  |                    |                   |                   | 120                | $0,005 \times d_1$  |                          |                                     |                                     | <input checked="" type="checkbox"/> |
|          | 1.3 |                  |                    |                   |                   | 70                 | $0,005 \times d_1$  |                          |                                     |                                     | <input checked="" type="checkbox"/> |
|          | 2.1 |                  |                    |                   |                   | 110                | $0,006 \times d_1$  |                          |                                     |                                     | <input checked="" type="checkbox"/> |
|          | 2.2 |                  |                    |                   |                   | 50                 | $0,004 \times d_1$  |                          |                                     |                                     | <input checked="" type="checkbox"/> |
|          | 2.3 |                  |                    |                   |                   | 40                 | $0,004 \times d_1$  |                          |                                     |                                     | <input checked="" type="checkbox"/> |
|          | 2.4 |                  |                    |                   |                   | 40                 | $0,004 \times d_1$  |                          |                                     |                                     | <input checked="" type="checkbox"/> |
| 2.5      |     |                  |                    |                   | 30                | $0,003 \times d_1$ |                     |                          |                                     | <input checked="" type="checkbox"/> |                                     |
| 2.6      |     |                  |                    |                   | 40                | $0,003 \times d_1$ |                     |                          |                                     | <input checked="" type="checkbox"/> |                                     |
| <b>H</b> | 1.1 | 130              | $0,008 \times d_1$ | $0,05 \times d_1$ | $0,02 \times d_1$ | 180                | $0,006 \times d_1$  | <input type="checkbox"/> | <input checked="" type="checkbox"/> | <input type="checkbox"/>            | <input type="checkbox"/>            |
|          | 1.2 | 120              | $0,007 \times d_1$ | $0,05 \times d_1$ | $0,02 \times d_1$ | 160                | $0,005 \times d_1$  | <input type="checkbox"/> | <input checked="" type="checkbox"/> | <input type="checkbox"/>            | <input type="checkbox"/>            |
|          | 1.3 |                  |                    |                   |                   | 140                | $0,005 \times d_1$  | <input type="checkbox"/> | <input checked="" type="checkbox"/> | <input type="checkbox"/>            | <input type="checkbox"/>            |
|          | 1.4 |                  |                    |                   |                   | 110                | $0,004 \times d_1$  | <input type="checkbox"/> | <input checked="" type="checkbox"/> | <input type="checkbox"/>            | <input type="checkbox"/>            |
|          | 1.5 |                  |                    |                   |                   | 90                 | $0,003 \times d_1$  | <input type="checkbox"/> | <input checked="" type="checkbox"/> | <input type="checkbox"/>            | <input type="checkbox"/>            |

$v_c$  = Schnittgeschwindigkeit · Cutting speed  
 $f_z$  = Vorschub pro Zahn · Feed per tooth

= sehr gut geeignet · very suitable  
 = gut geeignet · suitable

- Multifunktionales Hochleistungswerkzeug
- Mit 220-240° Kugelschneide
- 4 Schneiden zur Mitte
- 2 Baulängen verfügbar

- Multi-functional, high performance tool
- With 220-240° ball nose
- 4 centre cutting edges
- 2 lengths available

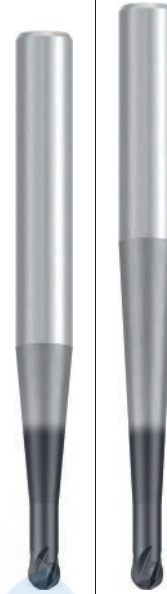
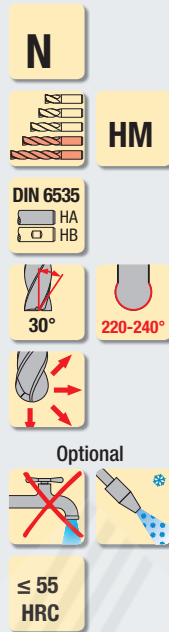

Allround

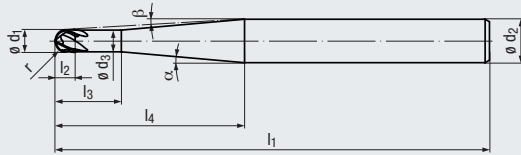

Beschichtung · Coating

ALCR

Einsatzgebiete – Material (siehe Seite 4)

- In vielen Werkstoffen einsetzbar
- Hinterschnittige Bearbeitung möglich
- Zum HSC-Schlichten von Turbinenschaufeln
- Speziell für schwer zerspanbare Werkstoffe geeignet

Applications – material (see page 4)

- For many materials
- Machining of undercuts
- Suitable for High-Speed finishing of turbine blades
- Especially suitable for difficult to cut materials

|   |         |
|---|---------|
| P | 1.1-5.1 |
| M | 1.1-4.1 |
| K | 1.1-4.2 |
| N | 2.1-2.8 |
| S | 1.1-2.6 |
| H | 1.1-1.3 |

Lange Ausführung · Long design

| Bestell-Code · Order code |        |       |       |       |                   |       |                   |          |         |          |              | 2564L |  |  |
|---------------------------|--------|-------|-------|-------|-------------------|-------|-------------------|----------|---------|----------|--------------|-------|--|--|
| $\varnothing d_1$         | r      | $l_2$ | $l_3$ | $l_1$ | $\varnothing d_3$ | $l_4$ | $\varnothing d_2$ | $\alpha$ | $\beta$ | Z        | Dimens.-Code |       |  |  |
| -0,04                     | -0,002 |       |       |       |                   |       | h5                |          |         | (Flutes) |              |       |  |  |
| 4                         | 2      | 3,3   | 10    | 90    | 3                 | 38,6  | 8                 | 5°       | 3,5°    | 4        | .04010B      | ●     |  |  |
| 6                         | 3      | 4,6   | 15    | 100   | 5                 | 43,6  | 10                | 5°       | 3°      | 4        | .06015B      | ●     |  |  |
| 8                         | 4      | 6,6   | 20    | 108   | 6                 | 54,3  | 12                | 5°       | 2,5°    | 4        | .08020B      | ●     |  |  |
| 10                        | 5      | 8,3   | 25    | 125   | 7,5               | 73,6  | 16                | 5°       | 2°      | 4        | .10025B      | ●     |  |  |

Extra lange Ausführung · Extra long design

| Bestell-Code · Order code |        |       |       |       |                   |       |                   |          |         |          |              | 2564L |  |  |
|---------------------------|--------|-------|-------|-------|-------------------|-------|-------------------|----------|---------|----------|--------------|-------|--|--|
| $\varnothing d_1$         | r      | $l_2$ | $l_3$ | $l_1$ | $\varnothing d_3$ | $l_4$ | $\varnothing d_2$ | $\alpha$ | $\beta$ | Z        | Dimens.-Code |       |  |  |
| -0,04                     | -0,002 |       |       |       |                   |       | h5                |          |         | (Flutes) |              |       |  |  |
| 4                         | 2      | 3,3   | 10    | 95    | 3                 | 57,7  | 8                 | 3°       | 2,5°    | 4        | .04010A      | ●     |  |  |
| 6                         | 3      | 4,6   | 15    | 105   | 5                 | 62,7  | 10                | 3°       | 2°      | 4        | .06015A      | ●     |  |  |
| 8                         | 4      | 6,6   | 20    | 125   | 6                 | 77,2  | 12                | 3°       | 2°      | 4        | .08020A      | ●     |  |  |
| 10                        | 5      | 8,3   | 25    | 160   | 7,5               | 106,1 | 16                | 3°       | 2°      | 4        | .10025A      | ●     |  |  |



Kugel auf bis zu 240° schneidend einsetzbar  
Ball nose with fully functional cutting edge up to 240°



**Hartmetall-Kugelfräser „Lollipop“ – lange Ausführung (4 Schneiden)**  
Solid carbide ball nose end mills “Lollipop” – long design (4 flutes)

**N**

Schlichten (4 Schneiden)  
Finishing (4 flutes)

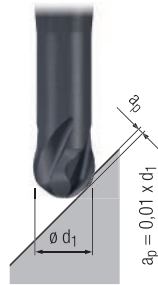

Gültig für · Valid for  
2564L



|          | $v_c$<br>[m/min] | $f_z$<br>[mm] |                |                          | MMS<br>MQL                          |                                     |                                     |
|----------|------------------|---------------|----------------|--------------------------|-------------------------------------|-------------------------------------|-------------------------------------|
| <b>P</b> | 1.1              | 280           | 0,008 x $d_1$  | <input type="checkbox"/> | <input checked="" type="checkbox"/> | <input type="checkbox"/>            | <input checked="" type="checkbox"/> |
|          | 2.1              | 260           | 0,008 x $d_1$  | <input type="checkbox"/> | <input checked="" type="checkbox"/> | <input type="checkbox"/>            | <input checked="" type="checkbox"/> |
|          | 3.1              | 240           | 0,007 x $d_1$  | <input type="checkbox"/> | <input checked="" type="checkbox"/> | <input type="checkbox"/>            | <input type="checkbox"/>            |
|          | 4.1              | 220           | 0,006 x $d_1$  | <input type="checkbox"/> | <input checked="" type="checkbox"/> | <input type="checkbox"/>            | <input type="checkbox"/>            |
|          | 5.1              | 180           | 0,0054 x $d_1$ | <input type="checkbox"/> | <input checked="" type="checkbox"/> | <input type="checkbox"/>            | <input type="checkbox"/>            |
| <b>M</b> | 1.1              | 130           | 0,006 x $d_1$  |                          | <input type="checkbox"/>            | <input checked="" type="checkbox"/> |                                     |
|          | 2.1              | 110           | 0,006 x $d_1$  |                          | <input type="checkbox"/>            | <input checked="" type="checkbox"/> |                                     |
|          | 3.1              | 80            | 0,005 x $d_1$  |                          | <input type="checkbox"/>            | <input checked="" type="checkbox"/> |                                     |
|          | 4.1              | 80            | 0,005 x $d_1$  |                          | <input type="checkbox"/>            | <input checked="" type="checkbox"/> |                                     |
| <b>K</b> | 1.1              | 280           | 0,008 x $d_1$  | <input type="checkbox"/> | <input checked="" type="checkbox"/> | <input type="checkbox"/>            |                                     |
|          | 1.2              | 260           | 0,008 x $d_1$  | <input type="checkbox"/> | <input checked="" type="checkbox"/> | <input type="checkbox"/>            |                                     |
|          | 2.1              | 240           | 0,006 x $d_1$  | <input type="checkbox"/> | <input checked="" type="checkbox"/> | <input type="checkbox"/>            |                                     |
|          | 2.2              | 220           | 0,006 x $d_1$  | <input type="checkbox"/> | <input checked="" type="checkbox"/> | <input type="checkbox"/>            |                                     |
|          | 3.1              | 200           | 0,006 x $d_1$  | <input type="checkbox"/> | <input checked="" type="checkbox"/> | <input type="checkbox"/>            |                                     |
|          | 3.2              | 200           | 0,006 x $d_1$  | <input type="checkbox"/> | <input checked="" type="checkbox"/> | <input type="checkbox"/>            |                                     |
|          | 4.1              | 180           | 0,005 x $d_1$  | <input type="checkbox"/> | <input checked="" type="checkbox"/> | <input type="checkbox"/>            |                                     |
|          | 4.2              | 150           | 0,005 x $d_1$  | <input type="checkbox"/> | <input checked="" type="checkbox"/> | <input type="checkbox"/>            |                                     |
| <b>N</b> | 1.1              |               |                |                          |                                     |                                     |                                     |
|          | 1.2              |               |                |                          |                                     |                                     |                                     |
|          | 1.3              |               |                |                          |                                     |                                     |                                     |
|          | 1.4              |               |                |                          |                                     |                                     |                                     |
|          | 1.5              |               |                |                          |                                     |                                     |                                     |
|          | 1.6              |               |                |                          |                                     |                                     |                                     |
|          | 2.1              | 260           | 0,008 x $d_1$  |                          |                                     | <input type="checkbox"/>            | <input checked="" type="checkbox"/> |
|          | 2.2              | 260           | 0,008 x $d_1$  |                          |                                     | <input type="checkbox"/>            | <input checked="" type="checkbox"/> |
|          | 2.3              | 260           | 0,008 x $d_1$  | <input type="checkbox"/> | <input type="checkbox"/>            | <input type="checkbox"/>            | <input checked="" type="checkbox"/> |
|          | 2.4              | 220           | 0,007 x $d_1$  |                          |                                     | <input type="checkbox"/>            | <input checked="" type="checkbox"/> |
|          | 2.5              | 220           | 0,007 x $d_1$  |                          |                                     | <input type="checkbox"/>            | <input checked="" type="checkbox"/> |
|          | 2.6              | 220           | 0,007 x $d_1$  | <input type="checkbox"/> | <input type="checkbox"/>            | <input type="checkbox"/>            | <input checked="" type="checkbox"/> |
|          | 2.7              | 130           | 0,006 x $d_1$  |                          |                                     | <input type="checkbox"/>            | <input checked="" type="checkbox"/> |
|          | 2.8              | 130           | 0,005 x $d_1$  |                          |                                     | <input type="checkbox"/>            | <input checked="" type="checkbox"/> |
|          | 3.1              |               |                |                          |                                     |                                     |                                     |
|          | 3.2              |               |                |                          |                                     |                                     |                                     |
| 4.1      |                  |               |                |                          |                                     |                                     |                                     |
| 4.2      |                  |               |                |                          |                                     |                                     |                                     |
| 4.3      |                  |               |                |                          |                                     |                                     |                                     |
| 4.4      |                  |               |                |                          |                                     |                                     |                                     |
| 5.1      |                  |               |                |                          |                                     |                                     |                                     |
| 5.2      |                  |               |                |                          |                                     |                                     |                                     |
| 5.3      |                  |               |                |                          |                                     |                                     |                                     |
| <b>S</b> | 1.1              | 150           | 0,006 x $d_1$  |                          |                                     | <input checked="" type="checkbox"/> |                                     |
|          | 1.2              | 120           | 0,005 x $d_1$  |                          |                                     | <input checked="" type="checkbox"/> |                                     |
|          | 1.3              | 70            | 0,005 x $d_1$  |                          |                                     | <input checked="" type="checkbox"/> |                                     |
|          | 2.1              | 110           | 0,006 x $d_1$  |                          |                                     | <input checked="" type="checkbox"/> |                                     |
|          | 2.2              | 50            | 0,004 x $d_1$  |                          |                                     | <input checked="" type="checkbox"/> |                                     |
|          | 2.3              | 40            | 0,004 x $d_1$  |                          |                                     | <input checked="" type="checkbox"/> |                                     |
|          | 2.4              | 40            | 0,004 x $d_1$  |                          |                                     | <input checked="" type="checkbox"/> |                                     |
| 2.5      | 30               | 0,003 x $d_1$ |                |                          | <input checked="" type="checkbox"/> |                                     |                                     |
| 2.6      | 40               | 0,003 x $d_1$ |                |                          | <input checked="" type="checkbox"/> |                                     |                                     |
| <b>H</b> | 1.1              | 160           | 0,006 x $d_1$  | <input type="checkbox"/> | <input checked="" type="checkbox"/> | <input type="checkbox"/>            |                                     |
|          | 1.2              | 140           | 0,005 x $d_1$  | <input type="checkbox"/> | <input checked="" type="checkbox"/> | <input type="checkbox"/>            |                                     |
|          | 1.3              | 120           | 0,005 x $d_1$  | <input type="checkbox"/> | <input checked="" type="checkbox"/> | <input type="checkbox"/>            |                                     |
|          | 1.4              |               |                |                          |                                     |                                     |                                     |
|          | 1.5              |               |                |                          |                                     |                                     |                                     |

$v_c$  = Schnittgeschwindigkeit · Cutting speed  
 $f_z$  = Vorschub pro Zahn · Feed per tooth

= sehr gut geeignet · very suitable  
 = gut geeignet · suitable

- Hochleistungswerkzeug
- Mit 3 und 4 Schneiden
- Schruppverzahnung
- Ungleiche Teilung
- Vibrationsarme Bearbeitung
- Konuswinkel 3°

- High performance tool
- With 3 and 4 flutes
- Roughing profile
- Variable spacing
- Low-vibration machining
- Taper angle 3°

**NR** 

**ICA**

**HM** 

**DIN 6535**  
HA  
HB 

**45°** 

**Torus** 

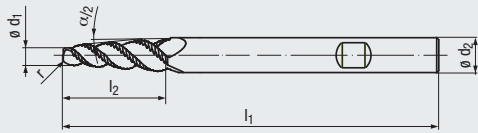

Design I<sub>4</sub>:

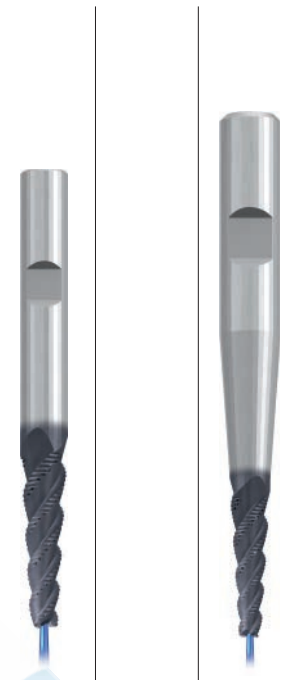
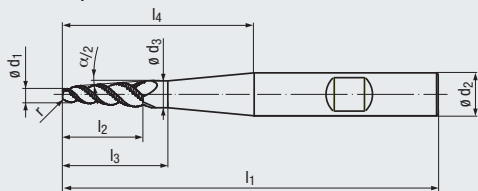

Allround

Allround

**Beschichtung · Coating**

**ALCR**

**ALCR**

**Einsatzgebiete – Material (siehe Seite 4)**

- Speziell für hochfeste Werkstoffe geeignet
- Auch für Nickel-Basis-Legierungen einsetzbar
- Für die Zerspaltung von Titan-Legierungen geeignet
- Einsatz in allen Turbinenwerkstoffen möglich
- Optimiert zur Bearbeitung von Impellern und Integrated Bladed Rotors (IBR) aus Aluminium, Titan und Inconel

**Applications – material (see page 4)**

- Especially suitable for high-strength materials
- Also suitable in nickel-base alloys
- For the machining of titanium alloys
- Suitable in all turbine materials
- Optimised for machining Impellers and Integrated Bladed Rotors (IBR) made from aluminium, titanium and Inconel

|          |                |          |                |
|----------|----------------|----------|----------------|
| <b>P</b> | <b>1.1-5.1</b> | <b>P</b> | <b>1.1-5.1</b> |
| <b>M</b> | <b>1.1-4.1</b> | <b>M</b> | <b>1.1-4.1</b> |
| <b>N</b> | <b>1.1-1.3</b> | <b>N</b> | <b>1.1-1.3</b> |
| <b>S</b> | <b>1.1-1.3</b> | <b>S</b> | <b>1.1-1.3</b> |
| <b>S</b> | <b>2.2-2.6</b> | <b>S</b> | <b>2.2-2.6</b> |

**Kurze Ausführung · Short design**

**Bestell-Code · Order code**

**3534LZ**

| $\alpha/2$ | $\varnothing d_1$<br>-0,05 | r | $l_2$ | $l_3$ | $l_1$ | $l_4$ | $\varnothing d_3$ | $\varnothing d_2$<br>h6 | Z<br>(Flutes) | Dimens.-<br>Code |
|------------|----------------------------|---|-------|-------|-------|-------|-------------------|-------------------------|---------------|------------------|
| <b>3°</b>  | <b>6,5</b>                 | 1 | 14    | –     | 68    | –     | –                 | 8                       | <b>4</b>      | <b>.03065A</b>   |
|            | <b>7,5</b>                 | 1 | 23,5  | –     | 80    | –     | –                 | 10                      | <b>4</b>      | <b>.03075A</b>   |
|            | <b>8,5</b>                 | 1 | 33    | –     | 93    | –     | –                 | 12                      | <b>4</b>      | <b>.03085A</b>   |

**Lange Ausführung · Long design**

**Bestell-Code · Order code**

**3532LZ**

| $\alpha/2$ | $\varnothing d_1$<br>-0,05 | r | $l_2$ | $l_3$ | $l_1$ | $l_4$ | $\varnothing d_3$ | $\varnothing d_2$<br>h6 | Z<br>(Flutes) | Dimens.-<br>Code |
|------------|----------------------------|---|-------|-------|-------|-------|-------------------|-------------------------|---------------|------------------|
| <b>3°</b>  | <b>5</b>                   | 1 | 20    | 29,5  | 80    | 38    | 7,1               | 8                       | <b>3</b>      | <b>.03050A</b>   |
|            | <b>5,5</b>                 | 1 | 25    | 34,5  | 95    | 52,5  | 8,1               | 10                      | <b>3</b>      | <b>.03055A</b>   |
|            | <b>6</b>                   | 1 | 30    | 39,5  | 120   | 67    | 9,1               | 12                      | <b>3</b>      | <b>.03060A</b>   |



**Konische Hartmetall-Torusräser**  
Tapered solid carbide torus end mills

NR

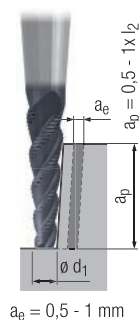
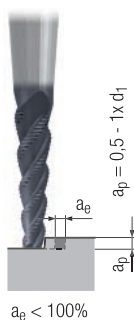

**Gültig für · Valid for**  
3532LZ  
3534LZ

Für die Berechnung der Drehzahl n muss mit dem mittleren Durchmesser  $d_m$  (Messpunkt bei  $0,5 \times a_p$ ) gerechnet werden.

For the calculation of rpm (n), use the average diameter  $d_m$  (measuring point at  $0.5 \times a_p$ ).

$$n = \frac{v_c \times 1000}{d_m \times \pi} \text{ [min}^{-1}\text{]}$$



|          | $v_c$<br>[m/min] | $f_z$<br>[mm] | $v_c$<br>[m/min]   | $f_z$<br>[mm] |                    |  |   |   |   |
|----------|------------------|---------------|--------------------|---------------|--------------------|--|---|---|---|
| <b>P</b> | 1.1              | 100           | $0,005 \times d_1$ | 140           | $0,005 \times d_1$ |  | ■ | □ | ■ |
|          | 2.1              | 90            | $0,004 \times d_1$ | 130           | $0,004 \times d_1$ |  | ■ | □ | ■ |
|          | 3.1              | 90            | $0,004 \times d_1$ | 120           | $0,004 \times d_1$ |  | ■ | □ | ■ |
|          | 4.1              | 80            | $0,003 \times d_1$ | 110           | $0,003 \times d_1$ |  | ■ | □ | ■ |
|          | 5.1              | 70            | $0,003 \times d_1$ | 100           | $0,003 \times d_1$ |  | ■ | □ | ■ |
| <b>M</b> | 1.1              | 100           | $0,004 \times d_1$ | 110           | $0,004 \times d_1$ |  |   |   | ■ |
|          | 2.1              | 80            | $0,003 \times d_1$ | 90            | $0,003 \times d_1$ |  |   |   | ■ |
|          | 3.1              | 60            | $0,002 \times d_1$ | 80            | $0,002 \times d_1$ |  |   |   | ■ |
|          | 4.1              | 50            | $0,002 \times d_1$ | 60            | $0,002 \times d_1$ |  |   |   | ■ |
| <b>K</b> | 1.1              |               |                    |               |                    |  |   |   |   |
|          | 1.2              |               |                    |               |                    |  |   |   |   |
|          | 2.1              |               |                    |               |                    |  |   |   |   |
|          | 2.2              |               |                    |               |                    |  |   |   |   |
|          | 3.1              |               |                    |               |                    |  |   |   |   |
|          | 3.2              |               |                    |               |                    |  |   |   |   |
|          | 4.1              |               |                    |               |                    |  |   |   |   |
| <b>N</b> | 1.1              | 280           | $0,006 \times d_1$ | 400           | $0,006 \times d_1$ |  |   |   | ■ |
|          | 1.2              | 200           | $0,005 \times d_1$ | 280           | $0,005 \times d_1$ |  |   |   | ■ |
|          | 1.3              | 140           | $0,004 \times d_1$ | 200           | $0,004 \times d_1$ |  |   |   | ■ |
|          | 1.4              |               |                    |               |                    |  |   |   |   |
|          | 1.5              |               |                    |               |                    |  |   |   |   |
|          | 1.6              |               |                    |               |                    |  |   |   |   |
|          | 2.1              |               |                    |               |                    |  |   |   |   |
|          | 2.2              |               |                    |               |                    |  |   |   |   |
|          | 2.3              |               |                    |               |                    |  |   |   |   |
|          | 2.4              |               |                    |               |                    |  |   |   |   |
|          | 2.5              |               |                    |               |                    |  |   |   |   |
|          | 2.6              |               |                    |               |                    |  |   |   |   |
|          | 2.7              |               |                    |               |                    |  |   |   |   |
|          | 2.8              |               |                    |               |                    |  |   |   |   |
|          | 3.1              |               |                    |               |                    |  |   |   |   |
| 3.2      |                  |               |                    |               |                    |  |   |   |   |
| 4.1      |                  |               |                    |               |                    |  |   |   |   |
| 4.2      |                  |               |                    |               |                    |  |   |   |   |
| 4.3      |                  |               |                    |               |                    |  |   |   |   |
| 4.4      |                  |               |                    |               |                    |  |   |   |   |
| 5.1      |                  |               |                    |               |                    |  |   |   |   |
| 5.2      |                  |               |                    |               |                    |  |   |   |   |
| 5.3      |                  |               |                    |               |                    |  |   |   |   |
| <b>S</b> | 1.1              | 90            | $0,002 \times d_1$ | 120           | $0,002 \times d_1$ |  |   |   | ■ |
|          | 1.2              | 75            | $0,002 \times d_1$ | 100           | $0,002 \times d_1$ |  |   |   | ■ |
|          | 1.3              | 45            | $0,002 \times d_1$ | 60            | $0,002 \times d_1$ |  |   |   | ■ |
|          | 2.1              |               |                    |               |                    |  |   |   |   |
|          | 2.2              | 25            | $0,002 \times d_1$ | 30            | $0,002 \times d_1$ |  |   |   | ■ |
|          | 2.3              | 25            | $0,002 \times d_1$ | 30            | $0,002 \times d_1$ |  |   |   | ■ |
|          | 2.4              | 25            | $0,002 \times d_1$ | 30            | $0,002 \times d_1$ |  |   |   | ■ |
|          | 2.5              | 15            | $0,002 \times d_1$ | 20            | $0,002 \times d_1$ |  |   |   | ■ |
|          | 2.6              | 25            | $0,002 \times d_1$ | 30            | $0,002 \times d_1$ |  |   |   | ■ |
|          | <b>H</b>         | 1.1           |                    |               |                    |  |   |   |   |
| 1.2      |                  |               |                    |               |                    |  |   |   |   |
| 1.3      |                  |               |                    |               |                    |  |   |   |   |
| 1.4      |                  |               |                    |               |                    |  |   |   |   |
| 1.5      |                  |               |                    |               |                    |  |   |   |   |

$v_c$  = Schnittgeschwindigkeit · Cutting speed  
 $f_z$  = Vorschub pro Zahn · Feed per tooth

■ = sehr gut geeignet · very suitable  
□ = gut geeignet · suitable

- Multifunktionales Werkzeug
- Mit 2 Schneiden
- Verschiedene Kegelwinkel
- Auch mit poliertem Spanraum erhältlich
- Multi-functional tool
- With 2 flutes
- Various taper angles
- Also available with polished chip space

**N**

**HM**

DIN 6535

HA  
HB

30°

Torus

Optional

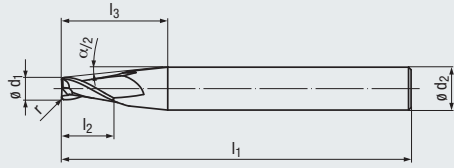

Design I<sub>4</sub>:

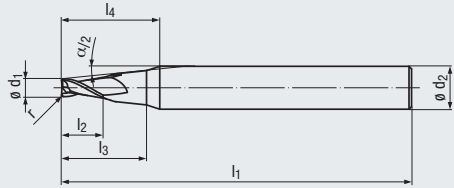

Mit poliertem Spanraum  
With polished chip space

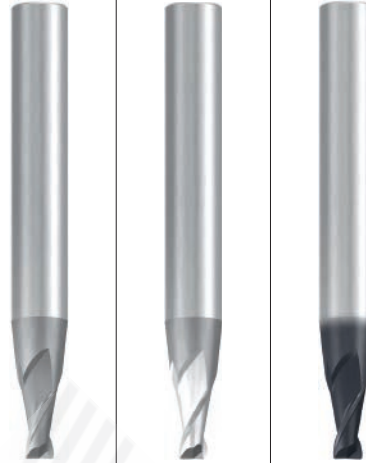

Allround

Allround

Beschichtung · Coating

Einsatzgebiete – Material (siehe Seite 4)

- In fast allen Werkstoffen einsetzbar
- Zum Schruppen geeignet

Applications – material (see page 4)

- For almost all materials
- Suitable for roughing

**ALCR**

N 1.1-1.3

N 4.1-4.2

P 1.1-3.1 4.1-5.1

M 1.1-2.1

K 1.1-2.2 3.1-4.2

N 1.1-1.4 1.5

N 2.1-2.6 2.7-2.8

N 3.1-4.4, 5.2-5.3

S 1.1-1.2 1.3

S 2.1-2.2 2.3-2.6

Bestell-Code · Order code

| $\alpha/2$ | $\varnothing d_1$ | r<br>$\pm 0,01$ | $l_2$ | $l_3$ | $l_1$ | $l_4$ | $\varnothing d_2$<br>h6 | Z<br>(Flutes) | Dimens.-<br>Code | 3444 | 3445 | 3444L |
|------------|-------------------|-----------------|-------|-------|-------|-------|-------------------------|---------------|------------------|------|------|-------|
| 3°         | 3                 | 0,3             | 6     | 24    | 63    | 26    | 8                       | 2             | .03003A          | ●    | ●    | ●     |
|            | 4                 | 0,4             | 8     | 24    | 63    | 26    | 8                       | 2             | .03004A          | ●    | ●    | ●     |
|            | 5                 | 0,5             | 10    | 25    | 63    | 26    | 8                       | 2             | .03005A          | ●    | ●    | ●     |
| 4°         | 3                 | 0,3             | 6     | 24    | 63    | 26    | 8                       | 2             | .04003A          | ●    | ●    | ●     |
|            | 4                 | 0,4             | 8     | 25    | 63    | 26    | 8                       | 2             | .04004A          | ●    | ●    | ●     |
|            | 5                 | 0,5             | 10    | 23    | 63    | —     | 8                       | 2             | .04005A          | ●    | ●    | ●     |
| 6°         | 3                 | 0,3             | 6     | 25    | 63    | —     | 8                       | 2             | .06003A          | ●    | ●    | ●     |
|            | 4                 | 0,4             | 8     | 20    | 63    | —     | 8                       | 2             | .06004A          | ●    | ●    | ●     |
|            | 5                 | 0,5             | 10    | 25    | 80    | —     | 10                      | 2             | .06005A          | ●    | ●    | ●     |
| 8°         | 3                 | 0,3             | 6     | 25    | 80    | —     | 10                      | 2             | .08003A          | ●    | ●    | ●     |
|            | 4                 | 0,4             | 8     | 22    | 80    | —     | 10                      | 2             | .08004A          | ●    | ●    | ●     |
|            | 5                 | 0,5             | 10    | 25    | 83    | —     | 12                      | 2             | .08005A          | ●    | ●    | ●     |

**Konische Hartmetall-Torusfräser**  
Tapered solid carbide torus end mills

**N**

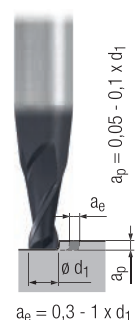
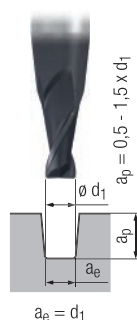
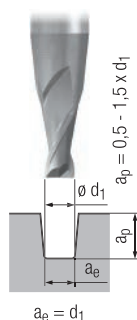

**Gültig für** · Valid for  
3444 3444L 3445

Für die Berechnung der Drehzahl n muss mit dem mittleren Durchmesser  $d_m$  (Messpunkt bei  $0,5 \times a_p$ ) gerechnet werden.

For the calculation of rpm (n), use the average diameter  $d_m$  (measuring point at  $0,5 \times a_p$ ).

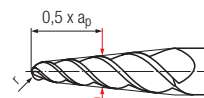

$$n = \frac{v_c \times 1000}{d_m \times \pi} \text{ [min}^{-1}\text{]}$$

Unbeschichtet · Uncoated

ALCR



|          | Unbeschichtet · Uncoated |               |                    |                    | ALCR               |               |                    |                    |                                     |                                     |                          |                                     |                                     |
|----------|--------------------------|---------------|--------------------|--------------------|--------------------|---------------|--------------------|--------------------|-------------------------------------|-------------------------------------|--------------------------|-------------------------------------|-------------------------------------|
|          | $v_c$<br>[m/min]         | $f_z$<br>[mm] | $v_c$<br>[m/min]   | $f_z$<br>[mm]      | $v_c$<br>[m/min]   | $f_z$<br>[mm] | $v_c$<br>[m/min]   | $f_z$<br>[mm]      |                                     |                                     |                          |                                     |                                     |
| <b>P</b> | 1.1                      |               |                    |                    |                    |               | 220                | $0,010 \times d_1$ | <input type="checkbox"/>            | <input checked="" type="checkbox"/> | <input type="checkbox"/> | <input checked="" type="checkbox"/> |                                     |
|          | 2.1                      |               |                    |                    |                    |               | 200                | $0,009 \times d_1$ | <input type="checkbox"/>            | <input checked="" type="checkbox"/> | <input type="checkbox"/> | <input checked="" type="checkbox"/> |                                     |
|          | 3.1                      |               |                    |                    |                    |               | 160                | $0,008 \times d_1$ | <input type="checkbox"/>            | <input checked="" type="checkbox"/> | <input type="checkbox"/> | <input checked="" type="checkbox"/> |                                     |
|          | 4.1                      |               |                    |                    |                    |               | 130                | $0,007 \times d_1$ | <input type="checkbox"/>            | <input checked="" type="checkbox"/> | <input type="checkbox"/> | <input checked="" type="checkbox"/> |                                     |
|          | 5.1                      |               |                    |                    |                    |               | 110                | $0,006 \times d_1$ | <input type="checkbox"/>            | <input checked="" type="checkbox"/> | <input type="checkbox"/> | <input checked="" type="checkbox"/> |                                     |
| <b>M</b> | 1.1                      |               |                    |                    |                    |               | 110                | $0,006 \times d_1$ |                                     |                                     | <input type="checkbox"/> | <input checked="" type="checkbox"/> |                                     |
|          | 2.1                      |               |                    |                    |                    |               | 90                 | $0,006 \times d_1$ |                                     |                                     | <input type="checkbox"/> | <input checked="" type="checkbox"/> |                                     |
|          | 3.1                      |               |                    |                    |                    |               |                    |                    |                                     |                                     | <input type="checkbox"/> | <input checked="" type="checkbox"/> |                                     |
|          | 4.1                      |               |                    |                    |                    |               |                    |                    |                                     |                                     | <input type="checkbox"/> | <input checked="" type="checkbox"/> |                                     |
| <b>K</b> | 1.1                      |               |                    |                    |                    |               | 220                | $0,010 \times d_1$ | <input checked="" type="checkbox"/> | <input checked="" type="checkbox"/> | <input type="checkbox"/> | <input type="checkbox"/>            |                                     |
|          | 1.2                      |               |                    |                    |                    |               | 220                | $0,010 \times d_1$ | <input checked="" type="checkbox"/> | <input checked="" type="checkbox"/> | <input type="checkbox"/> | <input type="checkbox"/>            |                                     |
|          | 2.1                      |               |                    |                    |                    |               | 190                | $0,008 \times d_1$ | <input checked="" type="checkbox"/> | <input checked="" type="checkbox"/> | <input type="checkbox"/> | <input type="checkbox"/>            |                                     |
|          | 2.2                      |               |                    |                    |                    |               | 190                | $0,008 \times d_1$ | <input checked="" type="checkbox"/> | <input checked="" type="checkbox"/> | <input type="checkbox"/> | <input type="checkbox"/>            |                                     |
|          | 3.1                      |               |                    |                    |                    |               | 160                | $0,008 \times d_1$ | <input checked="" type="checkbox"/> | <input checked="" type="checkbox"/> | <input type="checkbox"/> | <input type="checkbox"/>            |                                     |
|          | 3.2                      |               |                    |                    |                    |               | 160                | $0,008 \times d_1$ | <input checked="" type="checkbox"/> | <input checked="" type="checkbox"/> | <input type="checkbox"/> | <input type="checkbox"/>            |                                     |
|          | 4.1                      |               |                    |                    |                    |               | 130                | $0,006 \times d_1$ | <input checked="" type="checkbox"/> | <input checked="" type="checkbox"/> | <input type="checkbox"/> | <input type="checkbox"/>            |                                     |
|          | 4.2                      |               |                    |                    |                    |               | 110                | $0,006 \times d_1$ | <input checked="" type="checkbox"/> | <input checked="" type="checkbox"/> | <input type="checkbox"/> | <input type="checkbox"/>            |                                     |
| <b>N</b> | 1.1                      | 280           | $0,010 \times d_1$ | 350                | $0,016 \times d_1$ | 400           | $0,010 \times d_1$ | 500                | $0,016 \times d_1$                  |                                     |                          | <input type="checkbox"/>            | <input checked="" type="checkbox"/> |
|          | 1.2                      | 280           | $0,008 \times d_1$ | 350                | $0,014 \times d_1$ | 400           | $0,008 \times d_1$ | 500                | $0,014 \times d_1$                  |                                     |                          | <input type="checkbox"/>            | <input checked="" type="checkbox"/> |
|          | 1.3                      | 250           | $0,006 \times d_1$ | 350                | $0,012 \times d_1$ | 350           | $0,006 \times d_1$ | 500                | $0,012 \times d_1$                  |                                     |                          | <input type="checkbox"/>            | <input checked="" type="checkbox"/> |
|          | 1.4                      |               |                    |                    |                    |               |                    | 380                | $0,014 \times d_1$                  |                                     |                          | <input type="checkbox"/>            | <input checked="" type="checkbox"/> |
|          | 1.5                      |               |                    |                    |                    |               |                    | 340                | $0,012 \times d_1$                  |                                     |                          | <input type="checkbox"/>            | <input checked="" type="checkbox"/> |
|          | 1.6                      |               |                    |                    |                    |               |                    |                    |                                     |                                     |                          | <input type="checkbox"/>            | <input checked="" type="checkbox"/> |
|          | 2.1                      |               |                    |                    |                    |               |                    | 200                | $0,010 \times d_1$                  |                                     |                          | <input type="checkbox"/>            | <input checked="" type="checkbox"/> |
|          | 2.2                      |               |                    |                    |                    |               |                    | 200                | $0,010 \times d_1$                  |                                     |                          | <input type="checkbox"/>            | <input checked="" type="checkbox"/> |
|          | 2.3                      |               |                    |                    |                    |               |                    | 200                | $0,010 \times d_1$                  | <input type="checkbox"/>            | <input type="checkbox"/> | <input type="checkbox"/>            | <input checked="" type="checkbox"/> |
|          | 2.4                      |               |                    |                    |                    |               |                    | 160                | $0,008 \times d_1$                  |                                     |                          | <input type="checkbox"/>            | <input checked="" type="checkbox"/> |
|          | 2.5                      |               |                    |                    |                    |               |                    | 160                | $0,008 \times d_1$                  |                                     |                          | <input type="checkbox"/>            | <input checked="" type="checkbox"/> |
|          | 2.6                      |               |                    |                    |                    |               |                    | 160                | $0,008 \times d_1$                  | <input type="checkbox"/>            | <input type="checkbox"/> | <input type="checkbox"/>            | <input checked="" type="checkbox"/> |
|          | 2.7                      |               |                    |                    |                    |               |                    | 100                | $0,006 \times d_1$                  |                                     |                          | <input type="checkbox"/>            | <input checked="" type="checkbox"/> |
|          | 2.8                      |               |                    |                    |                    |               |                    | 100                | $0,006 \times d_1$                  |                                     |                          | <input type="checkbox"/>            | <input checked="" type="checkbox"/> |
|          | 3.1                      |               |                    |                    |                    |               |                    | 450                | $0,018 \times d_1$                  |                                     |                          | <input type="checkbox"/>            | <input checked="" type="checkbox"/> |
|          | 3.2                      |               |                    |                    |                    |               |                    | 450                | $0,014 \times d_1$                  |                                     |                          | <input type="checkbox"/>            | <input checked="" type="checkbox"/> |
| 4.1      |                          |               | 220                | $0,015 \times d_1$ |                    |               | 320                | $0,015 \times d_1$ |                                     | <input type="checkbox"/>            | <input type="checkbox"/> | <input checked="" type="checkbox"/> |                                     |
| 4.2      |                          |               | 350                | $0,015 \times d_1$ |                    |               | 500                | $0,015 \times d_1$ |                                     | <input type="checkbox"/>            | <input type="checkbox"/> | <input checked="" type="checkbox"/> |                                     |
| 4.3      |                          |               |                    |                    |                    |               | 200                | $0,012 \times d_1$ |                                     | <input type="checkbox"/>            | <input type="checkbox"/> | <input checked="" type="checkbox"/> |                                     |
| 4.4      |                          |               |                    |                    |                    |               | 140                | $0,012 \times d_1$ |                                     | <input type="checkbox"/>            | <input type="checkbox"/> | <input checked="" type="checkbox"/> |                                     |
| 5.1      |                          |               |                    |                    |                    |               |                    |                    |                                     |                                     | <input type="checkbox"/> | <input checked="" type="checkbox"/> |                                     |
| 5.2      |                          |               |                    |                    |                    |               | 120                | $0,006 \times d_1$ |                                     |                                     | <input type="checkbox"/> | <input checked="" type="checkbox"/> |                                     |
| 5.3      |                          |               |                    |                    |                    |               | 220                | $0,012 \times d_1$ | <input type="checkbox"/>            | <input checked="" type="checkbox"/> | <input type="checkbox"/> | <input checked="" type="checkbox"/> |                                     |
| <b>S</b> | 1.1                      |               |                    |                    |                    | 50            | $0,004 \times d_1$ | 110                | $0,007 \times d_1$                  |                                     |                          | <input type="checkbox"/>            | <input checked="" type="checkbox"/> |
|          | 1.2                      |               |                    |                    |                    | 40            | $0,003 \times d_1$ | 90                 | $0,006 \times d_1$                  |                                     |                          | <input type="checkbox"/>            | <input checked="" type="checkbox"/> |
|          | 1.3                      |               |                    |                    |                    | 30            | $0,003 \times d_1$ | 50                 | $0,005 \times d_1$                  |                                     |                          | <input type="checkbox"/>            | <input checked="" type="checkbox"/> |
|          | 2.1                      |               |                    |                    |                    |               |                    | 80                 | $0,006 \times d_1$                  |                                     |                          | <input type="checkbox"/>            | <input checked="" type="checkbox"/> |
|          | 2.2                      |               |                    |                    |                    |               |                    | 30                 | $0,004 \times d_1$                  |                                     |                          | <input type="checkbox"/>            | <input checked="" type="checkbox"/> |
|          | 2.3                      |               |                    |                    |                    |               |                    | 30                 | $0,004 \times d_1$                  |                                     |                          | <input type="checkbox"/>            | <input checked="" type="checkbox"/> |
| 2.4      |                          |               |                    |                    |                    |               | 30                 | $0,004 \times d_1$ |                                     |                                     | <input type="checkbox"/> | <input checked="" type="checkbox"/> |                                     |
| 2.5      |                          |               |                    |                    |                    |               | 20                 | $0,004 \times d_1$ |                                     |                                     | <input type="checkbox"/> | <input checked="" type="checkbox"/> |                                     |
| 2.6      |                          |               |                    |                    |                    |               | 30                 | $0,004 \times d_1$ |                                     |                                     | <input type="checkbox"/> | <input checked="" type="checkbox"/> |                                     |
| <b>H</b> | 1.1                      |               |                    |                    |                    |               |                    |                    |                                     |                                     |                          | <input type="checkbox"/>            | <input checked="" type="checkbox"/> |
|          | 1.2                      |               |                    |                    |                    |               |                    |                    |                                     |                                     |                          | <input type="checkbox"/>            | <input checked="" type="checkbox"/> |
|          | 1.3                      |               |                    |                    |                    |               |                    |                    |                                     |                                     |                          | <input type="checkbox"/>            | <input checked="" type="checkbox"/> |
|          | 1.4                      |               |                    |                    |                    |               |                    |                    |                                     |                                     |                          | <input type="checkbox"/>            | <input checked="" type="checkbox"/> |
|          | 1.5                      |               |                    |                    |                    |               |                    |                    |                                     |                                     |                          | <input type="checkbox"/>            | <input checked="" type="checkbox"/> |

$v_c$  = Schnittgeschwindigkeit · Cutting speed  
 $f_z$  = Vorschub pro Zahn · Feed per tooth

= sehr gut geeignet · very suitable  
 = gut geeignet · suitable

- Hochleistungswerkzeug
- Mit 5-13 Schneiden
- Ungleiche Teilung
- Vibrationsarme Bearbeitung
- Innere Kühlschmierstoff-Zufuhr, Austritt axial (ICA)

- High performance tool
- With 5-13 flutes
- Variable spacing
- Low-vibration machining
- Internal coolant supply, axial exit (ICA)

N

ICA



HM



20°

Torus



Optional

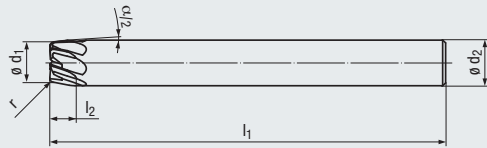

Allround



Allround

Beschichtung · Coating

TIALN

TIALN

Einsatzgebiete – Material (siehe Seite 4)

- Speziell für hochfeste Werkstoffe geeignet
- Auch für Nickel-Basis-Legierungen einsetzbar
- Für die Zerspanung von Titan-Legierungen geeignet
- Einsatz in allen Turbinenwerkstoffen möglich

Applications – material (see page 4)

- Especially suitable for high-strength materials
- Also suitable in nickel-base alloys
- For the machining of titanium alloys
- Suitable in all turbine materials

|   |         |   |         |
|---|---------|---|---------|
| P | 1.1-5.1 | P | 1.1-5.1 |
| M | 1.1-4.1 | M | 1.1-4.1 |
| K | 1.1-4.2 | K | 1.1-4.2 |
| N | 2.1-2.8 | N | 2.1-2.8 |
| S | 1.1-2.6 | S | 1.1-2.6 |

Lange Ausführung · Long design

Bestell-Code · Order code

2677AZ

| $\alpha/2$ | $\emptyset d_1$ | r<br>$\pm 0,01$ | $l_2$ | $l_1$ | $\emptyset d_2$<br>h6 | Z<br>(Flutes) | Dimens.-<br>Code |   |  |  |
|------------|-----------------|-----------------|-------|-------|-----------------------|---------------|------------------|---|--|--|
| 8°         | 8               | 0,8             | 7,5   | 80    | 10                    | 7             | .008008          | ● |  |  |
|            | 9               | 1               | 3,5   | 80    | 10                    | 7             | .009010          | ● |  |  |
|            | 10              | 1               | 7,5   | 80    | 12                    | 9             | .010010          | ● |  |  |
|            | 11              | 1               | 3,5   | 80    | 12                    | 9             | .011010          | ● |  |  |

Extra lange Ausführung · Extra long design

Bestell-Code · Order code

2678AZ

| $\alpha/2$ | $\emptyset d_1$ | r<br>$\pm 0,01$ | $l_2$ | $l_1$ | $\emptyset d_2$<br>h6 | Z<br>(Flutes) | Dimens.-<br>Code |  |   |  |
|------------|-----------------|-----------------|-------|-------|-----------------------|---------------|------------------|--|---|--|
| 8°         | 9               | 1               | 3,5   | 108   | 10                    | 5             | .009010          |  | ● |  |
|            | 10              | 1               | 7,5   | 108   | 12                    | 7             | .010010          |  | ● |  |
|            | 11              | 1               | 3,5   | 108   | 12                    | 7             | .011010          |  | ● |  |
|            | 15              | 1               | 3,5   | 108   | 16                    | 9             | .015010          |  | ● |  |
|            | 15              | 1               | 3,5   | 108   | 16                    | 13            | .115010          |  | ● |  |
|            | 19              | 1               | 3,5   | 108   | 20                    | 9             | .019010          |  | ● |  |
|            | 19              | 1               | 3,5   | 108   | 20                    | 13            | .119010          |  | ● |  |



**Konische Hartmetall-Torusfräser – lange und extra lange Ausführung**  
 Tapered solid carbide torus end mills – long and extra long design

Gültig für · Valid for  
 2677AZ 2678AZ



**N**

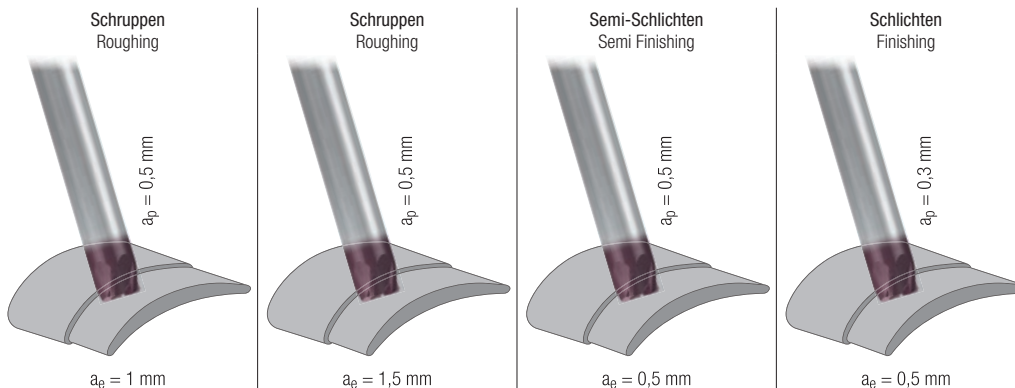

|          |     | Schruppen Roughing |                    | Semi-Schlichten Semi Finishing |                    | Schlichten Finishing |                    |                    |                    |                          |                                     |                                     |                                     |
|----------|-----|--------------------|--------------------|--------------------------------|--------------------|----------------------|--------------------|--------------------|--------------------|--------------------------|-------------------------------------|-------------------------------------|-------------------------------------|
|          |     | $V_c$ [m/min]      | $f_z$ [mm]         | $V_c$ [m/min]                  | $f_z$ [mm]         | $V_c$ [m/min]        | $f_z$ [mm]         |                    |                    |                          |                                     |                                     |                                     |
| <b>P</b> | 1.1 | 160                | $0,005 \times d_1$ | 140                            | $0,004 \times d_1$ | 180                  | $0,008 \times d_1$ | 200                | $0,006 \times d_1$ | <input type="checkbox"/> | <input checked="" type="checkbox"/> | <input type="checkbox"/>            | <input checked="" type="checkbox"/> |
|          | 2.1 | 150                | $0,005 \times d_1$ | 130                            | $0,004 \times d_1$ | 170                  | $0,007 \times d_1$ | 190                | $0,005 \times d_1$ | <input type="checkbox"/> | <input checked="" type="checkbox"/> | <input type="checkbox"/>            | <input checked="" type="checkbox"/> |
|          | 3.1 | 140                | $0,004 \times d_1$ | 120                            | $0,003 \times d_1$ | 160                  | $0,006 \times d_1$ | 180                | $0,005 \times d_1$ | <input type="checkbox"/> | <input checked="" type="checkbox"/> | <input type="checkbox"/>            | <input checked="" type="checkbox"/> |
|          | 4.1 | 130                | $0,004 \times d_1$ | 110                            | $0,003 \times d_1$ | 150                  | $0,006 \times d_1$ | 170                | $0,004 \times d_1$ | <input type="checkbox"/> | <input checked="" type="checkbox"/> | <input type="checkbox"/>            | <input checked="" type="checkbox"/> |
|          | 5.1 | 120                | $0,003 \times d_1$ | 110                            | $0,002 \times d_1$ | 140                  | $0,005 \times d_1$ | 160                | $0,004 \times d_1$ | <input type="checkbox"/> | <input checked="" type="checkbox"/> | <input type="checkbox"/>            | <input checked="" type="checkbox"/> |
| <b>M</b> | 1.1 | 90                 | $0,004 \times d_1$ | 80                             | $0,003 \times d_1$ | 100                  | $0,006 \times d_1$ | 120                | $0,004 \times d_1$ |                          |                                     | <input type="checkbox"/>            | <input checked="" type="checkbox"/> |
|          | 2.1 | 80                 | $0,003 \times d_1$ | 70                             | $0,002 \times d_1$ | 90                   | $0,005 \times d_1$ | 100                | $0,004 \times d_1$ |                          |                                     | <input type="checkbox"/>            | <input checked="" type="checkbox"/> |
|          | 3.1 | 60                 | $0,003 \times d_1$ | 50                             | $0,002 \times d_1$ | 70                   | $0,004 \times d_1$ | 80                 | $0,003 \times d_1$ |                          |                                     | <input type="checkbox"/>            | <input checked="" type="checkbox"/> |
|          | 4.1 | 40                 | $0,002 \times d_1$ | 40                             | $0,002 \times d_1$ | 50                   | $0,004 \times d_1$ | 60                 | $0,003 \times d_1$ |                          |                                     | <input type="checkbox"/>            | <input checked="" type="checkbox"/> |
| <b>K</b> | 1.1 | 190                | $0,006 \times d_1$ | 160                            | $0,005 \times d_1$ | 210                  | $0,01 \times d_1$  | 240                | $0,007 \times d_1$ | <input type="checkbox"/> | <input checked="" type="checkbox"/> | <input type="checkbox"/>            | <input checked="" type="checkbox"/> |
|          | 1.2 | 190                | $0,006 \times d_1$ | 160                            | $0,005 \times d_1$ | 210                  | $0,01 \times d_1$  | 240                | $0,007 \times d_1$ | <input type="checkbox"/> | <input checked="" type="checkbox"/> | <input type="checkbox"/>            | <input checked="" type="checkbox"/> |
|          | 2.1 | 170                | $0,006 \times d_1$ | 150                            | $0,004 \times d_1$ | 190                  | $0,009 \times d_1$ | 220                | $0,007 \times d_1$ | <input type="checkbox"/> | <input checked="" type="checkbox"/> | <input type="checkbox"/>            | <input checked="" type="checkbox"/> |
|          | 2.2 | 170                | $0,006 \times d_1$ | 150                            | $0,004 \times d_1$ | 190                  | $0,009 \times d_1$ | 220                | $0,007 \times d_1$ | <input type="checkbox"/> | <input checked="" type="checkbox"/> | <input type="checkbox"/>            | <input checked="" type="checkbox"/> |
|          | 3.1 | 160                | $0,005 \times d_1$ | 140                            | $0,004 \times d_1$ | 180                  | $0,008 \times d_1$ | 200                | $0,006 \times d_1$ | <input type="checkbox"/> | <input checked="" type="checkbox"/> | <input type="checkbox"/>            | <input checked="" type="checkbox"/> |
|          | 3.2 | 160                | $0,005 \times d_1$ | 140                            | $0,004 \times d_1$ | 180                  | $0,008 \times d_1$ | 200                | $0,006 \times d_1$ | <input type="checkbox"/> | <input checked="" type="checkbox"/> | <input type="checkbox"/>            | <input checked="" type="checkbox"/> |
|          | 4.1 | 140                | $0,005 \times d_1$ | 120                            | $0,004 \times d_1$ | 160                  | $0,007 \times d_1$ | 180                | $0,005 \times d_1$ | <input type="checkbox"/> | <input checked="" type="checkbox"/> | <input type="checkbox"/>            | <input checked="" type="checkbox"/> |
|          | 4.2 | 120                | $0,004 \times d_1$ | 110                            | $0,003 \times d_1$ | 140                  | $0,006 \times d_1$ | 160                | $0,005 \times d_1$ | <input type="checkbox"/> | <input checked="" type="checkbox"/> | <input type="checkbox"/>            | <input checked="" type="checkbox"/> |
| <b>N</b> | 1.1 |                    |                    |                                |                    |                      |                    |                    |                    |                          |                                     |                                     |                                     |
|          | 1.2 |                    |                    |                                |                    |                      |                    |                    |                    |                          |                                     |                                     |                                     |
|          | 1.3 |                    |                    |                                |                    |                      |                    |                    |                    |                          |                                     |                                     |                                     |
|          | 1.4 |                    |                    |                                |                    |                      |                    |                    |                    |                          |                                     |                                     |                                     |
|          | 1.5 |                    |                    |                                |                    |                      |                    |                    |                    |                          |                                     |                                     |                                     |
|          | 1.6 |                    |                    |                                |                    |                      |                    |                    |                    |                          |                                     |                                     |                                     |
|          | 2.1 | 200                | $0,005 \times d_1$ | 180                            | $0,004 \times d_1$ | 230                  | $0,008 \times d_1$ | 260                | $0,006 \times d_1$ |                          |                                     | <input type="checkbox"/>            | <input checked="" type="checkbox"/> |
|          | 2.2 | 200                | $0,005 \times d_1$ | 180                            | $0,004 \times d_1$ | 230                  | $0,008 \times d_1$ | 260                | $0,006 \times d_1$ |                          |                                     | <input type="checkbox"/>            | <input checked="" type="checkbox"/> |
|          | 2.3 | 200                | $0,005 \times d_1$ | 180                            | $0,004 \times d_1$ | 230                  | $0,008 \times d_1$ | 260                | $0,006 \times d_1$ |                          |                                     | <input type="checkbox"/>            | <input checked="" type="checkbox"/> |
|          | 2.4 | 170                | $0,004 \times d_1$ | 150                            | $0,003 \times d_1$ | 190                  | $0,006 \times d_1$ | 220                | $0,005 \times d_1$ |                          |                                     | <input type="checkbox"/>            | <input checked="" type="checkbox"/> |
|          | 2.5 | 170                | $0,004 \times d_1$ | 150                            | $0,003 \times d_1$ | 190                  | $0,006 \times d_1$ | 220                | $0,005 \times d_1$ |                          |                                     | <input type="checkbox"/>            | <input checked="" type="checkbox"/> |
|          | 2.6 | 170                | $0,004 \times d_1$ | 150                            | $0,003 \times d_1$ | 190                  | $0,006 \times d_1$ | 220                | $0,005 \times d_1$ |                          |                                     | <input type="checkbox"/>            | <input checked="" type="checkbox"/> |
|          | 2.7 | 110                | $0,004 \times d_1$ | 90                             | $0,003 \times d_1$ | 120                  | $0,006 \times d_1$ | 140                | $0,004 \times d_1$ |                          |                                     | <input type="checkbox"/>            | <input checked="" type="checkbox"/> |
|          | 2.8 | 110                | $0,004 \times d_1$ | 90                             | $0,003 \times d_1$ | 120                  | $0,006 \times d_1$ | 140                | $0,004 \times d_1$ |                          |                                     | <input type="checkbox"/>            | <input checked="" type="checkbox"/> |
|          | 3.1 |                    |                    |                                |                    |                      |                    |                    |                    |                          |                                     |                                     |                                     |
|          | 3.2 |                    |                    |                                |                    |                      |                    |                    |                    |                          |                                     |                                     |                                     |
| 4.1      |     |                    |                    |                                |                    |                      |                    |                    |                    |                          |                                     |                                     |                                     |
| 4.2      |     |                    |                    |                                |                    |                      |                    |                    |                    |                          |                                     |                                     |                                     |
| 4.3      |     |                    |                    |                                |                    |                      |                    |                    |                    |                          |                                     |                                     |                                     |
| 4.4      |     |                    |                    |                                |                    |                      |                    |                    |                    |                          |                                     |                                     |                                     |
| 5.1      |     |                    |                    |                                |                    |                      |                    |                    |                    |                          |                                     |                                     |                                     |
| 5.2      |     |                    |                    |                                |                    |                      |                    |                    |                    |                          |                                     |                                     |                                     |
| 5.3      |     |                    |                    |                                |                    |                      |                    |                    |                    |                          |                                     |                                     |                                     |
| <b>S</b> | 1.1 | 120                | $0,005 \times d_1$ | 110                            | $0,004 \times d_1$ | 140                  | $0,008 \times d_1$ | 160                | $0,006 \times d_1$ |                          |                                     | <input type="checkbox"/>            | <input checked="" type="checkbox"/> |
|          | 1.2 | 90                 | $0,005 \times d_1$ | 80                             | $0,004 \times d_1$ | 100                  | $0,007 \times d_1$ | 120                | $0,005 \times d_1$ |                          |                                     | <input type="checkbox"/>            | <input checked="" type="checkbox"/> |
|          | 1.3 | 60                 | $0,004 \times d_1$ | 50                             | $0,003 \times d_1$ | 70                   | $0,006 \times d_1$ | 80                 | $0,005 \times d_1$ |                          |                                     | <input type="checkbox"/>            | <input checked="" type="checkbox"/> |
|          | 2.1 | 90                 | $0,005 \times d_1$ | 80                             | $0,004 \times d_1$ | 100                  | $0,007 \times d_1$ | 110                | $0,005 \times d_1$ |                          |                                     | <input type="checkbox"/>            | <input checked="" type="checkbox"/> |
|          | 2.2 | 40                 | $0,004 \times d_1$ | 30                             | $0,003 \times d_1$ | 50                   | $0,006 \times d_1$ | 50                 | $0,004 \times d_1$ |                          |                                     | <input type="checkbox"/>            | <input checked="" type="checkbox"/> |
|          | 2.3 | 30                 | $0,003 \times d_1$ | 30                             | $0,002 \times d_1$ | 30                   | $0,005 \times d_1$ | 40                 | $0,004 \times d_1$ |                          |                                     | <input type="checkbox"/>            | <input checked="" type="checkbox"/> |
|          | 2.4 | 40                 | $0,004 \times d_1$ | 30                             | $0,003 \times d_1$ | 50                   | $0,006 \times d_1$ | 50                 | $0,004 \times d_1$ |                          |                                     | <input type="checkbox"/>            | <input checked="" type="checkbox"/> |
| 2.5      | 20  | $0,003 \times d_1$ | 20                 | $0,002 \times d_1$             | 30                 | $0,005 \times d_1$   | 30                 | $0,004 \times d_1$ |                    |                          | <input type="checkbox"/>            | <input checked="" type="checkbox"/> |                                     |
| 2.6      | 30  | $0,003 \times d_1$ | 30                 | $0,002 \times d_1$             | 30                 | $0,004 \times d_1$   | 40                 | $0,003 \times d_1$ |                    |                          | <input type="checkbox"/>            | <input checked="" type="checkbox"/> |                                     |
| <b>H</b> | 1.1 |                    |                    |                                |                    |                      |                    |                    |                    |                          |                                     |                                     |                                     |
|          | 1.2 |                    |                    |                                |                    |                      |                    |                    |                    |                          |                                     |                                     |                                     |
|          | 1.3 |                    |                    |                                |                    |                      |                    |                    |                    |                          |                                     |                                     |                                     |
|          | 1.4 |                    |                    |                                |                    |                      |                    |                    |                    |                          |                                     |                                     |                                     |
|          | 1.5 |                    |                    |                                |                    |                      |                    |                    |                    |                          |                                     |                                     |                                     |

$v_c$  = Schnittgeschwindigkeit · Cutting speed ■ = sehr gut geeignet · very suitable  
 $f_z$  = Vorschub pro Zahn · Feed per tooth □ = gut geeignet · suitable

- Hochleistungswerkzeug
- Mit 5-9 Schneiden
- Ungleiche Teilung
- Vibrationsarme Bearbeitung
- Innere Kühlschmierstoff-Zufuhr, Austritt axial (ICA)

- High performance tool
- With 5-9 flutes
- Variable spacing
- Low-vibration machining
- Internal coolant supply, axial exit (ICA)

N

ICA

HM

DIN 6535  
HA  
HB



Optional



Allround

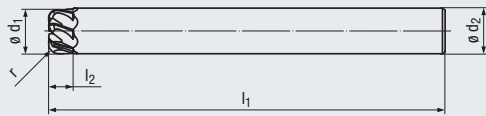

Beschichtung · Coating

TIALN

Einsatzgebiete – Material (siehe Seite 4)

- Speziell für hochfeste Werkstoffe geeignet
- Auch für Nickel-Basis-Legierungen einsetzbar
- Für die Zerspanung von Titan-Legierungen geeignet
- Einsatz in allen Turbinenwerkstoffen möglich

Applications – material (see page 4)

- Especially suitable for high-strength materials
- Also suitable in nickel-base alloys
- For the machining of titanium alloys
- Suitable in all turbine materials

|   |         |
|---|---------|
| P | 1.1-5.1 |
| M | 1.1-4.1 |
| K | 1.1-4.2 |
| N | 2.1-2.8 |
| S | 1.1-2.6 |

Bestell-Code · Order code

2676AZ

| $\varnothing d_1$ | r          | $l_2$ | $l_1$ | $\varnothing d_2$ | Z        | Dimens.-Code |   |  |  |
|-------------------|------------|-------|-------|-------------------|----------|--------------|---|--|--|
| f8                | $\pm 0,01$ |       |       | h6                | (Flutes) |              |   |  |  |
| 8                 | 1          | 3     | 80    | 8                 | 5        | .008010      | ● |  |  |
| 8                 | 2          | 4     | 80    | 8                 | 5        | .008020      | ● |  |  |
| 10                | 1          | 3     | 80    | 10                | 7        | .010010      | ● |  |  |
| 10                | 2          | 4     | 80    | 10                | 7        | .010020      | ● |  |  |
| 12                | 1          | 3     | 108   | 12                | 7        | .012010      | ● |  |  |
| 12                | 2          | 4     | 108   | 12                | 7        | .012020      | ● |  |  |
| 16                | 1          | 3     | 108   | 16                | 9        | .016010      | ● |  |  |
| 16                | 2          | 4     | 108   | 16                | 9        | .016020      | ● |  |  |

**Hartmetall-Torusfräser**  
Solid carbide torus end mills

**N**

Gültig für · Valid for  
2676AZ

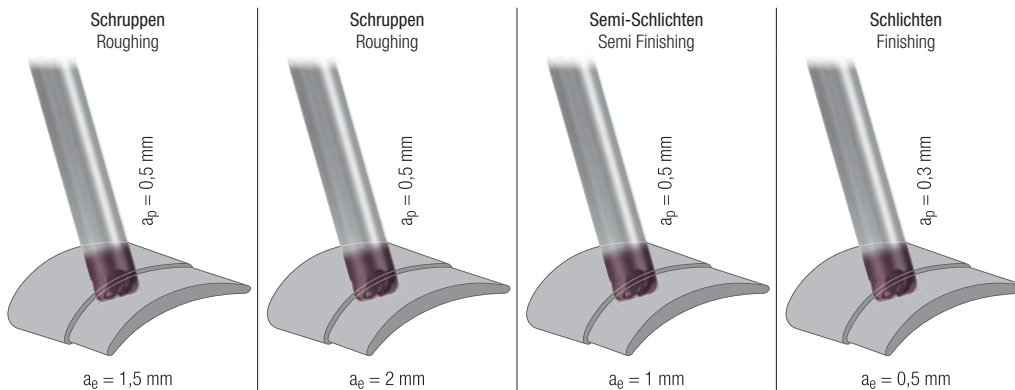

|          |     | Schruppen Roughing |                    | Semi-Schlichten Semi Finishing |                    | Schlichten Finishing |                    |                    |                    |                          |                                     |                                     |                                     |
|----------|-----|--------------------|--------------------|--------------------------------|--------------------|----------------------|--------------------|--------------------|--------------------|--------------------------|-------------------------------------|-------------------------------------|-------------------------------------|
|          |     | $V_c$ [m/min]      | $f_z$ [mm]         | $V_c$ [m/min]                  | $f_z$ [mm]         | $V_c$ [m/min]        | $f_z$ [mm]         |                    |                    |                          |                                     |                                     |                                     |
| <b>P</b> | 1.1 | 160                | $0,008 \times d_1$ | 140                            | $0,007 \times d_1$ | 180                  | $0,009 \times d_1$ | 200                | $0,006 \times d_1$ | <input type="checkbox"/> | <input checked="" type="checkbox"/> | <input type="checkbox"/>            | <input checked="" type="checkbox"/> |
|          | 2.1 | 150                | $0,007 \times d_1$ | 130                            | $0,006 \times d_1$ | 170                  | $0,008 \times d_1$ | 190                | $0,005 \times d_1$ | <input type="checkbox"/> | <input checked="" type="checkbox"/> | <input type="checkbox"/>            | <input checked="" type="checkbox"/> |
|          | 3.1 | 140                | $0,006 \times d_1$ | 120                            | $0,006 \times d_1$ | 160                  | $0,007 \times d_1$ | 180                | $0,005 \times d_1$ | <input type="checkbox"/> | <input checked="" type="checkbox"/> | <input type="checkbox"/>            | <input type="checkbox"/>            |
|          | 4.1 | 130                | $0,006 \times d_1$ | 110                            | $0,005 \times d_1$ | 150                  | $0,006 \times d_1$ | 170                | $0,004 \times d_1$ | <input type="checkbox"/> | <input checked="" type="checkbox"/> | <input type="checkbox"/>            | <input type="checkbox"/>            |
|          | 5.1 | 120                | $0,005 \times d_1$ | 110                            | $0,004 \times d_1$ | 140                  | $0,005 \times d_1$ | 160                | $0,004 \times d_1$ | <input type="checkbox"/> | <input checked="" type="checkbox"/> | <input type="checkbox"/>            | <input type="checkbox"/>            |
| <b>M</b> | 1.1 | 90                 | $0,006 \times d_1$ | 80                             | $0,005 \times d_1$ | 100                  | $0,006 \times d_1$ | 120                | $0,004 \times d_1$ |                          |                                     | <input type="checkbox"/>            | <input checked="" type="checkbox"/> |
|          | 2.1 | 80                 | $0,005 \times d_1$ | 70                             | $0,004 \times d_1$ | 90                   | $0,005 \times d_1$ | 100                | $0,004 \times d_1$ |                          |                                     | <input type="checkbox"/>            | <input checked="" type="checkbox"/> |
|          | 3.1 | 60                 | $0,004 \times d_1$ | 50                             | $0,004 \times d_1$ | 70                   | $0,005 \times d_1$ | 80                 | $0,003 \times d_1$ |                          |                                     | <input type="checkbox"/>            | <input checked="" type="checkbox"/> |
|          | 4.1 | 40                 | $0,004 \times d_1$ | 40                             | $0,003 \times d_1$ | 50                   | $0,004 \times d_1$ | 60                 | $0,003 \times d_1$ |                          |                                     | <input type="checkbox"/>            | <input checked="" type="checkbox"/> |
| <b>K</b> | 1.1 | 190                | $0,01 \times d_1$  | 160                            | $0,008 \times d_1$ | 210                  | $0,011 \times d_1$ | 240                | $0,007 \times d_1$ | <input type="checkbox"/> | <input checked="" type="checkbox"/> | <input type="checkbox"/>            | <input type="checkbox"/>            |
|          | 1.2 | 190                | $0,01 \times d_1$  | 160                            | $0,008 \times d_1$ | 210                  | $0,011 \times d_1$ | 240                | $0,007 \times d_1$ | <input type="checkbox"/> | <input checked="" type="checkbox"/> | <input type="checkbox"/>            | <input type="checkbox"/>            |
|          | 2.1 | 170                | $0,009 \times d_1$ | 150                            | $0,008 \times d_1$ | 190                  | $0,01 \times d_1$  | 220                | $0,007 \times d_1$ | <input type="checkbox"/> | <input checked="" type="checkbox"/> | <input type="checkbox"/>            | <input type="checkbox"/>            |
|          | 2.2 | 170                | $0,009 \times d_1$ | 150                            | $0,008 \times d_1$ | 190                  | $0,01 \times d_1$  | 220                | $0,007 \times d_1$ | <input type="checkbox"/> | <input checked="" type="checkbox"/> | <input type="checkbox"/>            | <input type="checkbox"/>            |
|          | 3.1 | 160                | $0,008 \times d_1$ | 140                            | $0,007 \times d_1$ | 180                  | $0,009 \times d_1$ | 200                | $0,006 \times d_1$ | <input type="checkbox"/> | <input checked="" type="checkbox"/> | <input type="checkbox"/>            | <input type="checkbox"/>            |
|          | 3.2 | 160                | $0,008 \times d_1$ | 140                            | $0,007 \times d_1$ | 180                  | $0,009 \times d_1$ | 200                | $0,006 \times d_1$ | <input type="checkbox"/> | <input checked="" type="checkbox"/> | <input type="checkbox"/>            | <input type="checkbox"/>            |
|          | 4.1 | 140                | $0,007 \times d_1$ | 120                            | $0,006 \times d_1$ | 160                  | $0,008 \times d_1$ | 180                | $0,005 \times d_1$ | <input type="checkbox"/> | <input checked="" type="checkbox"/> | <input type="checkbox"/>            | <input type="checkbox"/>            |
|          | 4.2 | 120                | $0,006 \times d_1$ | 110                            | $0,006 \times d_1$ | 140                  | $0,007 \times d_1$ | 160                | $0,005 \times d_1$ | <input type="checkbox"/> | <input checked="" type="checkbox"/> | <input type="checkbox"/>            | <input type="checkbox"/>            |
| <b>N</b> | 1.1 |                    |                    |                                |                    |                      |                    |                    |                    |                          |                                     |                                     |                                     |
|          | 1.2 |                    |                    |                                |                    |                      |                    |                    |                    |                          |                                     |                                     |                                     |
|          | 1.3 |                    |                    |                                |                    |                      |                    |                    |                    |                          |                                     |                                     |                                     |
|          | 1.4 |                    |                    |                                |                    |                      |                    |                    |                    |                          |                                     |                                     |                                     |
|          | 1.5 |                    |                    |                                |                    |                      |                    |                    |                    |                          |                                     |                                     |                                     |
|          | 1.6 |                    |                    |                                |                    |                      |                    |                    |                    |                          |                                     |                                     |                                     |
|          | 2.1 | 200                | $0,008 \times d_1$ | 180                            | $0,007 \times d_1$ | 230                  | $0,009 \times d_1$ | 260                | $0,006 \times d_1$ |                          |                                     | <input type="checkbox"/>            | <input checked="" type="checkbox"/> |
|          | 2.2 | 200                | $0,008 \times d_1$ | 180                            | $0,007 \times d_1$ | 230                  | $0,009 \times d_1$ | 260                | $0,006 \times d_1$ |                          |                                     | <input type="checkbox"/>            | <input checked="" type="checkbox"/> |
|          | 2.3 | 200                | $0,008 \times d_1$ | 180                            | $0,007 \times d_1$ | 230                  | $0,009 \times d_1$ | 260                | $0,006 \times d_1$ |                          |                                     | <input type="checkbox"/>            | <input checked="" type="checkbox"/> |
|          | 2.4 | 170                | $0,006 \times d_1$ | 150                            | $0,006 \times d_1$ | 190                  | $0,007 \times d_1$ | 220                | $0,005 \times d_1$ |                          |                                     | <input type="checkbox"/>            | <input checked="" type="checkbox"/> |
|          | 2.5 | 170                | $0,006 \times d_1$ | 150                            | $0,006 \times d_1$ | 190                  | $0,007 \times d_1$ | 220                | $0,005 \times d_1$ |                          |                                     | <input type="checkbox"/>            | <input checked="" type="checkbox"/> |
|          | 2.6 | 170                | $0,006 \times d_1$ | 150                            | $0,006 \times d_1$ | 190                  | $0,007 \times d_1$ | 220                | $0,005 \times d_1$ |                          |                                     | <input type="checkbox"/>            | <input checked="" type="checkbox"/> |
|          | 2.7 | 110                | $0,006 \times d_1$ | 90                             | $0,005 \times d_1$ | 120                  | $0,006 \times d_1$ | 140                | $0,004 \times d_1$ |                          |                                     | <input type="checkbox"/>            | <input checked="" type="checkbox"/> |
|          | 2.8 | 110                | $0,006 \times d_1$ | 90                             | $0,005 \times d_1$ | 120                  | $0,006 \times d_1$ | 140                | $0,004 \times d_1$ |                          |                                     | <input type="checkbox"/>            | <input checked="" type="checkbox"/> |
|          | 3.1 |                    |                    |                                |                    |                      |                    |                    |                    |                          |                                     |                                     |                                     |
|          | 3.2 |                    |                    |                                |                    |                      |                    |                    |                    |                          |                                     |                                     |                                     |
| 4.1      |     |                    |                    |                                |                    |                      |                    |                    |                    |                          |                                     |                                     |                                     |
| 4.2      |     |                    |                    |                                |                    |                      |                    |                    |                    |                          |                                     |                                     |                                     |
| 4.3      |     |                    |                    |                                |                    |                      |                    |                    |                    |                          |                                     |                                     |                                     |
| 4.4      |     |                    |                    |                                |                    |                      |                    |                    |                    |                          |                                     |                                     |                                     |
| 5.1      |     |                    |                    |                                |                    |                      |                    |                    |                    |                          |                                     |                                     |                                     |
| 5.2      |     |                    |                    |                                |                    |                      |                    |                    |                    |                          |                                     |                                     |                                     |
| 5.3      |     |                    |                    |                                |                    |                      |                    |                    |                    |                          |                                     |                                     |                                     |
| <b>S</b> | 1.1 | 120                | $0,008 \times d_1$ | 110                            | $0,007 \times d_1$ | 140                  | $0,009 \times d_1$ | 160                | $0,006 \times d_1$ |                          |                                     | <input type="checkbox"/>            | <input checked="" type="checkbox"/> |
|          | 1.2 | 90                 | $0,007 \times d_1$ | 80                             | $0,006 \times d_1$ | 100                  | $0,008 \times d_1$ | 120                | $0,005 \times d_1$ |                          |                                     | <input type="checkbox"/>            | <input checked="" type="checkbox"/> |
|          | 1.3 | 60                 | $0,006 \times d_1$ | 50                             | $0,006 \times d_1$ | 70                   | $0,007 \times d_1$ | 80                 | $0,005 \times d_1$ |                          |                                     | <input type="checkbox"/>            | <input checked="" type="checkbox"/> |
|          | 2.1 | 90                 | $0,007 \times d_1$ | 80                             | $0,006 \times d_1$ | 100                  | $0,008 \times d_1$ | 110                | $0,005 \times d_1$ |                          |                                     | <input type="checkbox"/>            | <input checked="" type="checkbox"/> |
|          | 2.2 | 40                 | $0,006 \times d_1$ | 30                             | $0,005 \times d_1$ | 50                   | $0,006 \times d_1$ | 50                 | $0,004 \times d_1$ |                          |                                     | <input type="checkbox"/>            | <input checked="" type="checkbox"/> |
|          | 2.3 | 30                 | $0,005 \times d_1$ | 30                             | $0,004 \times d_1$ | 30                   | $0,005 \times d_1$ | 40                 | $0,004 \times d_1$ |                          |                                     | <input type="checkbox"/>            | <input checked="" type="checkbox"/> |
|          | 2.4 | 40                 | $0,006 \times d_1$ | 30                             | $0,005 \times d_1$ | 50                   | $0,006 \times d_1$ | 50                 | $0,004 \times d_1$ |                          |                                     | <input type="checkbox"/>            | <input checked="" type="checkbox"/> |
| 2.5      | 20  | $0,005 \times d_1$ | 20                 | $0,004 \times d_1$             | 30                 | $0,005 \times d_1$   | 30                 | $0,004 \times d_1$ |                    |                          | <input type="checkbox"/>            | <input checked="" type="checkbox"/> |                                     |
| 2.6      | 30  | $0,004 \times d_1$ | 30                 | $0,004 \times d_1$             | 30                 | $0,005 \times d_1$   | 40                 | $0,003 \times d_1$ |                    |                          | <input type="checkbox"/>            | <input checked="" type="checkbox"/> |                                     |
| <b>H</b> | 1.1 |                    |                    |                                |                    |                      |                    |                    |                    |                          |                                     |                                     |                                     |
|          | 1.2 |                    |                    |                                |                    |                      |                    |                    |                    |                          |                                     |                                     |                                     |
|          | 1.3 |                    |                    |                                |                    |                      |                    |                    |                    |                          |                                     |                                     |                                     |
|          | 1.4 |                    |                    |                                |                    |                      |                    |                    |                    |                          |                                     |                                     |                                     |
|          | 1.5 |                    |                    |                                |                    |                      |                    |                    |                    |                          |                                     |                                     |                                     |

$v_c$  = Schnittgeschwindigkeit · Cutting speed  
 $f_z$  = Vorschub pro Zahn · Feed per tooth

■ = sehr gut geeignet · very suitable  
□ = gut geeignet · suitable

## Walter Cordbarlag GmbH & Co. KG

🏠 Am Poggenpohl 6  
33619 Bielefeld

☎ +49 521.492751

📠 +49 521.493756

✉ info@cordbarlag.de

🌐 www.cordbarlag.de

