

Gewindeformer



EMUGE

Gewindeschneidtechnik · Spanntechnik
Thread Cutting Technology · Clamping Technology



Gewindeformer Cold-Forming Taps

Seite · Page

Übersicht	Contents	269 - 271
Wegweiser und Schnittwerte	Product finder and cutting data	272 - 277
Produktseiten	Product pages	278 - 304
Technische Informationen	Technical information	305 - 324

Cut&Form – Innengewindefertigung durch Kombination von Spanen und Umformen

Das Innengewinde-Fertigungssystem Cut&Form ist eine Kombination aus spanenden und umformenden Verfahren, welche jeweils einen bestimmten Teil des Gewindeprofils erzeugen.

Cut&Form – Production of internal threads by a combination of machining and cold forming

The internal thread production system Cut&Form is a combination of machining and cold-forming processes which each produce a specific part of the thread profile.



- Verfestigung des Gewindes und Erhöhung der Dauerfestigkeit
- Gewindeformen von großen Gewindesteigungen
- Gewindeformen von schlecht fließenden Werkstoffen
- Erzeugung eines eng tolerierten Innengewindekerndurchmessers ohne „Kralle“
- Glättung der Gewindeoberfläche

- Strengthened threads and increased long-term resistance
- Cold forming of large threads with coarse pitch
- Cold forming of threads in difficult materials
- Production of a narrow-tolerance minor diameter without space pocket
- Extra smooth thread surfaces

Gewindeformer mit verstärktem Schaft
Cold-forming taps with reinforced shank



Drück 1
InnoForm 1

Gewindeformer mit durchfallendem Schaft
Cold-forming taps with reduced shank



Drück 2
InnoForm 2

Gewindeformer mit langem Schaft
Cold-forming taps with long shank



InnoForm 2-LF3
InnoForm 2-LF4

Gewindeformer mit extra-langem Schaft
Cold-forming taps with extra long shank



InnoForm 1-LS
InnoForm 2-LS

Seite · Page

278 - 285	287 - 290	292 - 293	286, 291	M
294 - 295	296 - 298			MF
299	300			UNC
301	302			UNF
	303			G (BSP)
304				LK-M

Seite · Page



Kühlschmierstoffe
Coolant-lubricants

238 - 239



Spezial-Schaftverlängerungen
Special shank extensions

240 - 242



- Product Finder
- Vc
- M
- MF
- UNC
- UNF
- G
- SELF-LOCK
- Tech. Info

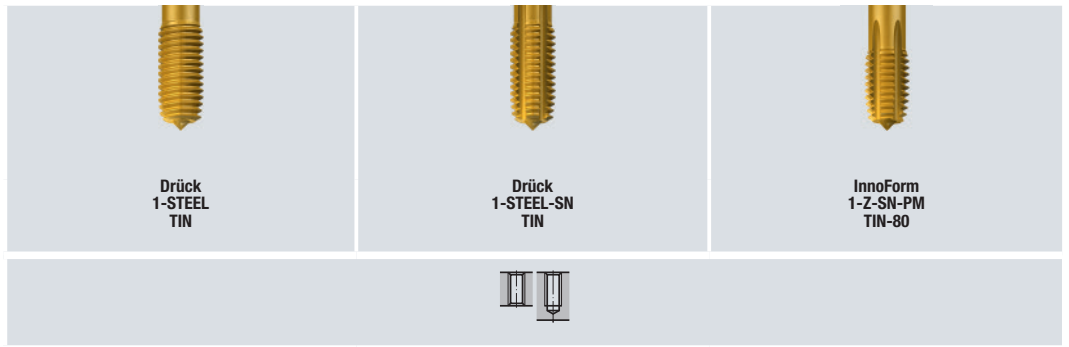

Seite · Page

M	6GX	279	279	283
----------	------------	-----	-----	-----



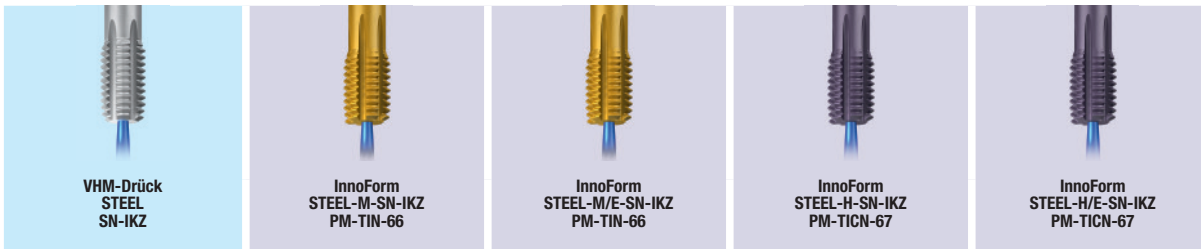

Product Finder

Vc

M

MF

UNC

UNF

G

SELF-LOCK

Tech. Info

Seite · Page

279	279, 287	279, 287	279, 288	280, 288
	296	296	297	297

M
MF
UNC
UNF
G (BSP)



Seite · Page

280	281	281	281	282

M
MF
UNC
UNF
G (BSP)

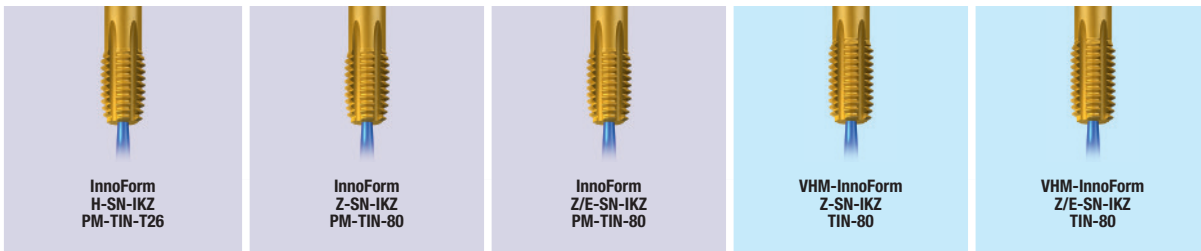

Seite · Page

283, 289, 292, 293	283, 286, 289, 291	283, 289	284	284
297	295, 297			
	299, 300			
	301, 302			
	303			

M
MF
UNC
UNF
G (BSP)

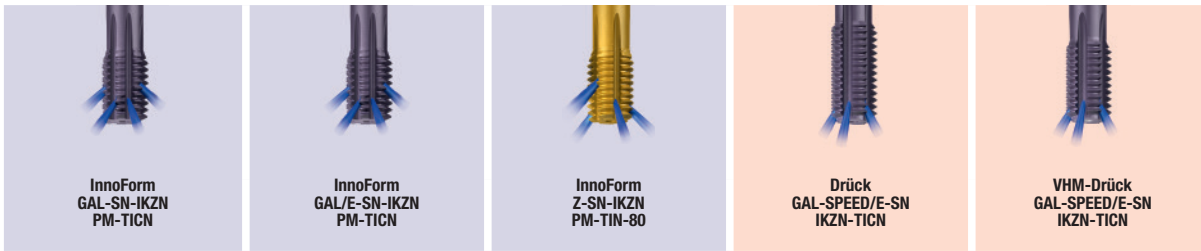

Seite · Page

281	282	283, 289, 292, 293	285, 290	285, 290
			295, 298	295, 298

M
MF
UNC
UNF
G (BSP)

- Product Finder
- V_c
- M
- MF
- UNC
- UNF
- G
- SELF-LOCK
- Tech. Info

Wegweiser und Schnittwerte

Bitte beachten:

Die in den jeweiligen Spalten angegebenen Umfangsgeschwindigkeiten (v_c in m/min) sind Richtwerte, welche je nach Einsatzbedingungen (Material, Schmierung, Maschine, usw.) angepasst werden müssen.

Die Eignung ist folgendermaßen gekennzeichnet:

- Gewindeformer sehr gut geeignet
- Gewindeformer gut geeignet

 = DIN-Form / Gänge (Anformkegellänge)

Internationaler Werkstoffvergleich siehe Seite 838 - 851.

Product finder and cutting data

Please note:

The circumferential speeds (v_c in m/min) listed in the respective columns are standard values which have to be adjusted to individual work conditions (material, lubrication, machine etc.).

The suitability is marked as follows:

- Cold-forming tap is very suitable
- Cold-forming tap is suitable

 = DIN form / threads (lead taper length)

International comparison of materials, see page 838 - 851.

Einsatzgebiete – Material Applications – material		Material-Beispiele Material examples	Material-Nummern Material numbers
P	Stahlwerkstoffe Kaltfließpressstähle, Baustähle, Automatenstähle, u.a.	Steel materials Cold-extrusion steels, Construction steels, Free-cutting steels, etc.	≤ 600 N/mm ² Cq15 1.1132 S235JR (St37-2) 1.0037 10SPb20 1.0722
	2.1 Baustähle, Einsatzstähle, Stahlguss, u.a.	Construction steels, Cementation steels, Steel castings, etc.	≤ 800 N/mm ² E360 (St70-2) 1.0070 16MnCr5 1.7131 GS-25CrMo4 1.7218
	3.1 Einsatzstähle, Vergütungsstähle, Kaltarbeitsstähle, u.a.	Cementation steels, Heat-treatable steels, Cold work steels, etc.	≤ 1000 N/mm ² 20MoCr3 1.7320 42CrMo4 1.7225 102Cr6 1.2067 50CrMo4 1.7228
	4.1 Vergütungsstähle, Kaltarbeitsstähle, Nitrierstähle, u.a.	Heat-treatable steels, Cold work steels, Nitriding steels, etc.	≤ 1200 N/mm ² X45NiCrMo4 1.2767 31CrMo12 1.8515 X38CrMoV5-3 1.2367
	5.1 Hochlegierte Stähle, Kaltarbeitsstähle, Warmarbeitsstähle, u.a.	High-alloyed steels, Cold work steels, Hot work steels, etc.	≤ 1400 N/mm ² X100CrMoV8-1-1 1.2990 X40CrMoV5-1 1.2344
M	Nichtrostende Stahlwerkstoffe 1.1 Ferritisch, martensitisch	Stainless steel materials Ferritic, martensitic	≤ 950 N/mm ² X2CrTi12 1.4512
	2.1 Austenitisch	Austenitic	≤ 950 N/mm ² X6CrNiMoTi17-12-2 1.4571
	3.1 Austenitisch-ferritisch (Duplex)	Austenitic-ferritic (Duplex)	≤ 1100 N/mm ² X2CrNiMoN22-5-3 1.4462
	4.1 Austenitisch-ferritisch hitzebeständig (Super Duplex)	Austenitic-ferritic heat-resistant (Super Duplex)	≤ 1250 N/mm ² X2CrNiMoN25-7-4 1.4410
K	Gusswerkstoffe 1.1 Gusseisen mit Lamellengrafit (GJL)	Cast materials Cast iron with lamellar graphite (GJL)	100-250 N/mm ² EN-GJL-200 (GG20) EN-JL-1030 250-450 N/mm ² EN-GJL-300 (GG30) EN-JL-1050
	2.1 Gusseisen mit Kugelgrafit (GJS)	Cast iron with nodular graphite (GJS)	350-500 N/mm ² EN-GJS-400-15 (GGG40) EN-JS-1030 500-900 N/mm ² EN-GJS-700-2 (GGG70) EN-JS-1070
	3.1 Gusseisen mit Vermiculargrafit (GJV)	Cast iron with vermicular graphite (GJV)	300-400 N/mm ² GJV 300 400-500 N/mm ² GJV 450
	4.1 Temperguss (GTMW, GTMB)	Malleable cast iron (GTMW, GTMB)	250-500 N/mm ² EN-GJMW-350-4 (GTW-35) EN-JM-1010 500-800 N/mm ² EN-GJMB-450-6 (GTS-45) EN-JM-1140
	1.1 Aluminium-Legierungen	Non ferrous materials Aluminium alloys	≤ 200 N/mm ² EN AW-AlMn1 EN AW-3103 ≤ 350 N/mm ² EN AW-AlMgSi EN AW-6060 ≤ 550 N/mm ² EN AW-AlZn5Mg3Cu EN AW-7022 Si ≤ 7% EN AC-AlMg5 EN AC-51300 7% < Si ≤ 12% EN AC-AISi9Cu3 EN AC-46500 12% < Si ≤ 17% GD-AISi17Cu4FeMg
	2.1 Reinkupfer, niedriglegiertes Kupfer	Copper alloys Pure copper, low-alloyed copper	≤ 400 N/mm ² E-Cu 57 EN CW 004 A ≤ 550 N/mm ² CuZn37 (Ms63) EN CW 508 L
	2.2 Kupfer-Zink-Legierungen (Messing, langspanend)	Copper-zinc alloys (brass, long-chipping)	≤ 550 N/mm ² CuZn36Pb3 (Ms58) EN CW 603 N
2.3 Kupfer-Zink-Legierungen (Messing, kurzspanend)	Copper-zinc alloys (brass, short-chipping)	≤ 800 N/mm ² CuAl10Ni5Fe4 EN CW 307 G ≤ 700 N/mm ² CuSn8P EN CW 459 K	
2.4 Kupfer-Aluminium-Legierungen (Alubronze, langspanend)	Copper-aluminium alloys (alu bronze, long-chipping)	≤ 400 N/mm ² CuSn7 ZnPb (Rg7) 2.1090	
2.5 Kupfer-Zinn-Legierungen (Zinnbronze, langspanend)	Copper-tin alloys (tin bronze, long-chipping)	≤ 600 N/mm ² (AMPCO® 8)	
2.6 Kupfer-Zinn-Legierungen (Zinnbronze, kurzspanend)	Copper-tin alloys (tin bronze, short-chipping)	≤ 1400 N/mm ² (AMPCO® 45)	
2.7 Kupfer-Sonderlegierungen	Special copper alloys		
2.8 Kupfer-Sonderlegierungen	Special copper alloys		
3.1 Magnesium-Legierungen	Magnesium alloys Magnesium wrought alloys	≤ 500 N/mm ² MgAl6Zn 3.5612	
3.2 Magnesium-Gusslegierungen	Magnesium cast alloys	≤ 500 N/mm ² EN-MCMgAl9Zn1 EN-MC21120	
N	Kunststoffe 4.1 Duroplaste (kurzspanend)	Synthetics Duroplastics (short-chipping)	Bakelit, Pertinax
	4.2 Thermoplaste (langspanend)	Thermoplastics (long-chipping)	PMMA, POM, PVC
	4.3 Faserverstärkte Kunststoffe (Fasergehalt ≤ 30%)	Fibre-reinforced synthetics (fibre content ≤ 30%)	GFK, CFK, AFK
	4.4 Faserverstärkte Kunststoffe (Fasergehalt > 30%)	Fibre-reinforced synthetics (fibre content > 30%)	GFK, CFK, AFK
S	Besondere Werkstoffe 5.1 Grafit	Special materials Graphite	C 8000
	5.2 Wolfram-Kupfer-Legierungen	Tungsten-copper alloys	W-Cu 80/20
	5.3 Verbundwerkstoffe	Composite materials	Hyllite, Alucobond
H	Spezialwerkstoffe Titan-Legierungen	Special materials Titanium alloys	≤ 450 N/mm ² Ti1 3.7025 ≤ 900 N/mm ² TiAl6V4 3.7165 ≤ 1250 N/mm ² TiAl4Mo4Sn2 3.7185
	1.1 Reintitan	Pure titanium	
	1.2 Titan-Legierungen	Titanium alloys	
	1.3 Titan-Legierungen	Titanium alloys	
	Nickel-, Kobalt- und Eisen-Legierungen	Nickel alloys, cobalt alloys and iron alloys	
	2.1 Reinnickel	Pure nickel	≤ 600 N/mm ² Ni 99.6 2.4060
	2.2 Nickel-Basis-Legierungen	Nickel-base alloys	≤ 1000 N/mm ² Monel 400 2.4360 ≤ 1600 N/mm ² Inconel 718 2.4668
	2.3 Nickel-Basis-Legierungen	Nickel-base alloys	≤ 1000 N/mm ² Udimet 605
	2.4 Kobalt-Basis-Legierungen	Cobalt-base alloys	≤ 1600 N/mm ² Haynes 25 2.4964
	2.5 Eisen-Basis-Legierungen	Iron-base alloys	≤ 1500 N/mm ² Incoloy 800 1.4958
2.6 Eisen-Basis-Legierungen	Iron-base alloys		
H	Harte Werkstoffe 1.1 Hochfeste Stähle, gehärtete Stähle, Hartguss	Hard materials High strength steels, hardened steels, hard castings	44 - 50 HRC Weldox 1100 50 - 55 HRC Hardox 550 55 - 60 HRC Armax 600T 60 - 63 HRC Ferro-Titanit 63 - 66 HRC HSSE
	1.1 Hochfeste Stähle, gehärtete Stähle, Hartguss	High strength steels, hardened steels, hard castings	
	1.2 Hochfeste Stähle, gehärtete Stähle, Hartguss	High strength steels, hardened steels, hard castings	
	1.3 Hochfeste Stähle, gehärtete Stähle, Hartguss	High strength steels, hardened steels, hard castings	
	1.4 Hochfeste Stähle, gehärtete Stähle, Hartguss	High strength steels, hardened steels, hard castings	
1.5 Hochfeste Stähle, gehärtete Stähle, Hartguss	High strength steels, hardened steels, hard castings		



Product Finder

v_c

M

MF

UNC

UNF

G

SELF-LOCK

Tech. Info

Drück STEEL NT

Drück STEEL CR

Drück STEEL TIN

Drück STEEL-SN NT

Drück STEEL-SN CR

Drück STEEL-SN TIN

VHM-Drück STEEL SN-IKZ

InnoForm STEEL-BL/D PM-TIN

InnoForm STEEL-M-SN PM-TIN-66

C / 2-3

C / 2-3

C / 2-3

C / 2-3

C / 2-3

C / 2-3

C / 2-3

D / 4-5

C / 2-3

max. 3 x d₁



max. 3 x d₁



max. 3 x d₁



max. 3 x d₁



Gewindetiefe und Lochtiefe
Thread depth and hole type

M
MF
UNC
UNF
UNEf, UN-8
G, Rp
NPSM, NPST
NPT, NPTF, Rc
W
BSW, BSF
Pg
MJ
UNJC, UNJF
EG (ST)
LK-M
Tr, Tr-F, Rd

278

278

278, 287
294, 296
299, 300
301, 302

278

278

279, 287
294, 296
299, 300
301, 302

279

279

279, 287
296

304

304

15 - 45

20 - 80

15 - 45

20 - 80

20 - 80

20 - 80

1.1

10 - 40

20 - 60

10 - 40

20 - 60

20 - 60

20 - 60

2.1

5 - 25

10 - 40

5 - 25

10 - 40

10 - 40

10 - 40

3.1

P

2 - 20

10 - 30

10 - 30

4.1

5.1

10 - 25 ²⁾
10 - 25 ²⁾

10 - 25 ²⁾
10 - 25 ²⁾

1.1

2.1

3.1

4.1

1.1

1.2

2.1

2.2

3.1

3.2

4.1

4.2

20 - 60

1.1

1.2

1.3

1.4

1.5

1.6

15 - 40
15 - 40
15 - 40
15 - 40

20 - 60
20 - 60

15 - 40
15 - 40
15 - 40
15 - 40

20 - 60
20 - 60

20 - 60
20 - 60

2.1

2.2

2.3

2.4

2.5

2.6

2.7

2.8

3.1

3.2

4.1

4.2

4.3

4.4

5.1

5.2

5.3

1.1

1.2

1.3

1.4

1.5

1.5

S

H



Product Finder

V_c

M

MF

UNC

UNF

G

SELF-LOCK

Tech. Info



Gewindetiefe und Lochform
Thread depth and hole type

M
MF
UNC
UNF
UNEf, UN-8
G, Rp
NPSM, NPSF
NPT, NPTF, Rc
W
BSW, BSF
Pg
MJ
UNJC, UNJF
EG (STI)
LK-M
Tr, Tr-F, Rd

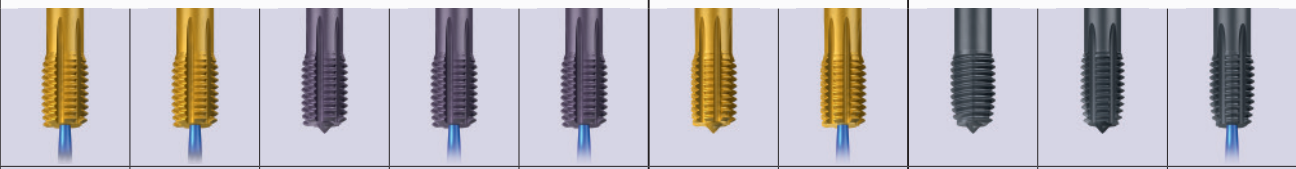

	InnoForm STEEL-M-SN IKZ-PM-TIN-66	InnoForm STEEL-M/E-SN IKZ-PM-TIN-66	InnoForm STEEL-H-SN IKZ-PM-TICN-67	InnoForm STEEL-H-SN IKZ-PM-TICN-67	InnoForm STEEL-H/E-SN IKZ-PM-TICN-67	InnoForm VA/E-SN PM-TIN-T26	InnoForm VA/E-SN-IKZ PM-TIN-T26	InnoForm AL PM-GLT-8	InnoForm AL-SN PM-GLT-8	InnoForm AL-SN-IKZ PM-GLT-8
	C / 2-3	E / 1,5-2	C / 2-3	C / 2-3	E / 1,5-2	E / 1,5-2	E / 1,5-2	C / 2-3	C / 2-3	C / 2-3
	max. 3 x d ₁ 		max. 3 x d ₁ 		max. 3 x d ₁ 		max. 3 x d ₁ 		max. 3 x d ₁ 	
	279, 287 296	279, 287 296	279, 288 297	279, 288 297	280, 288 297	280	280	281	281	281

Seite . Page

P	1.1	20 - 80	20 - 80			20 - 80	20 - 80			
	2.1	20 - 60	20 - 60			20 - 60	20 - 60			
	3.1	10 - 40	10 - 40	10 - 40	10 - 40	10 - 40	10 - 40	10 - 40		
	4.1	10 - 30	10 - 30	10 - 30	10 - 30	10 - 30	10 - 30	10 - 30		
	5.1			10 - 20	10 - 20	10 - 20				
M	1.1					10 - 25 ²⁾	10 - 25 ²⁾			
	2.1					10 - 25 ²⁾	10 - 25 ²⁾			
	3.1					5 - 20 ²⁾	5 - 20 ²⁾			
	4.1									
K	1.1									
	1.2									
	2.1	20 - 60	20 - 60	20 - 60	20 - 60	20 - 60				
	2.2									
	3.1									
	3.2									
	4.1									
N	1.1							20 - 60	20 - 60	20 - 60
	1.2							20 - 60	20 - 60	20 - 60
	1.3							20 - 60	20 - 60	20 - 60
	1.4							20 - 60	20 - 60	20 - 60
	1.5							20 - 60	20 - 60	20 - 60
	1.6									
	2.1							20 - 40	20 - 40	20 - 40
	2.2							40 - 80	40 - 80	40 - 80
	2.3									
	2.4									
	2.5									
	2.6									
	2.7									
	2.8									
	3.1									
3.2										
4.1										
4.2										
4.3										
4.4										
5.1										
5.2										
5.3										
S	1.1									
	1.2									
	1.3									
	2.1									
	2.2									
	2.6									
H	1.1									
	1.2									
	1.3									
	1.4									
	1.5									

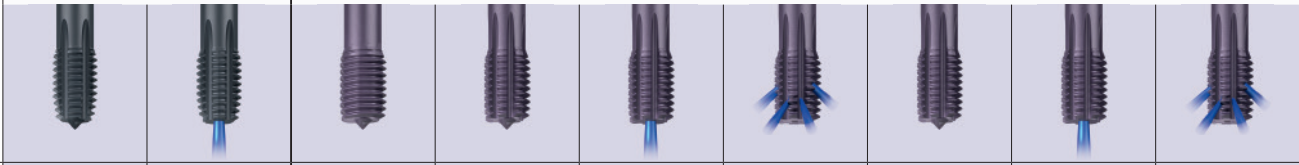

InnoForm AL/E-SN PM-GLT-8	InnoForm AL/E-SN-IKZ PM-GLT-8	InnoForm GAL PM-TICN	InnoForm GAL-SN PM-TICN	InnoForm GAL-SN-IKZ PM-TICN	InnoForm GAL-SN-IKZN PM-TICN	InnoForm GAL/E-SN PM-TICN	InnoForm GAL/E-SN-IKZ PM-TICN	InnoForm GAL/E-SN-IKZN PM-TICN
---------------------------	-------------------------------	----------------------	-------------------------	-----------------------------	------------------------------	---------------------------	-------------------------------	--------------------------------

E / 1,5-2	E / 1,5-2	C / 2-3	C / 2-3	C / 2-3	C / 2-3	E / 1,5-2	E / 1,5-2	E / 1,5-2
-----------	-----------	---------	---------	---------	---------	-----------	-----------	-----------

max. 3 x d ₁	max. 3 x d ₁	max. 3 x d ₁		max. 3 x d ₁	max. 3 x d ₁		max. 3 x d ₁	max. 3 x d ₁
-------------------------	-------------------------	-------------------------	--	-------------------------	-------------------------	--	-------------------------	-------------------------

281	281	281	281	281	281	282	282	282
-----	-----	-----	-----	-----	-----	-----	-----	-----

Gewindetiefe und Lochform
Thread depth and hole type

M
MF
UNC
UNF
UNEJ, UN-8
G, Rp
NPSM, NPSF
NPT, NPTF, Rc
W
BSW, BSF
Pg
MJ
UNJC, UNJF
EG (ST)
LK-M
Tr, Tr-F, Rd

Product Finder

V_c

M

MF

UNC

UNF

G

SELF-LOCK

Tech. Info

Seite · Page



										1.1
										2.1
										3.1
										4.1
										5.1
										1.1
										2.1
										3.1
										4.1
										1.1
										1.2
										2.1
										2.2
										3.1
										3.2
										4.1
										4.2
										1.1
										1.2
										1.3
										1.4
										1.5
										1.6
										2.1
										2.2
										2.3
										2.4
										2.5
										2.6
										2.7
										2.8
										3.1
										3.2
										4.1
										4.2
										4.3
										4.4
										5.1
										5.2
										5.3
										1.1
										1.2
										1.3
										2.1
										2.2
										2.3
										2.4
										2.5
										2.6
										1.1
										1.2
										1.3
										1.4
										1.5





- Product Finder
- V_C
- M
- MF
- UNC
- UNF
- G
- SELF-LOCK
- Tech. Info

	InnoForm H-SN PM-TIN-T26	InnoForm H-SN-IKZ PM-TIN-T26	InnoForm H-SN-IKZ-LF3 PM-TIN-T26	InnoForm H-SN-IKZN-LF3 PM-TIN-T26	InnoForm H-SN-IKZ-LF4 PM-TIN-T26	InnoForm H-SN-IKZN-LF4 PM-TIN-T26	InnoForm Z PM-TIN-80	InnoForm Z-SN PM-TIN-80
	C / 2-3	C / 2-3	C / 2-3	C / 2-3	C / 2-3	C / 2-3	C / 2-3	C / 2-3
Gewindetiefe und Lochform Thread depth and hole type	max. 3 x d ₁ 	max. 3 x d ₁ 	max. 3 x d ₁ 	max. 3 x d ₁ 	max. 4 x d ₁ 	max. 4 x d ₁ 	max. 3 x d ₁ 	max. 3 x d ₁
M	283, 289	283, 289	292	292	293	293	283, 289	283, 286, 289
MF	297	297						295, 297
UNC								299, 300
UNF								301, 302
G								303
SELF-LOCK								
Tech. Info								
UNEUF, UN-8								
G, Rp								
NPSM, NPSF								
NPT, NPTF, Rc								
W								
BSW, BSF								
Pg								
MJ								
UNJC, UNJF								
EG (STI)								
LK-M								
Tr, Tr-F, Rd								
P								
1.1							20 - 80	20 - 80
2.1	20 - 60	20 - 60	20 - 60	20 - 60	20 - 60	20 - 60	20 - 60	20 - 60
3.1	10 - 40	10 - 40	10 - 40	10 - 40	10 - 40	10 - 40	10 - 40	10 - 40
4.1	10 - 30	10 - 30	10 - 30	10 - 30	10 - 30	10 - 30	10 - 30	10 - 30
5.1	5 - 20	5 - 20	5 - 20	5 - 20	5 - 20	5 - 20	5 - 20	5 - 20
M								
1.1							10 - 25 ²⁾	10 - 25 ²⁾
2.1							10 - 25 ²⁾	10 - 25 ²⁾
3.1							5 - 20 ²⁾	5 - 20 ²⁾
4.1								
K								
1.1								
1.2								
2.1	20 - 60	20 - 60	20 - 60	20 - 60	20 - 60	20 - 60	20 - 60	20 - 60
2.2								
3.1								
3.2								
4.1								
4.2								
N								
1.1								
1.2								
1.3								
1.4								
1.5								
1.6								
2.1							20 - 40	20 - 40
2.2							40 - 80	40 - 80
2.3								
2.4							20 - 40	20 - 40
2.5							20 - 40	20 - 40
2.6								
2.7								
2.8								
3.1								
3.2								
4.1								
4.2								
4.3								
4.4								
5.1								
5.2								
5.3								
S								
1.1							5 - 20 ²⁾	5 - 20 ²⁾
1.2							5 - 15 ²⁾	5 - 15 ²⁾
1.3							5 - 10 ²⁾	5 - 10 ²⁾
2.1							5 - 10 ²⁾	5 - 10 ²⁾
2.2							5 - 10 ²⁾	5 - 10 ²⁾
2.3								
2.4							5 - 10 ²⁾	5 - 10 ²⁾
2.5								
2.6								
H								
1.1								
1.2								
1.3								
1.4								
1.5								

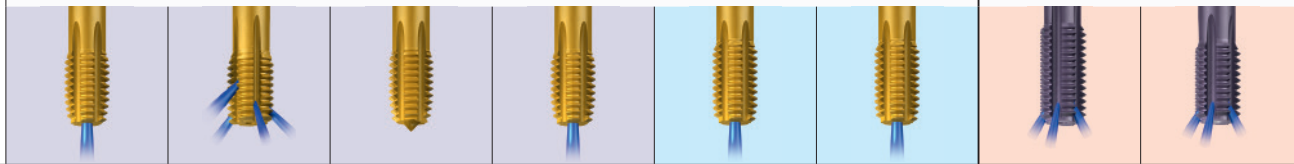
Seite . Page

V_C in m/min



InnoForm Z-SN-IKZ PM-TiN-80	InnoForm Z-SN-IKZN PM-TiN-80	InnoForm Z/E-SN PM-TiN-80	InnoForm Z/E-SN-IKZ PM-TiN-80	VHM-InnoForm Z-SN-IKZ TiN-80	VHM-InnoForm Z/E-SN-IKZ TiN-80	Drück GAL-SPEED/E SN-IKZN-TiCN	VHM-Drück GAL-SPEED/E SN-IKZN-TiCN
C / 2-3	C / 2-3	E / 1,5-2	E / 1,5-2	C / 2-3	E / 1,5-2	E / 1,5-2	E / 1,5-2
max. 3 x d ₁ 	max. 3 x d ₁ 			max. 3 x d ₁ 		max. 3 x d ₁ 	
283, 286, 289, 291 295, 297 299, 300 301, 302 303	283, 289	283, 289	283, 289	284	284	285, 290 295, 298	285, 290 295, 298



Gewindetiefe und Lochform
Thread depth and hole type

- M
- MF
- UNC
- UNF
- G
- SELF-LOCK
- Tech. Info
- BSW, BSF
- Pg
- MJ
- UNJC, UNJF
- EG (ST)
- LK-M
- Tr, Tr-F, Rd

Product Finder

v_c

M

MF

UNC

UNF

G

SELF-LOCK

Tech. Info

Seite . Page

20 - 80	20 - 80	20 - 80	20 - 80					1.1
20 - 60	20 - 60	20 - 60	20 - 60	20 - 60	20 - 60			2.1
10 - 40	10 - 40	10 - 40	10 - 40	10 - 40	10 - 40			3.1
10 - 30	10 - 30	10 - 30	10 - 30	10 - 30	10 - 30			4.1
5 - 20	5 - 20	5 - 20	5 - 20	5 - 20	5 - 20			5.1
10 - 25 ²⁾	10 - 25 ²⁾	10 - 25 ²⁾	10 - 25 ²⁾					1.1
10 - 25 ²⁾	10 - 25 ²⁾	10 - 25 ²⁾	10 - 25 ²⁾					2.1
5 - 20 ²⁾	5 - 20 ²⁾	5 - 20 ²⁾	5 - 20 ²⁾					3.1
								4.1
								1.1
20 - 60	20 - 60	20 - 60	20 - 60					1.2
								2.1
								2.2
								3.1
								3.2
								4.1
								4.2
								1.1
								1.2
								1.3
				20 - 80	20 - 80	20 - 80	40 - 160	1.4
				20 - 80	20 - 80	20 - 80	40 - 160	1.5
								1.6
20 - 40	20 - 40	20 - 40	20 - 40					2.1
40 - 80	40 - 80	40 - 80	40 - 80					2.2
								2.3
20 - 40	20 - 40	20 - 40	20 - 40	20 - 40	20 - 40	20 - 40		2.4
20 - 40	20 - 40	20 - 40	20 - 40	20 - 40	20 - 40	20 - 40		2.5
								2.6
								2.7
								2.8
								3.1
								3.2
								4.1
								4.2
								4.3
								4.4
								5.1
								5.2
								5.3
5 - 20 ²⁾	5 - 20 ²⁾	5 - 20 ²⁾	5 - 20 ²⁾					1.1
5 - 15 ²⁾	5 - 15 ²⁾	5 - 15 ²⁾	5 - 15 ²⁾					1.2
5 - 10 ²⁾	5 - 10 ²⁾	5 - 10 ²⁾	5 - 10 ²⁾					1.3
5 - 10 ²⁾	5 - 10 ²⁾	5 - 10 ²⁾	5 - 10 ²⁾					2.1
5 - 10 ²⁾	5 - 10 ²⁾	5 - 10 ²⁾	5 - 10 ²⁾					2.2
								2.3
5 - 10 ²⁾	5 - 10 ²⁾	5 - 10 ²⁾	5 - 10 ²⁾					2.4
								2.5
								2.6
								1.1
								1.2
								1.3
								1.4
								1.5



- Product Finder
- Vc
- M
- MF
- UNC
- UNF
- G
- SELF-LOCK
- Tech. Info

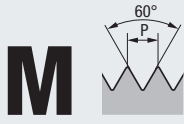

M
DIN 13

DIN 2174

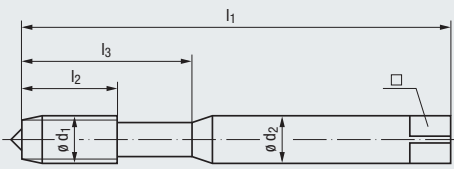

STEEL
Steel materials



Toleranz · Tolerance
Beschichtung · Coating
Schneidstoff · Cutting material

6HX	6HX	6HX	6HX	6HX
NT	CR	TIN	NT	CR
HSSE	HSSE	HSSE	HSSE	HSSE
C / 2-3	C / 2-3	C / 2-3	C / 2-3	C / 2-3
O / P	E / O	E / O / P	O / P	E / O

Technische Informationen
Technical information

» 305 - 324



Gewindetiefe und Lochform
Thread depth and hole type

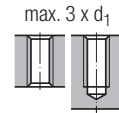

Einsatzgebiete – Material
Application – material

» 272

P 1.1-3.1	N 1.1-4, 2.1-2	P 1.1-3.1 M 1.1-2.1 2 N 1.4-5, 2.1-2	P 1.1-3.1	N 1.1-4, 2.1-2
-----------	----------------	--	-----------	----------------

Werkzeug-Ident · Tool ident

Ø d ₁ mm	P mm	l ₁	l ₂	l ₃	Ø d ₂	□	Image	Dimens.- Ident	B0911000	B0911300	B0911400	B0921000	B0921300
									Drück 1-STEEL NT	Drück 1-STEEL CR	Drück 1-STEEL TIN	Drück 1-STEEL-SN NT	Drück 1-STEEL-SN CR
M 1	0,25	40	5	–	2,5	2,1	0,9	.0010	● *)				
1,1	0,25	40	5	–	2,5	2,1	1	.0011	● *)				
1,2	0,25	40	5	–	2,5	2,1	1,1	.0012	● *)				
1,4	0,3	40	6	–	2,5	2,1	1,28	.0014	● *)				
1,6	0,35	40	6	11	2,5	2,1	1,47	.0016	●		●		
1,7	0,35	40	6	11	2,5	2,1	1,57	.0017	●				
1,8	0,35	40	6	11	2,5	2,1	1,67	.0018	●				
2	0,4	45	7	12	2,8	2,1	1,85	.0020	●	●	●	○	●
2,2	0,45	45	7	12	2,8	2,1	2,03	.0022	●			○	
2,3	0,4	45	7	12	2,8	2,1	2,15	.0023	●			○	
2,5	0,45	50	9	14	2,8	2,1	2,33	.0025	●	●	●	○	●
2,6	0,45	50	9	14	2,8	2,1	2,43	.0026	●		○	○	
3	0,5	56	11	18	3,5	2,7	2,8	.0030	●	●	●	○	●
3,5	0,6	56	12	20	4	3	3,25	.0035	●	●	●	○	
4	0,7	63	13	21	4,5	3,4	3,7	.0040	●	●	●	●	●
4,5	0,75	70	14	25	6	4,9	4,2	.0045	●	●	●	●	●
5	0,8	70	15	25	6	4,9	4,65	.0050	●	●	●	●	●
5,5	0,9	80	16	30	6	4,9	5,1	.0055	●	●	●	●	●
6	1	80	17	30	6	4,9	5,6	.0060	●	●	●	●	●
7	1	80	17	30	7	5,5	6,6	.0070	●		●	○	
8	1,25	90	20	35	8	6,2	7,45	.0080	●	●	●	●	●
9	1,25	90	20	35	9	7	8,45	.0090	●		●	●	●
10	1,5	100	22	39	10	8	9,35	.0100	●	●	●	●	●
12	1,75	110	24	44	12	9	11,25	.0112					

DIN 2174

» 272

*) ≤ M1,4 Tol. 4HX/5HX

Bei schlecht ausformenden Werkstoffen (z.B. GAL) empfehlen wir bei P ≥ 1 mm um 0,05 mm kleiner vorzubohren.
Weitere Informationen zu den empfohlenen Vorfertigungsdurchmessern siehe Seite 321.

We recommend a smaller preparatory diameter by 0.05 mm for difficult to form materials (such as aluminium cast alloys) for P ≥ 1 mm.
For further information regarding the recommended preparatory diameters, see page 321.

STEEL
Steel
materials

Product
Finder

V_c

M

MF

UNC

UNF

G

SELF-LOCK

Tech. Info

6HX		6GX		6HX		6HX		6HX		6HX	
TIN	VHM	TIN	TIN	TIN	TIN-66	TIN-66	TIN-66	TIN	TIN	TICN-67	TICN-67
HSSE		HSSE	HSSE	HSSE-PM	HSSE-PM	HSSE-PM	HSSE-PM	HSSE-PM	HSSE-PM	HSSE-PM	HSSE-PM
C / 2-3	C / 2-3	C / 2-3	C / 2-3	D / 4-5	C / 2-3	C / 2-3	E / 1,5-2	C / 2-3	C / 2-3	C / 2-3	C / 2-3
E / O / P	E / O	E / O / P	E / O / P	E / O / P	E / O / P	E / O	E / O	E / O / P	E / O / P	E / O	E / O
max. 3 x d ₁	max. 3 x d ₁	max. 3 x d ₁		max. 3 x d ₁	max. 3 x d ₁	max. 3 x d ₁		max. 3 x d ₁	max. 3 x d ₁	max. 3 x d ₁	max. 3 x d ₁
P 1.1-3.1	P 2.1-4.1	P 1.1-3.1	P 1.1-3.1	P 1.1-4.1	P 1.1-4.1	P 1.1-4.1	P 1.1-4.1	P 3.1-5.1	P 3.1-5.1	P 3.1-5.1	P 3.1-5.1
M 1.1-2.1 2)	N 1.4-5	M 1.1-2.1 2)	M 1.1-2.1 2)		K 2.1	K 2.1	K 2.1	K 2.1	K 2.1	K 2.1	K 2.1
N 1.4-5, 2.1-2		N 1.4-5, 2.1-2	N 1.4-5, 2.1-2								
B0921400	B1970100	B0911420	B0921420	B535P300	B5217F00	B5237F00	B5317F00	B5216F00	B5236F00		
Drück 1-STEEL-SN TIN	VHM Drück 1-STEEL SN-IKZ	Drück 1-STEEL TIN „6GX“	Drück 1-STEEL-SN TIN „6GX“	InnoForm 1-STEEL-BL/D PM-TIN	InnoForm 1-STEEL-M SN-PM TIN-66	InnoForm 1-STEEL-M SN-IKZ-PM TIN-66	InnoForm 1-STEEL-M/E SN-IKZ-PM TIN-66	InnoForm 1-STEEL-H SN-PM TICN-67	InnoForm 1-STEEL-H SN-PM TICN-67		
										M	1
											1,1
											1,2
											1,4
											1,6
											1,7
											1,8
●		●	●								2
											2,2
●		●	●								2,3
○		○	○	●	●						2,5
●		●	●								2,6
●		●	●								3
●		●	●								3,5
●		●	●	●	●			●	●		4
●	●	●	●	●	●	●	●	●	●		4,5
●	●	●	●	●	●	●	●	●	●		5
●	●	●	●	●	●	●	●	●	●		5,5
●	●	●	●	●	●	●	●	●	●		6
●	●	●	●	●	●	●	●	●	●		7
●	●	●	●	●	●	●	●	●	●		8
●	●	●	●	●	●	●	●	●	●		9
●	●	●	●	●	●	●	●	●	●		10
											12
📄 287					📄 287	📄 287	📄 287	📄 288	📄 288		

1) Gewindeformen in Durchgangslöcher nur mit externer Kühlschmierung möglich
Cold-forming in through holes is possible only with external cooling/lubrication

2) Mit Emulsion nur bedingt einsetzbar
Restricted application possibilities with emulsion

3) Zum Patent angemeldet
Patent pending

- Product Finder
- Vc
- M
- MF
- UNC
- UNF
- G
- SELF-LOCK
- Tech. Info

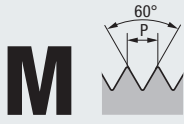

M
DIN 13

DIN 2174

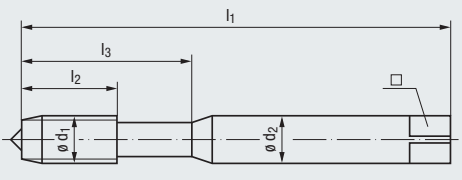

Technische Informationen Technical information	Toleranz · Tolerance Beschichtung · Coating Schneidstoff · Cutting material	6HX	6HX	6HX
		TICN-67	TIN-T26	TIN-T26
Technische Informationen Technical information	Schneidstoff · Cutting material	HSSE-PM	HSSE-PM	HSSE-PM
		E / 1,5-2	E / 1,5-2	E / 1,5-2
		E / 0	E / 0 / P	E / 0

Gewindetiefe und Lochform Thread depth and hole type	max. 3 x d ₁	max. 3 x d ₁	max. 3 x d ₁

Einsatzgebiete – Material Application – material	P 3.1-5.1 K 2.1	P 1.1-4.1 M 1.1-3.1 2)	P 1.1-4.1 M 1.1-3.1 2)
---	--------------------	---------------------------	---------------------------



















Werkzeug-Ident · Tool ident										B5316F00	B5296A00	B5316A00
Ø d ₁ mm	P mm	l ₁	l ₂	l ₃	Ø d ₂	□		Dimens.- Ident	InnoForm 1-STEEL-H/E SN-IKZ-PM TICN-67	InnoForm 1-VA/E-SN PM-TIN-T26	InnoForm 1-VA/E-SN IKZ-PM TIN-T26	
M 1	0,25	40	2,5	–	2,5	2,1	0,9	.0010				
1,1	0,25	40	2,5	–	2,5	2,1	1	.0011				
1,2	0,25	40	2,5	–	2,5	2,1	1,1	.0012				
1,4	0,3	40	3	–	2,5	2,1	1,28	.0014				
1,6	0,35	40	4	11	2,5	2,1	1,47	.0016				
1,7	0,35	40	4	11	2,5	2,1	1,57	.0017				
1,8	0,35	40	4	11	2,5	2,1	1,67	.0018				
2	0,4	45	4	12	2,8	2,1	1,85	.0020				
2,2	0,45	45	4,5	12	2,8	2,1	2,03	.0022				
2,3	0,4	45	4,5	12	2,8	2,1	2,15	.0023				
2,5	0,45	50	5	14	2,8	2,1	2,33	.0025				
2,6	0,45	50	5	14	2,8	2,1	2,43	.0026				
3	0,5	56	6	18	3,5	2,7	2,8	.0030		•		
3,5	0,6	56	7	20	4	3	3,25	.0035				
4	0,7	63	7	21	4,5	3,4	3,7	.0040	•	•	•	
4,5	0,75	70	8	25	6	4,9	4,2	.0045				
5	0,8	70	8	25	6	4,9	4,65	.0050	•	•	•	
5,5	0,9	80	10	30	6	4,9	5,1	.0055				
6	1	80	10	30	6	4,9	5,6	.0060	•	•	•	
7	1	80	10	30	7	5,5	6,6	.0070				
8	1,25	90	14	35	8	6,2	7,45	.0080	•	•	•	
9	1,25	90	14	35	9	7	8,45	.0090				
10	1,5	100	16	39	10	8	9,35	.0100	•	•	•	
12	1,75	110	18	44	12	9	11,25	.0112				

DIN 2174 288

1) Gewindeformen in Durchgangslöcher nur mit externer Kühlschmierung möglich
Cold-forming in through holes is possible only with external cooling/lubrication

2) Mit Emulsion nur bedingt einsetzbar
Restricted application possibilities with emulsion

3) Zum Patent angemeldet
Patent pending

AL Aluminium wrought alloys					GAL Aluminium cast alloys				
									
6HX	6HX	6HX	6HX	6HX	6HX	6HX	6HX	6HX	
GLT-8	GLT-8	GLT-8	GLT-8	GLT-8	TICN	TICN	TICN	TICN	
HSSE-PM	HSSE-PM	HSSE-PM	HSSE-PM	HSSE-PM	HSSE-PM	HSSE-PM	HSSE-PM	HSSE-PM	
C / 2-3	C / 2-3	C / 2-3	E / 1,5-2	E / 1,5-2	C / 2-3	C / 2-3	C / 2-3	C / 2-3	
E / O / P	E / O / P	E / O	E / O / P	E / O	E / O / P	E / O / P	E / O	E / O	
max. 3 x d ₁		max. 3 x d ₁		max. 3 x d ₁		max. 3 x d ₁		max. 3 x d ₁	
									
N 1.1-4, 2.1-2	N 1.1-4, 2.1-2	N 1.1-4, 2.1-2	N 1.1-4, 2.1-2	N 1.1-4, 2.1-2	N 1.4-6	N 1.4-6	N 1.4-6	N 1.4-6	
B519Y700	B521Y700	B523Y700	B529Y700	B531Y700	B519Q200	B521Q200	B523Q200	B526Q200	
InnoForm 1-AL-PM GLT-8	InnoForm 1-AL-SN-PM GLT-8	InnoForm 1-AL-SN-PM-GLT-8	InnoForm 1-AL/E-SN PM-GLT-8	InnoForm 1-AL/E-SN IKZ-PM GLT-8	InnoForm 1-GAL-PM TICN	InnoForm 1-GAL-SN PM-TICN	InnoForm 1-GAL-SN IKZ-PM-TICN	InnoForm 1-GAL-SN IKZN-PM TICN	
○ *)									
○ *)									
○ *)									
○	○								
●	●		●						
●	●		●						
●	●		●						
●	●	●	●	●					
●	●		●						
●	●	●	●	●	●	●	●	○	
●	●	●	●	●	●	●	●	○	
●	●	●	●	●	●	●	●	○	
●	●	●	●	●	●	●	●	○	



*) ≤ M1,4 Tol. 4HX/5HX

Bei schlecht ausformenden Werkstoffen (z.B. GAL) empfehlen wir bei P ≥ 1 mm um 0,05 mm kleiner vorzubohren. Weitere Informationen zu den empfohlenen Vorfertigungsdurchmessern siehe Seite 321.

We recommend a smaller preparatory diameter by 0.05 mm for difficult to form materials (such as aluminium cast alloys) for P ≥ 1 mm. For further information regarding the recommended preparatory diameters, see page 321.

- Product Finder
- Vc
- M
- MF
- UNC
- UNF
- G
- SELF-LOCK
- Tech. Info

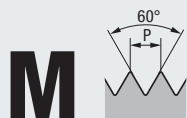

DIN 13

DIN 2174

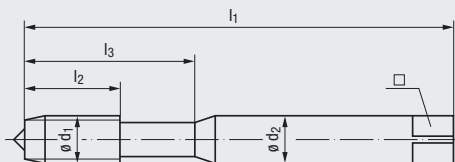

GAL
Aluminium
cast alloys



Technische Informationen Technical information	Toleranz · Tolerance Beschichtung · Coating Schneidstoff · Cutting material	6HX	6HX	6HX
		TICN	TICN	TICN
Technische Informationen Technical information	Schneidstoff · Cutting material	HSSE-PM	HSSE-PM	HSSE-PM
		E / 1,5-2	E / 1,5-2	E / 1,5-2
		E / O / P	E / O	E / O

Gewindetiefe und Lochform Thread depth and hole type	max. 3 x d ₁	max. 3 x d ₁	max. 3 x d ₁

Einsatzgebiete – Material Application – material	N 1.4-6	N 1.4-6	N 1.4-6
---	---------	---------	---------

Werkzeug-Ident · Tool ident										B529Q200	B531Q200	B533Q200
Ø d ₁ mm	P mm	l ₁	l ₂	l ₃	Ø d ₂	□		Dimens.- Ident	InnoForm 1-GAL/E-SN PM-TICN	InnoForm 1-GAL/E-SN IKZ-PM-TICN	InnoForm 1-GAL/E-SN IKZN-PM TICN	
M 2	0,4	45	4	12	2,8	2,1	1,85	.0020				
2,2	0,45	45	4,5	12	2,8	2,1	2,03	.0022				
2,3	0,4	45	4,5	12	2,8	2,1	2,15	.0023				
2,5	0,45	50	5	14	2,8	2,1	2,33	.0025				
2,6	0,45	50	5	14	2,8	2,1	2,43	.0026				
3	0,5	56	6	18	3,5	2,7	2,8	.0030				
3,5	0,6	56	7	20	4	3	3,25	.0035				
4	0,7	63	7	21	4,5	3,4	3,7	.0040				
4,5	0,75	70	8	25	6	4,9	4,2	.0045				
5	0,8	70	8	25	6	4,9	4,65	.0050	●	●	○	
5,5	0,9	80	10	30	6	4,9	5,1	.0055				
6	1	80	10	30	6	4,9	5,6	.0060	●	●	○	
7	1	80	10	30	7	5,5	6,6	.0070				
8	1,25	90	14	35	8	6,2	7,45	.0080	●	●	○	
9	1,25	90	14	35	9	7	8,45	.0090				
10	1,5	100	16	39	10	8	9,35	.0100	●	●	○	
12	1,75	110	18	44	12	9	11,25	.0112				































1) Gewindeformen in Durchgangslöcher nur mit externer Kühlschmierung möglich
 Cold-forming in through holes is possible only with external cooling/lubrication

Bei schlecht ausformenden Werkstoffen (z.B. GAL) empfehlen wir bei P ≥ 1 mm um 0,05 mm kleiner vorzubohren.
 Weitere Informationen zu den empfohlenen Vorfertigungsdurchmessern siehe Seite 321.

We recommend a smaller preparatory diameter by 0.05 mm for difficult to form materials (such as aluminium cast alloys) for P ≥ 1 mm.
 For further information regarding the recommended preparatory diameters, see page 321.

- Product Finder
- Vc
- M
- MF
- UNC
- UNF
- G
- SELF-LOCK
- Tech. Info

H Materials of high tensile strength		Z CNC-controlled machines							
									
6HX	6HX	6HX	6HX	6HX	6HX	6HX	6HX	6HX	6GX
TIN-T26	TIN-T26	TIN-80	TIN-80	TIN-80	TIN-80	TIN-80	TIN-80	TIN-80	TIN-80
HSSE-PM	HSSE-PM	HSSE-PM	HSSE-PM	HSSE-PM	HSSE-PM	HSSE-PM	HSSE-PM	HSSE-PM	HSSE-PM
C / 2-3	C / 2-3	C / 2-3	C / 2-3	C / 2-3	C / 2-3	E / 1,5-2	E / 1,5-2	E / 1,5-2	C / 2-3
E / O / P	E / O	E / O / P	E / O / P	E / O	E / O	E / O / P	E / O	E / O	E / O / P
max. 3 x d ₁	max. 3 x d ₁	max. 3 x d ₁	max. 3 x d ₁	max. 3 x d ₁	max. 3 x d ₁	max. 3 x d ₁	max. 3 x d ₁	max. 3 x d ₁	max. 3 x d ₁
									
P 2.1-5.1	P 2.1-5.1	P 1.1-5.1	P 1.1-5.1	P 1.1-5.1	P 1.1-5.1	P 1.1-5.1	P 1.1-5.1	P 1.1-5.1	P 1.1-5.1
K 2.1	K 2.1	K 2.1	K 2.1	K 2.1	K 2.1	K 2.1	K 2.1	K 2.1	K 2.1
		M 1.1-3.1 ²⁾	M 1.1-3.1 ²⁾	M 1.1-3.1 ²⁾	M 1.1-3.1 ²⁾	M 1.1-3.1 ²⁾	M 1.1-3.1 ²⁾	M 1.1-3.1 ²⁾	M 1.1-3.1 ²⁾
		N 2.1-2, 2.4-5	N 2.1-2, 2.4-5	N 2.1-2, 2.4-5	N 2.1-2, 2.4-5	N 2.1-2, 2.4-5	N 2.1-2, 2.4-5	N 2.1-2, 2.4-5	N 2.1-2, 2.4-5
		S 1.1-2.2 ²⁾	S 1.1-2.2 ²⁾	S 1.1-2.2 ²⁾	S 1.1-2.2 ²⁾	S 1.1-2.2 ²⁾	S 1.1-2.2 ²⁾	S 1.1-2.2 ²⁾	S 1.1-2.2 ²⁾
		S 2.4 ²⁾	S 2.4 ²⁾	S 2.4 ²⁾	S 2.4 ²⁾	S 2.4 ²⁾	S 2.4 ²⁾	S 2.4 ²⁾	S 2.4 ²⁾
B521W700	B523W700	B519Z700	B521Z700	B523Z700	B526Z700	B529Z700	B531Z700	B521Z720	
InnoForm 1-H-SN-PM TIN-T26	InnoForm 1-H-SN- IKZ PM-TIN-T26	InnoForm 1-Z-PM TIN-80	InnoForm 1-Z-SN-PM TIN-80	InnoForm 1-Z-SN- IKZ PM-TIN-80	InnoForm 1-Z-SN- IKZN PM-TIN-80	InnoForm 1-Z/E-SN PM-TIN-80	InnoForm 1-Z/E-SN- IKZ PM-TIN-80	InnoForm 1-Z-SN-PM TIN-80 „6GX“	
		○	○						M
									2
									2,2
		○	○						2,3
									2,5
		●	●			●		●	2,6
									3
		●	●	●	○	●	●	●	3,5
									4
●	●	●	●	●	○	●	●	●	4,5
									5
●	●				○	●	●	●	5,5
									6
●	●	●	●	●	○	●	●	●	7
									8
●	●	●	●	●	○	●	●	●	9
									10
		●	●	●	○	●	●	●	12
									

²⁾ Mit Emulsion nur bedingt einsetzbar
Restricted application possibilities with emulsion



Spannzangen-Aufnahmen mit integrierter Übersetzung der Typenreihe Speedsynchro® Modular siehe Seite 683 - 686

Collet holders with integrated transmission of our Speedsynchro® Modular series, see page 683 - 686

- Product Finder
- Vc
- M
- MF
- UNC
- UNF
- G
- SELF-LOCK
- Tech. Info

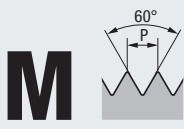

DIN 13

DIN 2174

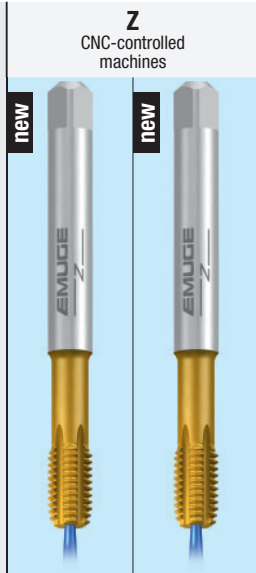
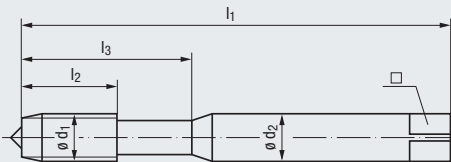

Toleranz · Tolerance
Beschichtung · Coating
Schneidstoff · Cutting material

Technische Informationen
Technical information

» 305 - 324

6HX	6HX
TIN-80	TIN-80
VHM	VHM
C / 2-3	E / 1,5-2
E / 0	E / 0

Gewindetiefe und Lochform
Thread depth and hole type

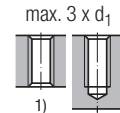

Einsatzgebiete – Material
Application – material

» 272

P 2.1-5.1	P 2.1-5.1
N 1.4-5, 2.4-5	N 1.4-5, 2.4-5

Werkzeug-Ident · Tool ident

B523Z800 B531Z800

M	Ø d ₁ mm	P mm	l ₁	l ₂	l ₃	Ø d ₂	□	Image	Dimens.- Ident	VHM InnoForm	
										1-Z-SN- IKZ TIN-80	1-Z/E-SN- IKZ TIN-80
	2	0,4	45	4	12	2,8	2,1	1,85	.0020		
	2,2	0,45	45	4,5	12	2,8	2,1	2,03	.0022		
	2,3	0,4	45	4,5	12	2,8	2,1	2,15	.0023		
	2,5	0,45	50	5	14	2,8	2,1	2,33	.0025		
	2,6	0,45	50	5	14	2,8	2,1	2,43	.0026		
	3	0,5	56	6	18	3,5	2,7	2,8	.0030		
	3,5	0,6	56	7	20	4	3	3,25	.0035		
	4	0,7	63	7	21	4,5	3,4	3,7	.0040		
	4,5	0,75	70	8	25	6	4,9	4,2	.0045		
	5	0,8	70	8	25	6	4,9	4,65	.0050	•	•
	5,5	0,9	80	10	30	6	4,9	5,1	.0055		
	6	1	80	10	30	6	4,9	5,6	.0060	•	•
	7	1	80	10	30	7	5,5	6,6	.0070		
	8	1,25	90	14	35	8	6,2	7,45	.0080	•	•
	9	1,25	90	14	35	9	7	8,45	.0090		
	10	1,5	100	16	39	10	8	9,35	.0100	•	•
	12	1,75	110	18	44	12	9	11,25	.0112		

1) Gewindeformen in Durchgangslöcher nur mit externer Kühlschmierung möglich
Cold-forming in through holes is possible only with external cooling/lubrication



Bei schlecht ausformenden Werkstoffen (z.B. GAL) empfehlen wir bei P ≥ 1 mm um 0,05 mm kleiner vorzubohren.
Weitere Informationen zu den empfohlenen Vorfertigungsdurchmessern siehe Seite 321.

We recommend a smaller preparatory diameter by 0.05 mm for difficult to form materials (such as aluminium cast alloys) for P ≥ 1 mm.
For further information regarding the recommended preparatory diameters, see page 321.



DIN 13

DIN 2174

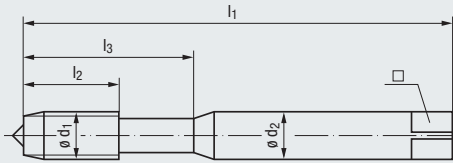

SPEED
High-speed cutting

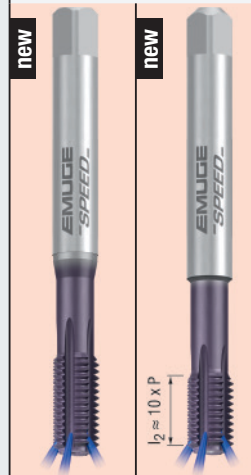

- Product Finder
- Vc
- M
- MF
- UNC
- UNF
- G
- SELF-LOCK
- Tech. Info

Technische Informationen
Technical information

» 305 - 324

Toleranz · Tolerance
Beschichtung · Coating
Schneidstoff · Cutting material



6HX	6HX
TICN	TICN
HSSE	VHM
E / 1,5-2	E / 1,5-2
E / 0	E / 0

Gewindetiefe und Lochform
Thread depth and hole type

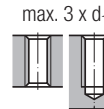

Einsatzgebiete – Material
Application – material

» 272

N 1.4-5 N 1.4-5

Werkzeug-Ident · Tool ident

B5059500 B505Q800

M	ø d ₁ mm	P mm	l ₁	l ₂	l ₃	ø d ₂	□		Dimens.- Ident	Drück	VHM-Drück
										1-GAL	1-GAL
										SPEED/E-SN	SPEED/E-SN
										IKZN-TICN	IKZN-TICN
	2	0,4	45	7	12	2,8	2,1	1,85	.0020		
	2,2	0,45	45	7	12	2,8	2,1	2,03	.0022		
	2,3	0,4	45	7	12	2,8	2,1	2,15	.0023		
	2,5	0,45	50	9	14	2,8	2,1	2,33	.0025		
	2,6	0,45	50	9	14	2,8	2,1	2,43	.0026		
	3	0,5	56	11	18	3,5	2,7	2,8	.0030		
	3,5	0,6	56	12	20	4	3	3,25	.0035		
	4	0,7	63	13	21	4,5	3,4	3,7	.0040	○	○
	4,5	0,75	70	14	25	6	4,9	4,2	.0045		
	5	0,8	70	15	25	6	4,9	4,65	.0050	○	○
	5,5	0,9	80	16	30	6	4,9	5,1	.0055		
	6	1	80	17	30	6	4,9	5,6	.0060	○	○
	7	1	80	17	30	7	5,5	6,6	.0070		
	8	1,25	90	20	35	8	6,2	7,45	.0080	○	○
	9	1,25	90	20	35	9	7	8,45	.0090		
	10	1,5	100	22	39	10	8	9,35	.0100	○	○
	12	1,75	110	24	44	12	9	11,25	.0112		

DIN 2174

» 290 » 290



Bei schlecht ausformenden Werkstoffen (z.B. GAL) empfehlen wir bei P ≥ 1 mm um 0,05 mm kleiner vorzubohren.
Weitere Informationen zu den empfohlenen Vorfertigungsdurchmessern siehe Seite 321.

We recommend a smaller preparatory diameter by 0.05 mm for difficult to form materials (such as aluminium cast alloys) for P ≥ 1 mm.
For further information regarding the recommended preparatory diameters, see page 321.

● = Lagerwerkzeug, siehe Preisliste · Stock tool, see price list
○ = Kurzfristig lieferbar, Preis auf Anfrage · Available on short notice, price upon inquiry

- Product Finder
- Vc
- M**
- MF
- UNC
- UNF
- G
- SELF-LOCK
- Tech. Info

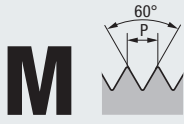

DIN 13

Mit extra langem Schaft
With extra long shank

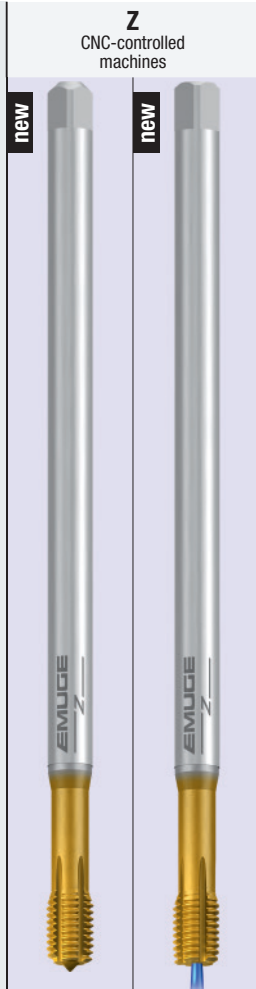
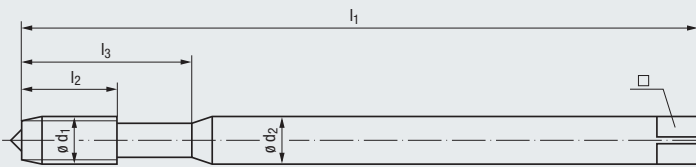

Technische Informationen Technical information	▶ 305 - 324	Toleranz · Tolerance	6HX	6HX
		Beschichtung · Coating	TIN-80	TIN-80
Gewindetiefe und Lochform Thread depth and hole type	▶ 272	Schneidstoff · Cutting material	HSSE-PM	HSSE-PM
			C / 2-3	C / 2-3
			E / O / P	E / O
			max. 3 x d ₁	max. 3 x d ₁

Werkzeug-Ident · Tool ident										B555Z700	B544Z700
ø d ₁ mm	P mm	l ₁	l ₂	l ₃	ø d ₂	□		Dimens.- Ident		InnoForm 1-Z-SN-LS PM-TIN-80	InnoForm 1-Z-SN- LS-PM TIN-80
M 3	0,5	100	6	18	3,5	2,7	2,8	.0030	●	●	
4	0,7	125	7	21	4,5	3,4	3,7	.0040	●		
5	0,8	140	8	25	6	4,9	4,65	.0050	●	○	
6	1	160	10	30	6	4,9	5,6	.0060	●	○	
8	1,25	180	14	35	8	6,2	7,45	.0080	●	○	
10	1,5	200	16	39	10	8	9,35	.0100	●	○	



291 291

1) Gewindeformen in Durchgangslöcher nur mit externer Kühlschmierung möglich
Cold-forming in through holes is possible only with external cooling/lubrication

2) Mit Emulsion nur bedingt einsetzbar
Restricted application possibilities with emulsion



Bei schlecht ausformenden Werkstoffen (z.B. GAL) empfehlen wir bei P ≥ 1 mm um 0,05 mm kleiner vorzubohren.
Weitere Informationen zu den empfohlenen Vorfertigungsdurchmessern siehe Seite 321.

We recommend a smaller preparatory diameter by 0.05 mm for difficult to form materials (such as aluminium cast alloys) for P ≥ 1 mm.
For further information regarding the recommended preparatory diameters, see page 321.

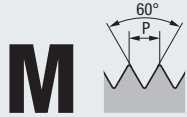

DIN 13

DIN 2174

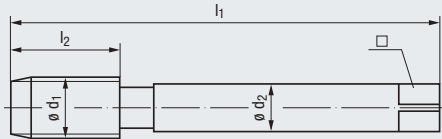

Technische Informationen
Technical information

» 305 - 324

Toleranz · Tolerance
Beschichtung · Coating
Schneidstoff · Cutting material



Gewindetiefe und Lochform
Thread depth and hole type

Einsatzgebiete – Material
Application – material

» 272

Werkzeug-Ident · Tool ident

M	Ø d ₁ mm	P mm	l ₁	l ₂	Ø d ₂	□	 Dimens.- Ident	Drück	Drück	InnoForm	InnoForm	InnoForm	
								2-STEEL TIN	2-STEEL-SN TIN	2-STEEL-M SN-PM TIN-66	2-STEEL-M SN- IKZ -PM TIN-66	2-STEEL-M/E SN- IKZ -PM TIN-66	
	10	1,5	100	22	7	5,5	9,35	.0100					
	12	1,75	110	24	9	7	11,25	.0112					
	14	2	110	26	11	9	13,1	.0114					
	16	2	110	27	12	9	15,1	.0116					
	18	2,5	125	30	14	11	16,85	.0118					
	20	2,5	140	32	16	12	18,85	.0120					
	22	2,5	140	32	18	14,5	20,85	.0122					
	24	3	160	34	18	14,5	22,6	.0124					
	27	3	160	36	20	16	25,6	.0127					
	30	3,5	180	40	22	18	28,35	.0130					
	33	3,5	180	40	25	20	31,35	.0133					
	36	4	200	50	28	22	34,1	.0136					
	39	4	200	50	32	24	37,1	.0139					
	42	4,5	200	56	32	24	39,85	.0142					
	45	4,5	220	58	36	29	42,85	.0145					
	48	5	250	65	36	29	45,65	.0148					

DIN 2174



» 278

» 279

» 279

» 279

» 279

1) Gewindeformen in Durchgangslöchern nur mit externer Kühlschmierung möglich
Cold-forming in through holes is possible only with external cooling/lubrication

2) Mit Emulsion nur bedingt einsetzbar
Restricted application possibilities with emulsion

3) Zum Patent angemeldet
Patent pending



Bei schlecht ausformenden Werkstoffen (z.B. GAL) empfehlen wir bei P ≥ 1 mm um 0,05 mm kleiner vorzubohren.

Weitere Informationen zu den empfohlenen Vorfertigungsdurchmessern siehe Seite 321.

We recommend a smaller preparatory diameter by 0.05 mm for difficult to form materials (such as aluminium cast alloys) for P ≥ 1 mm.

For further information regarding the recommended preparatory diameters, see page 321.



- Product Finder
- Vc
- M
- MF
- UNC
- UNF
- G
- SELF-LOCK
- Tech. Info

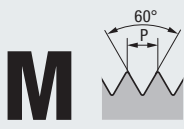

DIN 13

DIN 2174

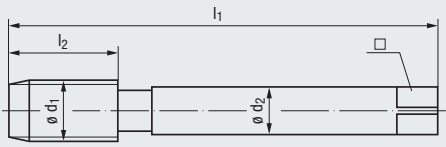

Toleranz · Tolerance
Beschichtung · Coating
Schneidstoff · Cutting material

Technische Informationen
Technical information

» 305 - 324

6HX	6HX	6HX
TICN-67	TICN-67	TICN-67
HSSE-PM	HSSE-PM	HSSE-PM
C / 2-3	C / 2-3	E / 1,5-2
E / O / P	E / O	E / O

Gewindetiefe und Lochform
Thread depth and hole type

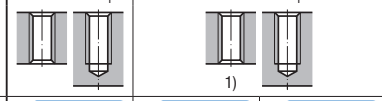

Einsatzgebiete – Material
Application – material

» 272

P 3.1-5.1	P 3.1-5.1	P 3.1-5.1
K 2.1	K 2.1	K 2.1

Werkzeug-Ident · Tool ident

C5216F00 C5236F00 C5316F00

M	Ø d ₁ mm	P mm	l ₁	l ₂	Ø d ₂	□	Image	Dimens.- Ident	InnoForm	InnoForm	InnoForm
									2-STEEL-H SN-PM TICN-67	2-STEEL-H SN-IKZ-PM TICN-67	2-STEEL-H/E SN-IKZ-PM TICN-67
	10	1,5	100	16	7	5,5	9,35	.0100			
	12	1,75	110	18	9	7	11,25	.0112	•	•	•
	14	2	110	20	11	9	13,1	.0114			
	16	2	110	22	12	9	15,1	.0116	•	•	•
	18	2,5	125	25	14	11	16,85	.0118			
	20	2,5	140	25	16	12	18,85	.0120			
	22	2,5	140	27	18	14,5	20,85	.0122			
	24	3	160	30	18	14,5	22,6	.0124			
	27	3	160	30	20	16	25,6	.0127			
	30	3,5	180	35	22	18	28,35	.0130			
	33	3,5	180	35	25	20	31,35	.0133			
	36	4	200	40	28	22	34,1	.0136			
	39	4	200	40	32	24	37,1	.0139			
	42	4,5	200	45	32	24	39,85	.0142			
	45	4,5	220	45	36	29	42,85	.0145			
	48	5	250	50	36	29	45,65	.0148			

DIN 2174 279 279 280

1) Gewindeformen in Durchgangslöcher nur mit externer Kühlschmierung möglich
Cold-forming in through holes is possible only with external cooling/lubrication

3) Zum Patent angemeldet
Patent pending

Bei schlecht ausformenden Werkstoffen (z.B. GAL) empfehlen wir bei P ≥ 1 mm um 0,05 mm kleiner vorzubohren.
Weitere Informationen zu den empfohlenen Vorfertigungsdurchmessern siehe Seite 321.

We recommend a smaller preparatory diameter by 0.05 mm for difficult to form materials (such as aluminium cast alloys) for P ≥ 1 mm.
For further information regarding the recommended preparatory diameters, see page 321.

- Product Finder
- Vc
- M
- MF
- UNC
- UNF
- G
- SELF-LOCK
- Tech. Info

H Materials of high tensile strength		Z CNC-controlled machines							
6HX	6HX	6HX	6HX	6HX	6HX	6HX	6HX	6HX	6HX
TIN-T26	TIN-T26	TIN-80	TIN-80	TIN-80	TIN-80	TIN-80	TIN-80	TIN-80	TIN-80
HSSE-PM	HSSE-PM	HSSE-PM	HSSE-PM	HSSE-PM	HSSE-PM	HSSE-PM	HSSE-PM	HSSE-PM	HSSE-PM
C / 2-3	C / 2-3	C / 2-3	C / 2-3	C / 2-3	C / 2-3	C / 2-3	E / 1,5-2	E / 1,5-2	E / 1,5-2
E / O	E	E / O / P	E / O / P	E / O	E / O	E / O	E / O / P	E / O	E / O
max. 3 x d ₁	max. 3 x d ₁	max. 3 x d ₁	max. 3 x d ₁	max. 3 x d ₁	max. 3 x d ₁	max. 3 x d ₁	max. 3 x d ₁	max. 3 x d ₁	max. 3 x d ₁
P 2.1-5.1	P 2.1-5.1	P 1.1-5.1	P 1.1-5.1	P 1.1-5.1	P 1.1-5.1	P 1.1-5.1	P 1.1-5.1	P 1.1-5.1	P 1.1-5.1
K 2.1	K 2.1	M 1.1-3.1 ²⁾	M 1.1-3.1 ²⁾	M 1.1-3.1 ²⁾	M 1.1-3.1 ²⁾	M 1.1-3.1 ²⁾	M 1.1-3.1 ²⁾	M 1.1-3.1 ²⁾	M 1.1-3.1 ²⁾
		K 2.1	K 2.1	K 2.1	K 2.1	K 2.1	K 2.1	K 2.1	K 2.1
		N 2.1-2, 2.4-5	N 2.1-2, 2.4-5	N 2.1-2, 2.4-5	N 2.1-2, 2.4-5	N 2.1-2, 2.4-5	N 2.1-2, 2.4-5	N 2.1-2, 2.4-5	N 2.1-2, 2.4-5
		S 1.1-2.2 ²⁾	S 1.1-2.2 ²⁾	S 1.1-2.2 ²⁾	S 1.1-2.2 ²⁾	S 1.1-2.2 ²⁾	S 1.1-2.2 ²⁾	S 1.1-2.2 ²⁾	S 1.1-2.2 ²⁾
		S 2.4 ²⁾	S 2.4 ²⁾	S 2.4 ²⁾	S 2.4 ²⁾	S 2.4 ²⁾	S 2.4 ²⁾	S 2.4 ²⁾	S 2.4 ²⁾
C521W700	C523W700	C519Z700	C521Z700	C523Z700	C526Z700	C529Z700	C531Z700		
InnoForm 2-H-SN-PM TIN-T26	InnoForm 2-H-SN-PM PM-TIN-T26	InnoForm 2-Z-PM TIN-80	InnoForm 2-Z-SN-PM TIN-80	InnoForm 2-Z-SN-PM PM-TIN-80	InnoForm 2-Z-SN-PM PM-TIN-80	InnoForm 2-Z-SN-PM PM-TIN-80	InnoForm 2-Z-SN-PM PM-TIN-80	InnoForm 2-Z-SN-PM PM-TIN-80	
●	●	●	●	●	○	●	●		M 10
		●	●	●	○	●	●		12
		●	●	●	○	●	●		14
									16
			●	●					18
					○				20
									22
									24
									27
									30
									33
									36
									39
									42
									45
									48
📄 283	📄 283	📄 283	📄 283	📄 283	📄 283	📄 283	📄 283	📄 283	

²⁾ Mit Emulsion nur bedingt einsetzbar
Restricted application possibilities with emulsion

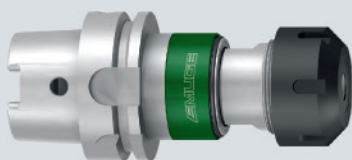

Werkzeug-Aufnahmen für
Minimalmengenschmierung
siehe Seite 714 - 732

Tool holders for
minimum-quantity lubrication,
see page 714 - 732

- Product Finder
- Vc
- M
- MF
- UNC
- UNF
- G
- SELF-LOCK
- Tech. Info

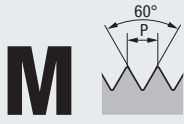

DIN 13

DIN 2174

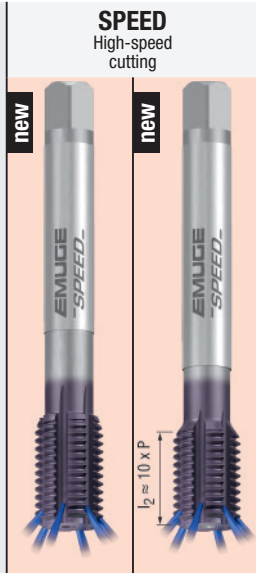
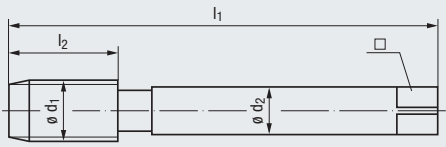

Toleranz · Tolerance
Beschichtung · Coating
Schneidstoff · Cutting material

Technische Informationen
Technical information

» 305 - 324

- | | |
|-----------|-----------|
| 6HX | 6HX |
| TICN | TICN |
| HSSE | VHM |
| E / 1,5-2 | E / 1,5-2 |
| E / 0 | E / 0 |

Gewindetiefe und Lochform
Thread depth and hole type

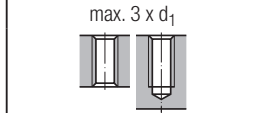

Einsatzgebiete – Material
Application – material

» 272

N 1.4-5

Werkzeug-Ident · Tool ident

C5059500 C505Q800

M	Ø d ₁ mm	P mm	l ₁	l ₂	Ø d ₂	□	Image	Dimens.- Ident	Drück	VHM-Drück
									2-GAL SPEED/E-SN IKZN-TICN	2-GAL SPEED/E-SN IKZN-TICN
	10	1,5	100	22	7	5,5	9,35	.0100		
	12	1,75	110	24	9	7	11,25	.0112	○	○
	14	2	110	26	11	9	13,1	.0114		
	16	2	110	27	12	9	15,1	.0116		
	18	2,5	125	30	14	11	16,85	.0118		
	20	2,5	140	32	16	12	18,85	.0120		

DIN 2174



» 285

» 285

Bei schlecht ausformenden Werkstoffen (z.B. GAL) empfehlen wir bei P ≥ 1 mm um 0,05 mm kleiner vorzubohren.
Weitere Informationen zu den empfohlenen Vorfertigungsdurchmessern siehe Seite 321.

We recommend a smaller preparatory diameter by 0.05 mm for difficult to form materials (such as aluminium cast alloys) for P ≥ 1 mm.
For further information regarding the recommended preparatory diameters, see page 321.

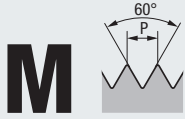

DIN 13

Mit extra langem Schaft
With extra long shank

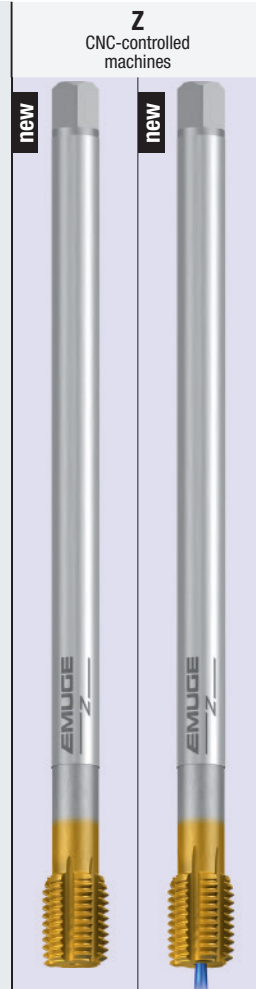
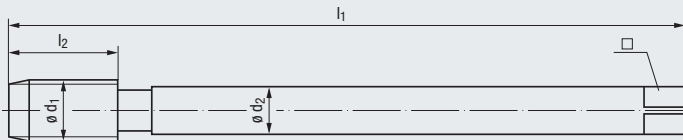

Technische Informationen Technical information	Toleranz · Tolerance Beschichtung · Coating Schneidstoff · Cutting material	6HX TIN-80 HSSE-PM	6HX TIN-80 HSSE-PM																																																	
		C / 2-3 E / O / P	C / 2-3 E / O																																																	
Gewindetiefe und Lochform Thread depth and hole type	max. 3 x d ₁ 	max. 3 x d ₁ 	max. 3 x d ₁ 																																																	
Einsatzgebiete – Material Application – material	P 1.1-5.1 M 1.1-3.1 ²⁾ K 2.1 N 2.1-2, 2.4-5 S 1.1-2.2 ²⁾ S 2.4 ²⁾	P 1.1-5.1 M 1.1-3.1 ²⁾ K 2.1 N 2.1-2, 2.4-5 S 1.1-2.2 ²⁾ S 2.4 ²⁾																																																		
Werkzeug-Ident · Tool ident		C555Z700 InnoForm 2-Z-SN-LS PM-TIN-80	C544Z700 InnoForm 2-Z-SN-1KZ LS-PM TIN-80																																																	
<table border="1"> <thead> <tr> <th>Ø d₁ mm</th> <th>P mm</th> <th>l₁</th> <th>l₂</th> <th>Ø d₂</th> <th>□</th> <th>Dimens.- Ident</th> </tr> </thead> <tbody> <tr> <td>M 10</td> <td>1,5</td> <td>200</td> <td>16</td> <td>7</td> <td>5,5</td> <td>9,35 .0100</td> </tr> <tr> <td>12</td> <td>1,75</td> <td>224</td> <td>18</td> <td>9</td> <td>7</td> <td>11,25 .0112</td> </tr> <tr> <td>14</td> <td>2</td> <td>224</td> <td>20</td> <td>11</td> <td>9</td> <td>13,1 .0114</td> </tr> <tr> <td>16</td> <td>2</td> <td>224</td> <td>22</td> <td>12</td> <td>9</td> <td>15,1 .0116</td> </tr> <tr> <td>18</td> <td>2,5</td> <td>250</td> <td>25</td> <td>14</td> <td>11</td> <td>16,85 .0118</td> </tr> <tr> <td>20</td> <td>2,5</td> <td>280</td> <td>25</td> <td>16</td> <td>12</td> <td>18,85 .0120</td> </tr> </tbody> </table>	Ø d ₁ mm	P mm	l ₁	l ₂	Ø d ₂	□	Dimens.- Ident	M 10	1,5	200	16	7	5,5	9,35 .0100	12	1,75	224	18	9	7	11,25 .0112	14	2	224	20	11	9	13,1 .0114	16	2	224	22	12	9	15,1 .0116	18	2,5	250	25	14	11	16,85 .0118	20	2,5	280	25	16	12	18,85 .0120		● ○ ● ○ ○	○ ○ ○ ○ ○
Ø d ₁ mm	P mm	l ₁	l ₂	Ø d ₂	□	Dimens.- Ident																																														
M 10	1,5	200	16	7	5,5	9,35 .0100																																														
12	1,75	224	18	9	7	11,25 .0112																																														
14	2	224	20	11	9	13,1 .0114																																														
16	2	224	22	12	9	15,1 .0116																																														
18	2,5	250	25	14	11	16,85 .0118																																														
20	2,5	280	25	16	12	18,85 .0120																																														
			286	286																																																

- Product Finder
- Vc
- M
- MF
- UNC
- UNF
- G
- SELF-LOCK
- Tech. Info



1) Gewindeformen in Durchgangslöchern nur mit externer Kühlschmierung möglich
Cold-forming in through holes is possible only with external cooling/lubrication

2) Mit Emulsion nur bedingt einsetzbar
Restricted application possibilities with emulsion

Bei schlecht ausformenden Werkstoffen (z.B. GAL) empfehlen wir bei P ≥ 1 mm um 0,05 mm kleiner vorzubohren.
Weitere Informationen zu den empfohlenen Vorfertigungsdurchmessern siehe Seite 321.

We recommend a smaller preparatory diameter by 0.05 mm for difficult to form materials (such as aluminium cast alloys) for P ≥ 1 mm.
For further information regarding the recommended preparatory diameters, see page 321.

- Product Finder
- Vc
- M**
- MF
- UNC
- UNF
- G
- SELF-LOCK
- Tech. Info

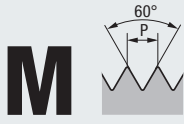

DIN 13

Für Gewindetiefen bis max. 3 x d₁
For thread depths up to max. 3 x d₁

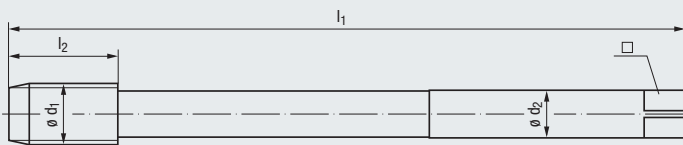

Technische Informationen
Technical information

» 305 - 324

Toleranz · Tolerance
Beschichtung · Coating
Schneidstoff · Cutting material



- | | |
|---------|---------|
| 6HX | 6HX |
| TIN-T26 | TIN-T26 |
| HSSE-PM | HSSE-PM |
| C / 2-3 | C / 2-3 |
| E / O | E / O |

Gewindetiefe und Lochform
Thread depth and hole type

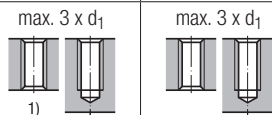

Einsatzgebiete – Material
Application – material

» 272

- | | |
|-----------|-----------|
| P 2.1-5.1 | P 2.1-5.1 |
| K 2.1 | K 2.1 |

Werkzeug-Ident · Tool ident

C599W700 C500W700

M	ø d ₁ mm	P mm	l ₁	l ₂	ø d ₂	□		Dimens.- Ident	InnoForm	InnoForm
									2-H-SN- IKZ LF3-PM TIN-T26	2-H-SN- IKZN LF3-PM TIN-T26
	24	3	215	30	18	14,5	22,6	.0124	○	○
	30	3,5	240	35	22	18	28,35	.0130	○	○
	33	3,5	255	35	25	20	31,35	.0133	○	○
	36	4	275	40	28	22	34,1	.0136	○	○
	42	4,5	295	45	32	24	39,85	.0142	○	○

1) Gewindeformen in Durchgangslöcher nur mit externer Kühlschmierung möglich
Cold-forming in through holes is possible only with external cooling/lubrication



Bei schlecht ausformenden Werkstoffen (z.B. GAL) empfehlen wir bei P ≥ 1 mm um 0,05 mm kleiner vorzubohren.
Weitere Informationen zu den empfohlenen Vorfertigungsdurchmessern siehe Seite 321.

We recommend a smaller preparatory diameter by 0.05 mm for difficult to form materials (such as aluminium cast alloys) for P ≥ 1 mm.
For further information regarding the recommended preparatory diameters, see page 321.

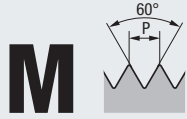

DIN 13

Für Gewindetiefen bis max. 4 x d₁
For thread depths up to max. 4 x d₁

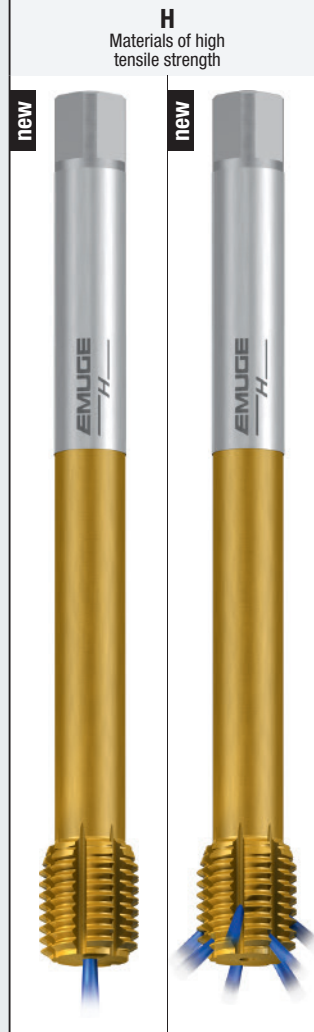
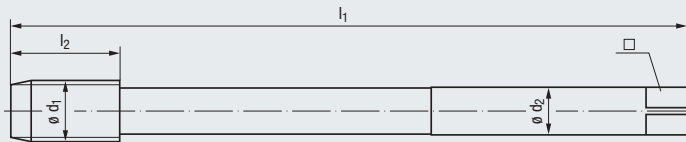

Technische Informationen
Technical information

» 305 - 324

Toleranz · Tolerance
Beschichtung · Coating
Schneidstoff · Cutting material



6HX	6HX
TIN-T26	TIN-T26
HSSE-PM	HSSE-PM
C / 2-3	C / 2-3
E / O	E / O

Gewindetiefe und Lochform
Thread depth and hole type

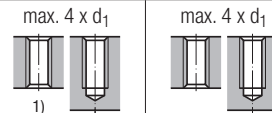

Einsatzgebiete – Material
Application – material

» 272

P 2.1-5.1	P 2.1-5.1
K 2.1	K 2.1

Werkzeug-Ident · Tool ident

C594W700 C595W700

M	Ø d ₁ mm	P mm	l ₁	l ₂	Ø d ₂	□	Dimens.- Ident	InnoForm	InnoForm
								2-H-SN- IKZ LF4-PM TIN-T26	2-H-SN- IKZN LF4-PM TIN-T26
	24	3	240	30	18	14,5	.0124	○	○
	30	3,5	270	35	22	18	.0130	○	○
	33	3,5	290	35	25	20	.0133	○	○
	36	4	310	40	28	22	.0136	○	○
	42	4,5	340	45	32	24	.0142	○	○

1) Gewindeformen in Durchgangslöchern nur mit externer Kühlschmierung möglich
Cold-forming in through holes is possible only with external cooling/lubrication



Bei schlecht ausformenden Werkstoffen (z.B. GAL) empfehlen wir bei P ≥ 1 mm um 0,05 mm kleiner vorzubohren.

Weitere Informationen zu den empfohlenen Vorfertigungsdurchmessern siehe Seite 321.

We recommend a smaller preparatory diameter by 0.05 mm for difficult to form materials (such as aluminium cast alloys) for P ≥ 1 mm.

For further information regarding the recommended preparatory diameters, see page 321.

Product Finder

- Vc
- M
- MF
- UNC
- UNF
- G
- SELF-LOCK
- Tech. Info



- Product Finder
- Vc
- M
- MF**
- UNC
- UNF
- G
- SELF-LOCK
- Tech. Info



DIN 13

DIN 2174

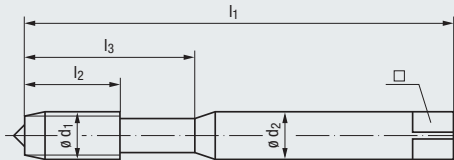

STEEL
Steel materials



Technische Informationen
Technical information

» 305 - 324

Toleranz · Tolerance
Beschichtung · Coating
Schneidstoff · Cutting material



6HX	6HX
TIN	TIN
HSSE	HSSE
C / 2-3	C / 2-3
E / O / P	E / O / P

Gewindetiefe und Lochform
Thread depth and hole type

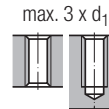

Einsatzgebiete – Material
Application – material

» 272

P 1.1-3.1	P 1.1-3.1
M 1.1-2.1 2)	M 1.1-2.1 2)
N 1.4-5, 2.1-2	N 1.4-5, 2.1-2

Werkzeug-Ident · Tool ident

B0911400 B0921400

M	ø d ₁ mm	P mm	l ₁	l ₂	l ₃	ø d ₂	□	Image	Dimens.- Ident	Drück	
										1-STEEL TIN	1-STEEL-SN TIN
	2,5	x 0,35	50	7	12	2,8	2,1	2,37	.0196		
	2,6	x 0,35	50	7	12	2,8	2,1	2,47	.0199		
	3	x 0,35	56	8	18	3,5	2,7	2,88	.0202		
	3,5	x 0,35	56	9	20	4	3	3,38	.0205		
	4	x 0,5	63	10	21	4,5	3,4	3,8	.0210	●	●
	5	x 0,5	70	11	25	6	4,9	4,8	.0218	●	●
	6	x 0,5	80	13	30	6	4,9	5,8	.0228	●	●
	6	x 0,75	80	13	30	6	4,9	5,7	.0229	●	●
	7	x 0,75	80	13	30	7	5,5	6,7	.0239		
	8	x 0,75	80	14	30	8	6,2	7,7	.0250	●	●
	8	x 1	90	17	35	8	6,2	7,6	.0251	●	●
	9	x 0,75	90	14	35	9	7	8,7	.0262		
	9	x 1	90	17	35	9	7	8,6	.0263		
	10	x 0,75	90	15	35	10	8	9,7	.0275		
	10	x 1	90	18	35	10	8	9,6	.0276	●	●
	10	x 1,25	100	18	39	10	8	9,45	.0277		

DIN 2174



» 296

» 296

1) Gewindeformen in Durchgangslöcher nur mit externer Kühlschmierung möglich
Cold-forming in through holes is possible only with external cooling/lubrication

2) Mit Emulsion nur bedingt einsetzbar
Restricted application possibilities with emulsion



Bei schlecht ausformenden Werkstoffen (z.B. GAL) empfehlen wir bei P ≥ 1 mm um 0,05 mm kleiner vorzubohren.
Weitere Informationen zu den empfohlenen Vorfertigungsdurchmessern siehe Seite 321.

We recommend a smaller preparatory diameter by 0.05 mm for difficult to form materials (such as aluminium cast alloys) for P ≥ 1 mm.
For further information regarding the recommended preparatory diameters, see page 321.

MF



DIN 13

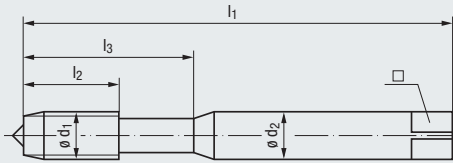

DIN 2174

Z
CNC-controlled machines

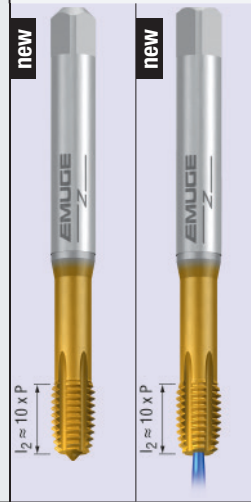

SPEED
High-speed cutting

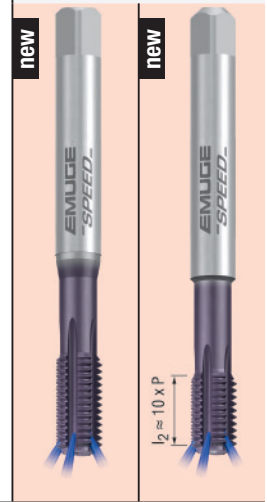

Technische Informationen
Technical information

» 305 - 324

Toleranz · Tolerance
Beschichtung · Coating
Schneidstoff · Cutting material



6HX	6HX
TIN-80	TIN-80
HSSE-PM	HSSE-PM
C / 2-3	C / 2-3
E / O / P	E / O

6HX	6HX
TICN	TICN
HSSE	VHM
E / 1,5-2	E / 1,5-2
E / O	E / O

Gewindetiefe und Lochform
Thread depth and hole type

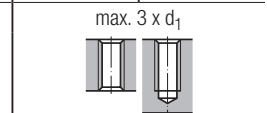
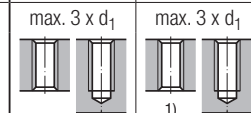

Einsatzgebiete – Material
Application – material

» 272

P 1.1-5.1	P 1.1-5.1
M 1.1-3.1²⁾	M 1.1-3.1²⁾
K 2.1	K 2.1
N 2.1-2, 2.4-5	N 2.1-2, 2.4-5
S 1.1-2.2²⁾	S 1.1-2.2²⁾
S 2.4²⁾	S 2.4²⁾

N 1.4-5	N 1.4-5
----------------	----------------

Werkzeug-Ident · Tool ident

B521Z700	B523Z700
InnoForm 1-Z-SN-PM TIN-80	InnoForm 1-Z-SN-IKZ PM-TIN-80

B5059500	B5050800
Drück 1-GAL SPEED/E-SN IKZN-TICN	VHM-Drück 1-GAL SPEED/E-SN IKZN-TICN

	ø d ₁ mm	P mm	l ₁	l ₂	l ₃	ø d ₂	□		Dimens.-Ident	Z		SPEED	
										B521Z700	B523Z700	B5059500	B5050800
M	2,5 x 0,35	50	7	12	2,8	2,1	2,37	.0196					
	2,6 x 0,35	50	7	12	2,8	2,1	2,47	.0199					
	3 x 0,35	56	8	18	3,5	2,7	2,88	.0202					
	3,5 x 0,35	56	9	20	4	3	3,38	.0205					
	4 x 0,5	63	10	21	4,5	3,4	3,8	.0210					
	5 x 0,5	70	11	25	6	4,9	4,8	.0218					
	6 x 0,5	80	13	30	6	4,9	5,8	.0228					
	6 x 0,75	80	13	30	6	4,9	5,7	.0229			○	○	
	7 x 0,75	80	13	30	7	5,5	6,7	.0239					
	8 x 0,75	80	14	30	8	6,2	7,7	.0250					
	8 x 1	90	17	35	8	6,2	7,6	.0251	●	●	○	○	
	9 x 0,75	90	14	35	9	7	8,7	.0262					
	9 x 1	90	17	35	9	7	8,6	.0263					
	10 x 0,75	90	15	35	10	8	9,7	.0275					
	10 x 1	90	18	35	10	8	9,6	.0276	●	●			
	10 x 1,25	100	18	39	10	8	9,45	.0277			○	○	

DIN 2174



» 297

» 297

» 298

» 298

¹⁾ Gewindeformen in Durchgangslöchern nur mit externer Kühlschmierung möglich
Cold-forming in through holes is possible only with external cooling/lubrication

²⁾ Mit Emulsion nur bedingt einsetzbar
Restricted application possibilities with emulsion



Bei schlecht ausformenden Werkstoffen (z.B. GAL) empfehlen wir bei P ≥ 1 mm um 0,05 mm kleiner vorzubohren.

Weitere Informationen zu den empfohlenen Vorfertigungsdurchmessern siehe Seite 321.

We recommend a smaller preparatory diameter by 0.05 mm for difficult to form materials (such as aluminium cast alloys) for P ≥ 1 mm.

For further information regarding the recommended preparatory diameters, see page 321.

- Product Finder
- V_c
- M
- MF**
- UNC
- UNF
- G
- SELF-LOCK
- Tech. Info

MF



DIN 13

DIN 2174

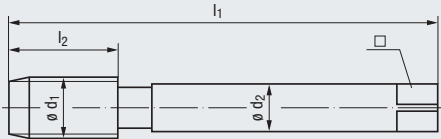

STEEL
Steel materials

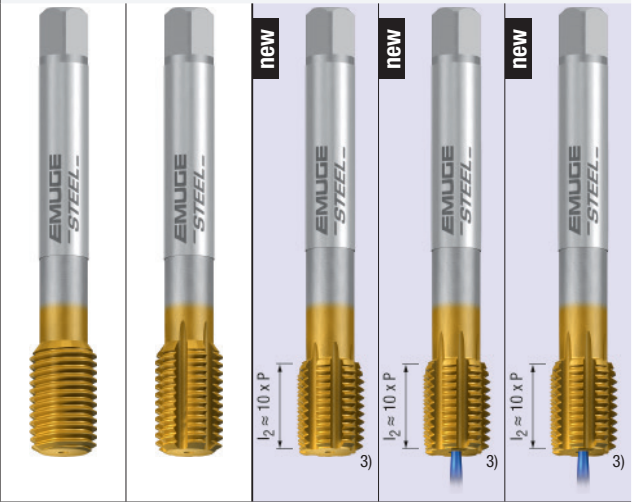

Toleranz · Tolerance
Beschichtung · Coating
Schneidstoff · Cutting material

Technische Informationen
Technical information

305 - 324



6HX	6HX	6HX	6HX	6HX
TIN	TIN	TIN-66	TIN-66	TIN-66
HSSE	HSSE	HSSE-PM	HSSE-PM	HSSE-PM
C / 2-3	C / 2-3	C / 2-3	C / 2-3	E / 1,5-2
E / O / P	E / O / P	E / O / P	E / O	E / O

Gewindetiefe und Lochform
Thread depth and hole type

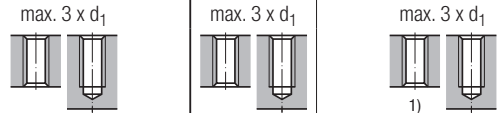

Einsatzgebiete – Material
Application – material

272

P 1.1-3.1	P 1.1-3.1	P 1.1-4.1	P 1.1-4.1	P 1.1-4.1
M 1.1-2.1 2)	M 1.1-2.1 2)	K 2.1	K 2.1	K 2.1
N 1.4-5, 2.1-2	N 1.4-5, 2.1-2			

Werkzeug-Ident · Tool ident

M	∅ d ₁ mm	P mm	l ₁	l ₂	∅ d ₂	□	Image	Dimens.- Ident	C0911400	C0921400	C5217F00	C5237F00	C5317F00
									Drück 2-STEEL TIN	Drück 2-STEEL-SN TIN	InnoForm 2-STEEL-M SN-PM TIN-66	InnoForm 2-STEEL-M SN-1KZ-PM TIN-66	InnoForm 2-STEEL-M/E SN-1KZ-PM TIN-66
11	x 1	90	18	8	6,2	10,6	.0288						
12	x 1	100	18	9	7	11,6	.0301	●	●				
12	x 1,25	100	22	9	7	11,45	.0302						
12	x 1,5	100	22	9	7	11,35	.0303	●	●	●	●	●	
14	x 1	100	18	11	9	13,6	.0329						
14	x 1,25	100	22	11	9	13,45	.0330						
14	x 1,5	100	22	11	9	13,35	.0331	●	●	●	●	●	
15	x 1	100	18	12	9	14,6	.0343						
15	x 1,5	100	22	12	9	14,35	.0345						
16	x 1	100	18	12	9	15,6	.0357	○	○				
16	x 1,5	100	22	12	9	15,35	.0359	●	●	●	●	●	
18	x 1	110	20	14	11	17,6	.0388						
18	x 1,5	110	25	14	11	17,35	.0390						
18	x 2	125	26	14	11	17,1	.0391						
20	x 1	125	20	16	12	19,6	.0420						
20	x 1,5	125	25	16	12	19,35	.0422	●	●				
20	x 2	140	27	16	12	19,1	.0423						

DIN 2174



294

294

1) Gewindeformen in Durchgangslöcher nur mit externer Kühlschmierung möglich
Cold-forming in through holes is possible only with external cooling/lubrication

2) Mit Emulsion nur bedingt einsetzbar
Restricted application possibilities with emulsion

3) Zum Patent angemeldet
Patent pending















Bei schlecht ausformenden Werkstoffen (z.B. GAL) empfehlen wir bei P ≥ 1 mm um 0,05 mm kleiner vorzubohren.

Weitere Informationen zu den empfohlenen Vorfertigungsdurchmessern siehe Seite 321.

We recommend a smaller preparatory diameter by 0.05 mm for difficult to form materials (such as aluminium cast alloys) for P ≥ 1 mm.

For further information regarding the recommended preparatory diameters, see page 321.

- Product Finder
- V_c
- M
- MF
- UNC
- UNF
- G
- SELF-LOCK
- Tech. Info

STEEL Steel materials			H Materials of high tensile strength		Z CNC-controlled machines		
							
6HX	6HX	6HX	6HX	6HX	6HX	6HX	
TICN-67	TICN-67	TICN-67	TIN-T26	TIN-T26	TIN-80	TIN-80	
HSSE-PM	HSSE-PM	HSSE-PM	HSSE-PM	HSSE-PM	HSSE-PM	HSSE-PM	
C / 2-3	C / 2-3	E / 1,5-2	C / 2-3	C / 2-3	C / 2-3	C / 2-3	
E / O / P	E / O	E / O	E / O	E	E / O / P	E / O	
max. 3 x d ₁	max. 3 x d ₁		max. 3 x d ₁	max. 3 x d ₁	max. 3 x d ₁	max. 3 x d ₁	
							
P 3.1-5.1	P 3.1-5.1	P 3.1-5.1	P 2.1-5.1	P 2.1-5.1	P 1.1-5.1	P 1.1-5.1	
K 2.1	K 2.1	K 2.1	K 2.1	K 2.1	M 1.1-3.1 ²⁾	M 1.1-3.1 ²⁾	
					K 2.1	K 2.1	
					N 2.1-2, 2.4-5	N 2.1-2, 2.4-5	
					S 1.1-2.2 ²⁾	S 1.1-2.2 ²⁾	
					S 2.4 ²⁾	S 2.4 ²⁾	
C5216F00	C5236F00	C5316F00	C521W700	C523W700	C521Z700	C523Z700	
InnoForm 2-STEEL-H SN-PM TICN-67	InnoForm 2-STEEL-H SN-IKZ-PM TICN-67	InnoForm 2-STEEL-H/E SN-IKZ-PM TICN-67	InnoForm 2-H-SN-PM TIN-T26	InnoForm 2-H-SN-IKZ PM-TIN-T26	InnoForm 2-Z-SN-PM TIN-80	InnoForm 2-Z-SN-IKZ PM-TIN-80	
							M 11 x 1
							12 x 1
							12 x 1,25
●	●	●	●	●	●	●	12 x 1,5
							14 x 1
							14 x 1,25
●	●	●	●	●	●	●	14 x 1,5
							15 x 1
							15 x 1,5
●	●	●	●	●	●	●	16 x 1
							16 x 1,5
							18 x 1
							18 x 1,5
							18 x 2
							20 x 1
							20 x 1,5
							20 x 2
					📄 295	📄 295	



Kühlschmierstoffe siehe Seite 238 - 239 Coolant-lubricants, see page 238 - 239

● = Lagerwerkzeug, siehe Preisliste · Stock tool, see price list
○ = Kurzfristig lieferbar, Preis auf Anfrage · Available on short notice, price upon inquiry

- Product Finder
- V_c
- M
- MF**
- UNC
- UNF
- G
- SELF-LOCK
- Tech. Info



DIN 13

DIN 2174

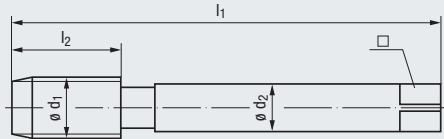

SPEED
High-speed cutting

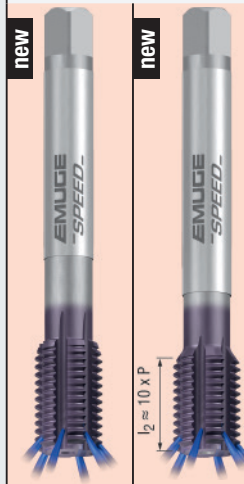

Technische Informationen
Technical information

→ 305 - 324

Toleranz · Tolerance
Beschichtung · Coating
Schneidstoff · Cutting material



6HX	6HX
TICN	TICN
HSSE	VHM
E / 1,5-2	E / 1,5-2
E / 0	E / 0

Gewindetiefe und Lochform
Thread depth and hole type

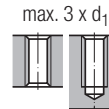

Einsatzgebiete – Material
Application – material

→ 272

N 1.4-5 **N 1.4-5**

Werkzeug-Ident · Tool ident

C5059500 **C505Q800**

M	∅ d ₁ mm	P mm	l ₁	l ₂	∅ d ₂	□	Image	Dimens.- Ident	Drück	VHM-Drück
									2-GAL SPEED/E-SN IKZN-TICN	2-GAL SPEED/E-SN IKZN-TICN
	11	x 1	90	18	8	6,2		.0288		
	12	x 1	100	18	9	7		.0301		
	12	x 1,25	100	22	9	7		.0302	○	○
	12	x 1,5	100	22	9	7		.0303	○	○
	14	x 1	100	18	11	9		.0329		
	14	x 1,25	100	22	11	9		.0330		
	14	x 1,5	100	22	11	9		.0331	○	○
	15	x 1	100	18	12	9		.0343		
	15	x 1,5	100	22	12	9		.0345		
	16	x 1	100	18	12	9		.0357		
	16	x 1,5	100	22	12	9		.0359	○	○
	18	x 1	110	20	14	11		.0388		
	18	x 1,5	110	25	14	11		.0390		
	18	x 2	125	26	14	11		.0391		
	20	x 1	125	20	16	12		.0420		
	20	x 1,5	125	25	16	12		.0422		
	20	x 2	140	27	16	12		.0423		

DIN 2174



→ 295

→ 295



Bei schlecht ausformenden Werkstoffen (z.B. GAL) empfehlen wir bei P ≥ 1 mm um 0,05 mm kleiner vorzubohren.

Weitere Informationen zu den empfohlenen Vorfertigungsdurchmessern siehe Seite 321.

We recommend a smaller preparatory diameter by 0.05 mm for difficult to form materials (such as aluminium cast alloys) for P ≥ 1 mm.

For further information regarding the recommended preparatory diameters, see page 321.

UNC

ASME B1.1



≈ DIN 2174

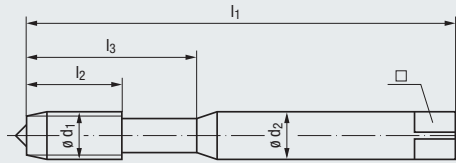

Technische Informationen
Technical information

» 305 - 324

Toleranz · Tolerance
Beschichtung · Coating
Schneidstoff · Cutting material



Gewindetiefe und Lochform
Thread depth and hole type

Einsatzgebiete – Material
Application – material

» 272

Werkzeug-Ident · Tool ident

ø d ₁ inch	P Gg/1" (tpi)	l ₁	l ₂	l ₃	ø d ₂	□	Dimens.- Ident	Drück 1-STEEL		Drück 1-Z-SN-PM	
								TIN	TIN	TIN-80	PM-TIN-80
Nr. 4	0.1120	40	56	11	18	3,5	2,7	2,55	.5003	●	●
Nr. 5	0.1250	40	56	11	18	3,5	2,7	2,9	.5004	●	●
Nr. 6	0.1380	32	56	12	20	4	3	3,15	.5005	●	●
Nr. 8	0.1640	32	63	13	21	4,5	3,4	3,8	.5006	●	●
Nr. 10	0.1900	24	70	15	25	6	4,9	4,35	.5007	●	●
Nr. 12	0.2160	24	80	16	30	6	4,9	5	.5008	●	●
1/4	0.2500	20	80	17	30	7	5,5	5,75	.5009	●	●
5/16	0.3125	18	90	20	35	8	6,2	7,3	.5010	●	●
3/8	0.3750	16	100	22	39	10	8	8,8	.5011	●	●

≈ DIN 2174



» 300

» 300

» 300

» 300

1) Gewindeformen in Durchgangslöchern nur mit externer Kühlschmierung möglich
Cold-forming in through holes is possible only with external cooling/lubrication

2) Mit Emulsion nur bedingt einsetzbar
Restricted application possibilities with emulsion



Bei schlecht ausformenden Werkstoffen (z.B. GAL) empfehlen wir bei P = 24 Gg./1" und größer um 0,05 mm kleiner vorzubohren.

Weitere Informationen zu den empfohlenen Vorfertigungsdurchmessern siehe Seite 321.

We recommend a smaller preparatory diameter by 0.05 mm for difficult to form materials (such as aluminium cast alloys) for P = 24 threads/1" and coarser threads.

For further information regarding the recommended preparatory diameters, see page 321.

Product Finder

Vc

M

MF

UNC

UNF

G

SELF-LOCK

Tech. Info



- Product Finder
- Vc
- M
- MF
- UNC**
- UNF
- G
- SELF-LOCK
- Tech. Info

UNC

ASME B1.1



≈ DIN 2174

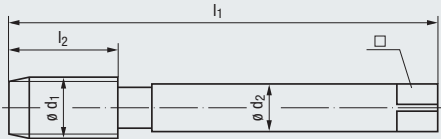

STEEL
Steel materials



Z
CNC-controlled machines

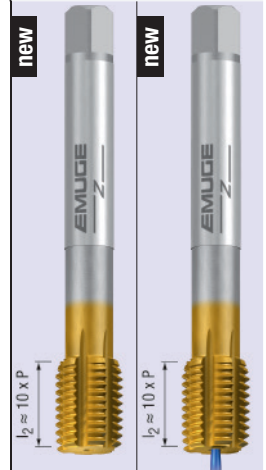

Technische Informationen
Technical information

305 - 324

Toleranz · Tolerance
Beschichtung · Coating
Schneidstoff · Cutting material



2BX	2BX	2BX	2BX
TIN	TIN	TIN-80	TIN-80
HSSE	HSSE	HSSE-PM	HSSE-PM
C / 2-3	C / 2-3	C / 2-3	C / 2-3
E / O / P	E / O / P	E / O / P	E / O

Gewindetiefe und Lochform
Thread depth and hole type



Einsatzgebiete – Material
Application – material

272

P 1.1-3.1	P 1.1-3.1	P 1.1-5.1	P 1.1-5.1
M 1.1-2.1 2)	M 1.1-2.1 2)	M 1.1-3.1 2)	M 1.1-3.1 2)
N 1.4-5, 2.1-2	N 1.4-5, 2.1-2	K 2.1	K 2.1
		N 2.1-2, 2.4-5	N 2.1-2, 2.4-5
		S 1.1-2.2 2)	S 1.1-2.2 2)
		S 2.4 2)	S 2.4 2)

Werkzeug-Ident · Tool ident

C0911400 C0921400 C521Z700 C523Z700

Ø d ₁ inch	P Gg/1" (tpi)	l ₁	l ₂	Ø d ₂	□	Dimens.- Ident	Drück 2-STEEL		Drück 2-STEEL-SN		InnoForm 2-Z-SN-PM		InnoForm 2-Z-SN-PM	
							TIN	TIN	TIN	IKZ	PM-TIN-80	PM-TIN-80		
7/16	0.4375	14	100	22	8	6,2	10,25	.5012	●	●	●	●	●	●
1/2	0.5000	13	110	25	9	7	11,8	.5013	●	●	●	●	●	●
9/16	0.5625	12	110	26	11	9	13,3	.5014	○	○	●	●	●	●
5/8	0.6250	11	110	27	12	9	14,8	.5015	●	●	●	●	●	●
3/4	0.7500	10	125	30	14	11	17,85	.5016	●	●	●	●	●	●
7/8	0.8750	9	140	32	18	14,5	20,9	.5017						
1"	1.0000	8	160	36	18	14,5	23,9	.5018						

≈ DIN 2174

299 299 299 299

1) Gewindeformen in Durchgangslöcher nur mit externer Kühlschmierung möglich
Cold-forming in through holes is possible only with external cooling/lubrication

2) Mit Emulsion nur bedingt einsetzbar
Restricted application possibilities with emulsion



Bei schlecht ausformenden Werkstoffen (z.B. GAL) empfehlen wir bei P = 24 Gg./1" und größer um 0,05 mm kleiner vorzubohren.
Weitere Informationen zu den empfohlenen Vorfertigungsdurchmessern siehe Seite 321.

We recommend a smaller preparatory diameter by 0.05 mm for difficult to form materials (such as aluminium cast alloys) for P = 24 threads/1" and coarser threads.
For further information regarding the recommended preparatory diameters, see page 321.

UNF



ASME B1.1

≈ DIN 2174

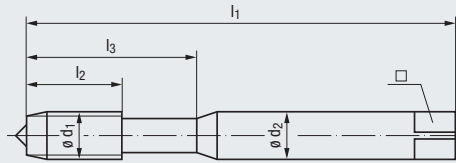

Technische Informationen
Technical information

» 305 - 324

Toleranz · Tolerance
Beschichtung · Coating
Schneidstoff · Cutting material



Gewindetiefe und Lochform
Thread depth and hole type

Einsatzgebiete – Material
Application – material

» 272

Werkzeug-Ident · Tool ident

ø d ₁ inch	P Gg/1" (tpi)	l ₁	l ₂	l ₃	ø d ₂	□	Image	Dimens.- Ident	STEEL Steel materials		Z CNC-controlled machines	
									Drück 1-STEEL TIN	Drück 1-STEEL-SN TIN	B521Z700 InnoForm 1-Z-SN-PM TIN-80	B523Z700 InnoForm 1-Z-SN-PM PM-TIN-80
Nr. 2 0.0860	64	45	7	12	2,8	2,1	2,02	.5035				
Nr. 3 0.0990	56	50	9	14	2,8	2,1	2,32	.5036				
Nr. 4 0.1120	48	56	11	18	3,5	2,7	2,62	.5037	●	●		
Nr. 5 0.1250	44	56	11	18	3,5	2,7	2,92	.5038				
Nr. 6 0.1380	40	56	12	20	4	3	3,22	.5039	●	●	●	
Nr. 8 0.1640	36	63	13	21	4,5	3,4	3,85	.5040	●	●	●	
Nr. 10 0.1900	32	70	15	25	6	4,9	4,45	.5041	●	●	●	●
Nr. 12 0.2160	28	80	16	30	6	4,9	5,1	.5042				
1/4 0.2500	28	80	17	30	7	5,5	5,95	.5043	●	●	●	●
5/16 0.3125	24	90	17	35	8	6,2	7,45	.5044	●	●	●	●
3/8 0.3750	24	90	18	35	10	8	9,05	.5045	●	●	●	●
≈ DIN 2174									» 302	» 302	» 302	» 302

1) Gewindeformen in Durchgangslöchern nur mit externer Kühlschmierung möglich
Cold-forming in through holes is possible only with external cooling/lubrication

2) Mit Emulsion nur bedingt einsetzbar
Restricted application possibilities with emulsion



Bei schlecht ausformenden Werkstoffen (z.B. GAL) empfehlen wir bei P = 24 Gg./1" und größer um 0,05 mm kleiner vorzubohren.

Weitere Informationen zu den empfohlenen Vorfertigungsdurchmessern siehe Seite 321.

We recommend a smaller preparatory diameter by 0.05 mm for difficult to form materials (such as aluminium cast alloys) for P = 24 threads/1" and coarser threads.

For further information regarding the recommended preparatory diameters, see page 321.

Product Finder

- Vc
- M
- MF
- UNC
- UNF**
- G
- SELF-LOCK
- Tech. Info



- Product Finder
- V_c
- M
- MF
- UNC
- UNF**
- G
- SELF-LOCK
- Tech. Info

UNF

ASME B1.1



≈ DIN 2174

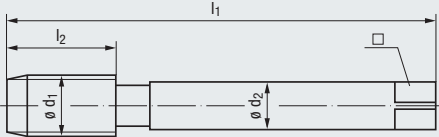

STEEL
Steel materials



Z
CNC-controlled machines

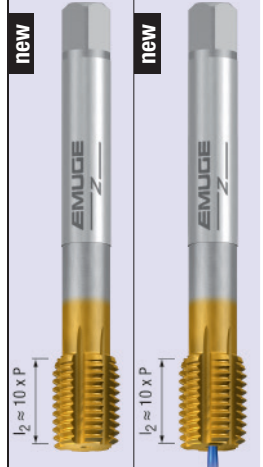

Technische Informationen
Technical information

305 - 324

Toleranz · Tolerance
Beschichtung · Coating
Schneidstoff · Cutting material



2BX	2BX	2BX	2BX
TIN	TIN	TIN-80	TIN-80
HSSE	HSSE	HSSE-PM	HSSE-PM
C / 2-3	C / 2-3	C / 2-3	C / 2-3
E / O / P	E / O / P	E / O / P	E / O

Gewindetiefe und Lochform
Thread depth and hole type



Einsatzgebiete – Material
Application – material

272

P 1.1-3.1	P 1.1-3.1	P 1.1-5.1	P 1.1-5.1
M 1.1-2.1 2)	M 1.1-2.1 2)	M 1.1-3.1 2)	M 1.1-3.1 2)
N 1.4-5, 2.1-2	N 1.4-5, 2.1-2	K 2.1	K 2.1
		N 2.1-2, 2.4-5	N 2.1-2, 2.4-5
		S 1.1-2.2 2)	S 1.1-2.2 2)
		S 2.4 2)	S 2.4 2)

Werkzeug-Ident · Tool ident

C0911400 C0921400 C521Z700 C523Z700

Ø d ₁ inch	P Gg/1" (tpi)	l ₁	l ₂	Ø d ₂	□	Dimens.- Ident	Drück 2-STEEL		InnoForm 2-Z-SN-PM	
							TIN	SN-TIN	TIN-80	PM-TIN-80
7/16	0.4375	20	100	22	8	6,2	10,55	.5046	●	●
1/2	0.5000	20	100	22	9	7	12,15	.5047	●	●
9/16	0.5625	18	100	22	11	9	13,65	.5048	○	○
5/8	0.6250	18	100	22	12	9	15,25	.5049	●	●
3/4	0.7500	16	110	25	14	11	18,35	.5050	●	●
7/8	0.8750	14	125	25	18	14,5	21,4	.5051		
1"	1.0000	12	140	28	18	14,5	24,45	.5052		

≈ DIN 2174



301

301

301

301

1) Gewindeformen in Durchgangslöcher nur mit externer Kühlschmierung möglich
Cold-forming in through holes is possible only with external cooling/lubrication

2) Mit Emulsion nur bedingt einsetzbar
Restricted application possibilities with emulsion



Bei schlecht ausformenden Werkstoffen (z.B. GAL) empfehlen wir bei P = 24 Gg./1" und größer um 0,05 mm kleiner vorzubohren.
Weitere Informationen zu den empfohlenen Vorfertigungsdurchmessern siehe Seite 321.

We recommend a smaller preparatory diameter by 0.05 mm for difficult to form materials (such as aluminium cast alloys) for P = 24 threads/1" and coarser threads.
For further information regarding the recommended preparatory diameters, see page 321.

G (BSP)

DIN EN ISO 228

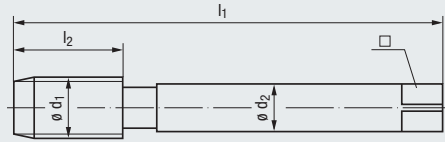
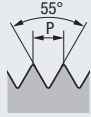

DIN 2189

STEEL
Steel materials



Z
CNC-controlled machines

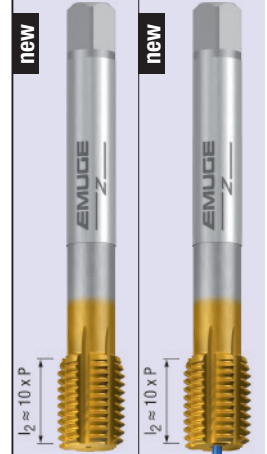

Technische Informationen
Technical information

» 305 - 324

Toleranz · Tolerance
Beschichtung · Coating
Schneidstoff · Cutting material



„X“	„X“	„X“	„X“
TIN	TIN	TIN-80	TIN-80
HSSE	HSSE	HSSE-PM	HSSE-PM
C / 2-3	C / 2-3	C / 2-3	C / 2-3
E / O / P	E / O / P	E / O / P	E / O

Gewindetiefe und Lochform
Thread depth and hole type



Einsatzgebiete – Material
Application – material

» 272

P 1.1-3.1	P 1.1-3.1	P 1.1-5.1	P 1.1-5.1
M 1.1-2.1 2)	M 1.1-2.1 2)	M 1.1-3.1 2)	M 1.1-3.1 2)
N 1.4-5, 2.1-2	N 1.4-5, 2.1-2	K 2.1	K 2.1
		N 2.1-2, 2.4-5	N 2.1-2, 2.4-5
		S 1.1-2.2 2)	S 1.1-2.2 2)
		S 2.4 2)	S 2.4 2)

Werkzeug-Ident · Tool ident

Nenngröße Nom. size	Ø d ₁ mm	P Gg/1" (tpi)	l ₁	l ₂	Ø d ₂	□	Image	Dimens.- Ident	C0911400		C0921400		C521Z700		C523Z700	
									Drück 2-STEEL TIN		Drück 2-STEEL-SN TIN		InnoForm 2-Z-SN-PM TIN-80		InnoForm 2-Z-SN-PM TIN-80	
G 1/16	7,72	28	90	17	6	4,9	7,25	.4034								
1/8	9,73	28	90	18	7	5,5	9,25	.4035	●	●			●	●		
1/4	13,16	19	100	22	11	9	12,55	.4036	●	●			●	●		
3/8	16,66	19	100	22	12	9	16,05	.4037	●	●			●	●		
1/2	20,96	14	125	25	16	12	20,1	.4038	●	●			●	●		
5/8	22,91	14	125	25	18	14,5	22,05	.4039								
3/4	26,44	14	140	28	20	16	25,6	.4040		○						
7/8	30,20	14	150	28	22	18	29,35	.4041								
1"	33,25	11	160	30	25	20	32,15	.4042			○					

1) Gewindeformen in Durchgangslöchern nur mit externer Kühlschmierung möglich
Cold-forming in through holes is possible only with external cooling/lubrication

2) Mit Emulsion nur bedingt einsetzbar
Restricted application possibilities with emulsion



Bei schlecht ausformenden Werkstoffen (z.B. GAL) empfehlen wir bei P = 24 Gg./1" und größer um 0,05 mm kleiner vorzubohren.

Weitere Informationen zu den empfohlenen Vorfertigungsdurchmessern siehe Seite 321.

We recommend a smaller preparatory diameter by 0.05 mm for difficult to form materials (such as aluminium cast alloys) for P = 24 threads/1" and coarser threads.

For further information regarding the recommended preparatory diameters, see page 321.

Product Finder

- Vc
- M
- MF
- UNC
- UNF
- G**
- SELF-LOCK
- Tech. Info



- Product Finder
- V_c
- M
- MF
- UNC
- UNF
- G
- SELF-LOCK**
- Tech. Info

LK-M

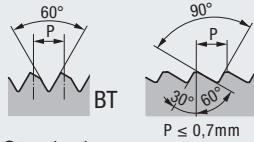

EMUGE-Norm · EMUGE Standard

DIN 2174

STEEL
Steel materials

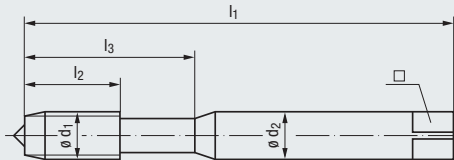

Technische Informationen
Technical information

» 305 - 324

Toleranz · Tolerance
Beschichtung · Coating
Schneidstoff · Cutting material



TIN	TIN
HSSE	HSSE
C / 2-3	C / 2-3
E / O / P	E / O / P

Gewindetiefe und Lochform
Thread depth and hole type

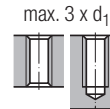

Einsatzgebiete – Material
Application – material

» 272

P 1.1-3.1	P 1.1-3.1
M 1.1-2.1 2)	M 1.1-2.1 2)
N 1.4-5, 2.1-2	N 1.4-5, 2.1-2

Werkzeug-Ident · Tool ident

B0911400 B0921400

Ø d ₁ mm	P mm	l ₁	l ₂	l ₃	Ø d ₂	□	Image	Dimens.- Ident	Drück	
									1-STEEL TIN	1-STEEL-SN TIN
LK-M 3	0,5	56	11	18	3,5	2,7	2,85	.1046	●	●
4	0,7	63	13	21	4,5	3,4	3,8	.1048	●	●
5	0,8	70	15	25	6	4,9	4,8	.1050	●	●
6	1	80	17	30	6	4,9	5,7	.1052	●	●
8	1,25	90	20	35	8	6,2	7,6	.1054	●	●
10	1,5	100	22	39	10	8	9,5	.1056	●	●

2) Mit Emulsion nur bedingt einsetzbar
Restricted application possibilities with emulsion

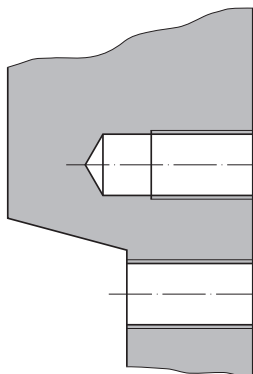

Ausführung BT
Type BT



BT = Keilfläche nach hinten geneigt
BT = Wedge ramp inclined backwards



Bei schlecht ausformenden Werkstoffen (z.B. GAL) empfehlen wir bei P ≥ 1 mm um 0,05 mm kleiner vorzubohren.
Weitere Informationen zu den empfohlenen Vorfertigungsdurchmessern siehe Seite 321.

We recommend a smaller preparatory diameter by 0.05 mm for difficult to form materials (such as aluminium cast alloys) for P ≥ 1 mm.
For further information regarding the recommended preparatory diameters, see page 321.

Technische Informationen

Technical Information

Seite · Page

2.1	EMUGE Gewindeformer-Bauformen Constructional designs of our EMUGE cold-forming taps	306
2.2	Gewindeformer-Sonderausführungen (Beispiele) Special cold-forming tap types (examples)	307
2.3	EMUGE Gewindeformer-Grundformen Basic types of our EMUGE cold-forming taps	308
2.4	EMUGE Geometriebezeichnungen Our EMUGE geometries	308 - 309
2.5	EMUGE Oberflächenbehandlungen und -Beschichtungen Our EMUGE surface treatments and coatings	310
2.6	Sonstige EMUGE-Kurzbezeichnungen Other EMUGE abbreviations	311
2.7	Anformkegelformen Lead taper forms	312
2.8	Kühl- und Schmierstoffe Cooling and lubrication agents	313
2.9	Toleranzfelder des Flankendurchmessers beim Metrischen Gewinde (schematische Darstellung) Tolerance zones of the pitch diameter on the Metric thread (graphic representation)	314
2.10	Toleranzfelder des Flankendurchmessers beim Unified-Gewinde (schematische Darstellung) Tolerance zones of the pitch diameter on the Unified thread (graphic representation)	315
2.11	Schematischer Drehmomentverlauf beim Gewindeformen Schematic of torque curve in the cold forming of threads	316
2.12	Umformverhalten und Drehmoment Cold forming and torque	317
2.13	Das Fertigungsverfahren Gewindeformen Cold forming as a production process	318
2.14	Der Unterschied zwischen spanend hergestelltem und geformtem Innengewinde The difference between a cut thread and a cold-formed thread	319
2.15	Gewindekernloch-Vorfertigungsdurchmesser für Gewindeformer Thread hole preparatory diameters for cold-forming taps	320 - 321
2.16	Lehrung und Toleranzen geformter Innengewinde Gauging and tolerances of cold-formed threads	322
2.17	Technischer Fragebogen: Gewindeformen Technical questionnaire: Cold forming of threads	323 - 324

Product
FinderV_c

M

MF

UNC

UNF

G

SELF-LOCK

Tech. Info





Die Technischen Informationen der jeweiligen Kapitel dieses Kataloges sind in vielen Landessprachen auch als separate Druckerzeugnisse verfügbar. Bitte wenden Sie sich an den für Sie zuständigen Vertriebspartner.

The technical information complementing the various chapters of this catalogue is available also as a separate printed booklet in many different languages. Please speak to your usual sales contact.

- Product Finder
- V_c
- M
- MF
- UNC
- UNF
- G
- SELF-LOCK
- Tech. Info

2.1 EMUGE Gewindeformer-Bauformen

Bauformen nach DIN (Beispiele)



	Bauform Constructional design	Baumaße Dimensions	EMUGE-Bezeichnung EMUGE designation
	Maschinen-Gewindeformer mit verstärktem Schaft Machine cold-forming taps with reinforced shank	DIN 2174	Drück 1 InnoForm 1
	Maschinen-Gewindeformer mit durchfallendem Schaft Machine cold-forming taps with reduced shank	DIN 2174	Drück 2 InnoForm 2

2.1 Constructional designs of our EMUGE cold-forming taps

Constructional designs acc. DIN (examples)

Bauformen nach EMUGE-Werknorm (Beispiele)

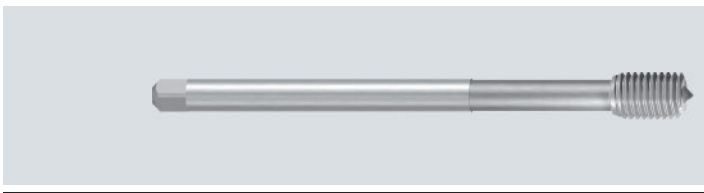
Constructional designs acc. EMUGE standard (examples)

	Bauform Constructional design	EMUGE-Bezeichnung EMUGE designation
	Maschinen-Gewindeformer mit langem Schaft Machine cold-forming taps with long shank	LF
	Maschinen-Gewindeformer mit extra langem Schaft Machine cold-forming taps with extra long shank	LS

Geometrischer Aufbau eines Gewindeformers

Geometric construction of a cold-forming tap

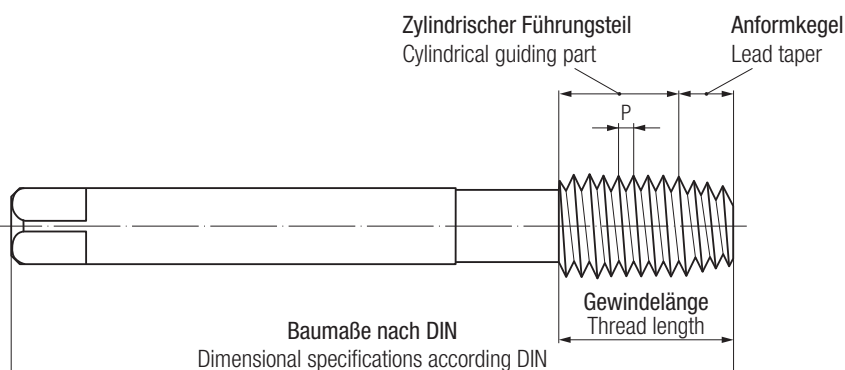
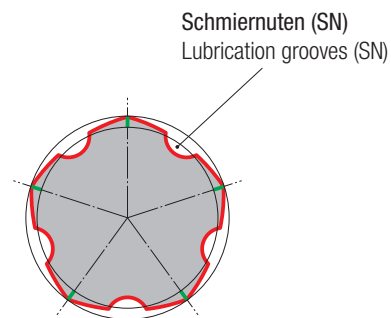
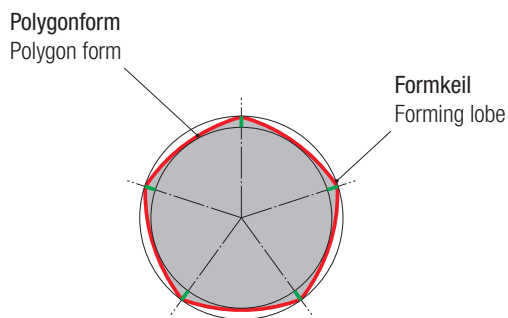

2.2 Gewindeformer-Sonderausführungen (Beispiele)

Sonderwerkzeuge nach Kundenwunsch

EMUGE fertigt Spezial-Gewindeformer nach Kundenzeichnungen und eigenen Konstruktionen.

InnoForm-Sonderwerkzeuge

Sollte für spezielle Anwendungsfälle im umfangreichen InnoForm-Gewindeformer-Programm keine geeignete Werkzeugvariante vorhanden sein, so werden kundenspezifisch, nach Angabe der Randbedingungen und der Werkstückzeichnung, InnoForm-Werkzeuge geliefert. Beispielsweise können spezielle Gewindeabmessungen und -toleranzen, Sondergewindeprofile, Sonderbauformen und besondere Verfahren zum kombinierten Gewindebohren und -formen bei der Konzeption beachtet werden.

Sondergewinde (Beispiele)

FG

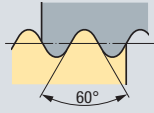

Fahrradgewinde
nach DIN 79012
Bicycle thread
acc. DIN 79012

Vg

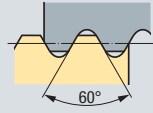

Ventilgewinde
nach DIN 7756
Valve thread
acc. DIN 7756

MFS

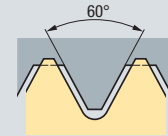

Metrisches ISO-Gewinde für Festsitz
nach DIN 8141-1
ISO Metric thread for tight fit
acc. DIN 8141-1

ST



Blechsraubengewinde
nach DIN EN ISO 1478
Sheet metal screw thread
acc. DIN EN ISO 1478

A/B

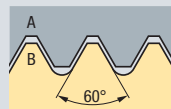

Stativ-Anschlussgewinde
nach DIN 4503
Tripod connection thread
acc. DIN 4503

2.2 Special cold-forming tap types (examples)

Special taps to customers' specifications

EMUGE produces special cold-forming taps to customers' drawings and proper specifications.

InnoForm special tools

If our comprehensive InnoForm programme of cold-forming taps does not include a suitable tool design for a specific application, we will be happy to furnish a custom-made, special InnoForm tool designed for the work conditions and according to the workpiece drawing of the individual customer. Such special designs can be made in special thread sizes and tolerances, with special thread profiles and dimensional specifications, or for special processes involving combined thread cutting and cold forming.

Special threads (examples)

Product
Finder

V_c

M

MF

UNC

UNF

G

SELF-LOCK

Tech. Info



- Product Finder
- V_c
- M
- MF
- UNC
- UNF
- G
- SELF-LOCK
- Tech. Info

2.3 EMUGE Gewindeformer-Grundformen

EMUGE stellte als weltweit erstes Unternehmen eine Reihe von Gewindeformern vor, die zur Bearbeitung von bestimmten Werkstoffen oder Werkstoffgruppen optimiert sind. War dies nur bei Schneidwerkzeugen möglich, so ist es EMUGE gelungen, Gewindeformer auf die Besonderheiten einzelner Werkstoffe und Werkstoffgruppen abzustimmen und dadurch die Leistung dieser Werkzeuge zum Teil deutlich zu erhöhen. Bis dahin waren Gewindeformer für den Einsatz in sämtlichen verformbaren Werkstoffen ausgelegt, wodurch in definierten Anwendungen Leistungspotential verschenkt wurde. EMUGE hat in mehrjähriger Entwicklungsarbeit die Mechanismen des Gewindeformens in bestimmten Werkstoffen untersucht und aus den erzielten Ergebnissen eine vollkommen neue Werkzeuggeneration geschaffen. Um dieses innovative Gewindeformer-Programm herauszuheben, wurde ein neuer Name gewählt: **InnoForm**

2.3 Basic types of our EMUGE cold-forming taps

EMUGE is the first threading tool manufacturer worldwide to introduce a programme of cold-forming taps specially designed for the machining of specific materials or material groups. While this was possible only for cutting tools, we have succeeded in designing cold-forming taps especially for the special properties of single materials and material groups, sometimes increasing performance in a dramatic way. Until then conventional cold-forming taps were made for the use in all ductile materials: potential performance features in defined applications were simply wasted in the process. EMUGE has made extensive investigations into the mechanisms of cold forming for years, and developed an entirely new tool generation from the results. In order to highlight the uniqueness of this highly innovative programme of cold-forming taps, we have thought of a new name: **InnoForm**

Drück



- Gewindeformer zur spanlosen Innengewinde-Herstellung
- Anformkegelform E (1,5-2 Gänge)
- Anformkegelform C (2-3 Gänge)
- Anformkegelform D (4-5 Gänge)
- Für Grundloch- und Durchgangslochgewinde

- Cold-forming tap for the chipless production of internal threads
- Lead taper form E (1.5-2 threads)
- Lead taper form C (2-3 threads)
- Lead taper form D (4-5 threads)
- For blind hole and through hole threads

InnoForm

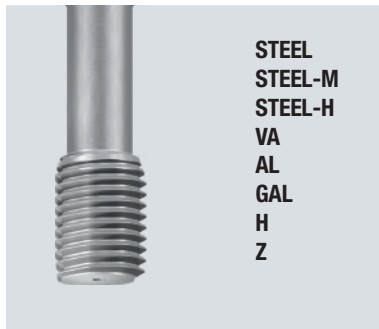

Bemerkung:
Abhängig vom zu bearbeitenden Material sind die wesentlichen Vorteile des Gewindeformens neben sehr guter Oberflächenqualität auch höhere statische und dynamische Festigkeit des Gewindes.
Die zu erzeugende Gewindelänge wird nicht durch abzuführende Späne begrenzt. Hervorragende Stabilität des Werkzeuges besonders bei kleinen Gewindeabmessungen. Sämtliche fließfähigen Werkstoffe können geformt werden. Auf ausreichende Schmierung muss geachtet werden. Schmiernuten werden grundsätzlich bei Durchgangslochgewinde und horizontaler Bearbeitung empfohlen (Ausnahme bei sehr kurzen Durchgangslochgewinden, wie z.B. bei Blechdurchzügen).

Note:
Depending on the workpiece material, the essential advantages of the cold-forming of threads are not only excellent surface quality but also higher static and dynamic strength of the thread. The length of the thread to be produced is not limited by chips which must be removed. The tools feature an excellent stability, especially with small thread sizes. All ductile materials can be cold-formed. Sufficient lubrication is essential. We generally recommend using oil grooves for through hole threads and horizontal machining. (Exception: very short through hole threads, e.g. sheet metal components).

Sometimes, it is necessary to adjust the recommended thread hole preparatory diameter to work conditions.

Evtl. muss der empfohlene Gewindekernloch-Vorfertigungsdurchmesser den Einsatzbedingungen angepasst werden.

2.4 EMUGE Geometriebezeichnungen

2.4 Our EMUGE geometries

**Drück
InnoForm**

Für Stahlwerkstoffe
Diese bewährte Geometrie ist für die allgemeine Anwendung in Stahl konzipiert. Sie ist in vielen Gewindesystemen und Abmessungen auf Lager. In Kombination mit Hartstoffschichten können Umfangsgeschwindigkeiten erhöht werden.

- **InnoForm-STEEL-M**
Für Stahlwerkstoffe mit mittlerer Festigkeit
- **InnoForm-STEEL-H**
Für Stahlwerkstoffe mit hoher Festigkeit

For steel materials
This highly successful geometry has been designed for general use in steel. It is available ex stock in numerous thread systems and sizes. Circumference speeds can be increased by combining it with a suitable hard surface coating.

- **InnoForm-STEEL-M**
For medium strength steels
- **InnoForm-STEEL-H**
For high strength steels

2.4 EMUGE Geometriebezeichnungen

2.4 Our EMUGE geometries

 InnoForm	<p>Für nichtrostende Stahlwerkstoffe und Stahlwerkstoffe</p> <p>Diese Werkstoffe verhalten sich stark adhäsiv, was zu Kaltpressschweißungen führen kann. Auch neigen diese Werkstoffe bei der Umformung stark zu verfestigen, wodurch die Formkeile stärker belastet werden. Um hier entgegenzuwirken, wurde eine Geometrie entwickelt, die den hohen Anforderungen hinsichtlich der Stabilität genügt.</p>	<p>For stainless steel materials and steel materials</p> <p>These materials show a high degree of adhesion which can lead to cold-welding effects. Also, they tend to strengthening during the forming process which puts more stress on the forming lobes. In order to compensate this, we have developed a geometry which meets the elevated requirements towards stability perfectly.</p>
 InnoForm	<p>Für Aluminium-Knetlegierungen</p> <p>Diese Werkstoffe zeigen unter üblichen Schmierungsverhältnissen, wie beispielsweise Emulsionsschmierung, eine stark adhäsive Neigung bei der Umformung des Gewindes. Um trotz dieses ungünstigen Werkstoffverhaltens ein positives Arbeitsergebnis zu erzielen, ist diese Geometrie mit einer Beschichtung ausgestattet, die sehr gute Reibungs- bzw. Gleiteigenschaften und damit eine optimale Prozesssicherheit bietet.</p>	<p>For aluminium wrought alloys</p> <p>Under the usual lubrication conditions, e.g. emulsion lubrication, these materials show a strong inclination to adhesion in the cold forming of threads. In order to obtain satisfactory work results in spite of these unfavourable material properties, this geometry was provided with a coating that offers excellent friction characteristics and, as a result, a perfect degree of process safety.</p>
 Drück InnoForm	<p>Für Aluminium-Gusslegierungen</p> <p>Bei der Anwendung von Gewindeformern in Aluminiumguss-Werkstoffen, stellt sich eine starke abrasive Belastung der Formkeile ein. Weiterhin sind die Umformeigenschaften dieser eher spröden Materialien als relativ schlecht einzuordnen. Um bei diesen schwierigen Bedingungen sehr gute Ergebnisse hinsichtlich des Gewindefertigungsprozesses und des Verschleißes zu erhalten, wurde bei diesem Typ die Geometrie angepasst und der Former zusätzlich mit einer Hartstoffschicht versehen.</p>	<p>For aluminium cast alloys</p> <p>Cast aluminium materials exert a very strong abrasive stress on the forming lobes of a cold-forming tap during work. In addition, the ductile properties of these rather brittle materials must be regarded as relatively poor. In order to achieve easier thread production and better wear resistance even under these bad conditions, we have given this tool type a specially adjusted geometry and an additional hard surface coating.</p>
 InnoForm	<p>Für hochfeste Werkstoffe</p> <p>Diese Geometrie wurde ausgelegt, um Werkstoffe umzuformen, deren Umform-eigenschaften eingeschränkt sind. Die spezielle Werkzeuggeometrie mit einer entsprechenden Hartstoffschicht liefert eine gute Qualität der gefertigten Gewinde bei sehr guter Verschleißbeständigkeit.</p>	<p>For materials of high tensile strength</p> <p>This geometry was designed for the cold forming of materials with restricted ductile properties. The special tool geometry, combined with an appropriate hard surface coating, provides excellent quality of the finished threads and very good wear resistance.</p>
 InnoForm	<p>Für CNC-gesteuerte Maschinen</p> <p>Diese Geometrie zielt darauf ab, speziell für CNC-gesteuerte Maschinen die entstehenden Reibungskräfte und Wärmebelastungen an den Formkeilen zu verringern. Bei synchron gesteuertem Vorschub kommt die Leistungsfähigkeit besonders in Verbindung mit Spannzangen-Aufnahmen der Typenreihe Softsynchro® zum Tragen.</p>	<p>For CNC-controlled machines</p> <p>This geometry is aimed at reducing the unavoidable friction forces and the heat stress on the forming lobes especially for use on CNC-controlled machines. With a synchronous feed control, the performance potential of these tools can be used to the full, especially in combination with the collet holders of our Softsynchro® series.</p>
 Drück	<p>Zum Hochgeschwindigkeitsbohren</p> <p>CNC-Maschinen, besonders in Verbindung mit Spannzangen-Aufnahmen der Typenreihe Speedsynchro® Modular, geben die Voraussetzung, hohe Drehzahlen zu fahren. Die spezielle Geometrie, in Verbindung mit einer Hartstoffschicht, bietet hier die Möglichkeit, auch hohe Schnittgeschwindigkeiten zu realisieren.</p>	<p>For high-speed tapping</p> <p>CNC machines, especially in combination with the collet holders of our Speedsynchro® Modular series, make very high speeds possible. The special geometry of these tools, combined with a hard surface coating, offers you the chance to do your machining at the highest speeds your machine can manage.</p>



- Product Finder
- V_c
- M
- MF
- UNC
- UNF
- G
- SELF-LOCK

2.5 EMUGE Oberflächenbehandlungen und -Beschichtungen

2.5 Our EMUGE surface treatments and coatings

Tech. Info

NT



Nitrieren

Durch thermochemische Behandlung wird die Oberfläche im Bereich von ca. 0,03 bis 0,05 mm Eindringtiefe mit Stickstoff angereichert. Da die Oberfläche sehr hart (1000-1250 HV) wird, eignen sich nitrierte Werkzeuge für abrasive Werkstoffe wie Grauguss, Sphäroguss, Aluminiumguss sowie auch Duroplaste. Der Standwert wird entscheidend erhöht.

Nitriding

In a thermo-chemical treatment, the surface is enriched with nitrogen to a depth of approx. 0.03 to 0.05 mm. Since the surface becomes very hard (1000-1250 HV), nitrided tools are a very good choice for abrasive materials like cast iron, spheroidal cast iron, cast aluminium and duroplastics. Tool life is increased in a decisive manner.

TIN

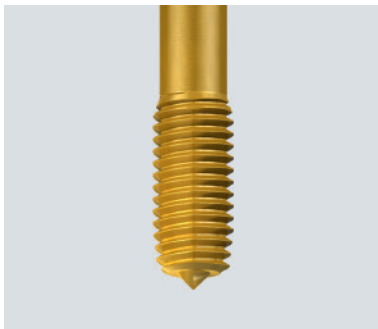

Titannitrid (goldgelb)

Im PVD-Verfahren (500 °C) werden Schichtdicken von 3-7 µm erreicht. Die **glatten** Schichten zeichnen sich durch hohe Schichthaftung und TIN-typische Eigenschaften gegen Aufschweißungen aus.

TIN-Schichtsysteme mit Zusatzkennnummer (z.B. TIN-66, TIN-80) sind bezüglich Substrat, Werkzeuggeometrie und Anwendung optimiert.

Titanium nitride (gold-yellow)

In a PVD process (500 °C) a coating thickness of 3-7 µm can be realised. The **smooth** coatings feature a high adhesion strength and TIN-typical properties against cold welding.

TIN coating systems with additional code number (e.g. TIN-66, TIN-80) are optimised with regard to substrate, tool geometry and application.

CR

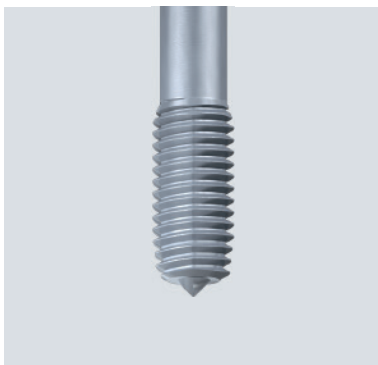

Hartverchromen

Die Hartchromschicht erreicht eine Härte von 1200 bis 1400 HV. Sie zeigt hervorragende Gleiteigenschaften. Die Schichtdicke beträgt 2-4 µm. Vor allem in Buntmetallen und Thermoplasten erreicht man Verbesserungen der Standwerte. Nicht zu empfehlen ist der Einsatz in Stahlwerkstoffen. Hier werden beim Umformvorgang Temperaturen von 250 °C sehr oft überschritten. Eine Haftung der Hartchromschicht ist dann nicht mehr gewährleistet.

Hard chrome plating

The hard chrome surface reaches a hardness of 1200 to 1400 HV, and shows excellent anti-friction properties. The thickness of the coating is 2-4 µm. Tool life can be considerably increased, especially in non-ferrous metals and thermoplastics. However, we do not recommend the use of this coating in steel materials. Here, temperatures of 250 °C are often exceeded in a cold-forming process, and that might endanger the adhesion of the hard chrome plating.

TICN

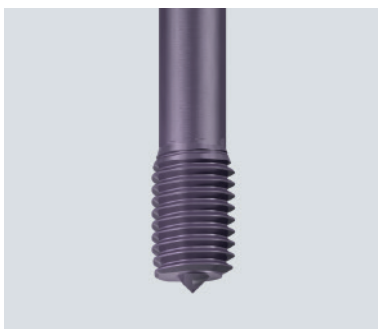

Titan-Carbonitrid (blau-grau)

Im PVD-Verfahren (500 °C) werden Schichtdicken von 2-4 µm erreicht. Die Härte beträgt hier ca. 3000 HV. Die TICN-Schicht bleibt bis ca. 400 °C beständig.

TICN-Schichtsysteme mit Zusatzkennnummer (z.B. TICN-67) sind bezüglich Substrat, Werkzeuggeometrie und Anwendung optimiert.

Titanium carbonitride (blue-grey)

In a PVD process (500 °C) a coating thickness of 2-4 µm can be realised. The hardness is approx. 3000 HV. The TICN coating will resist up to approx. 400 °C.

TICN coating systems with additional code number (e.g. TICN-67) are optimised with regard to substrate and application.

GLT-8

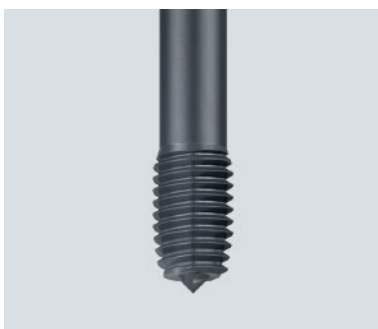

Diamantähnliche, amorphe Kohlenstoffschicht (schwarz-grau)

Im PVD-Verfahren werden Schichtdicken von ca. 1-2 µm erreicht. Die Härte beträgt ca. 2500 HV. Diese Monolayerschicht eignet sich hervorragend zur Bearbeitung von Buntmetallen und Aluminium mit niedrigem Si-Gehalt (< 7% Si). Durch den geringen Reibwert wird Werkstoffadhäsion stark vermindert. Die Schicht bleibt bis ca. 350 °C beständig.

Diamond-like, amorphous carbon coating (black-grey)

In a PVD process a coating thickness of 1-2 µm can be realised. The hardness is approx. 2500 HV. This mono-layer coating is an excellent choice for the machining of non-ferrous metals and aluminium with a low silicon content (< 7% Si). Thanks to the low friction, material adhesion is drastically reduced. This coating will remain resistant up to approx. 350 °C.

2.6 Sonstige EMUGE-Kurzbezeichnungen

2.6 Other EMUGE abbreviations

Product
FinderV_c

M

MF

UNC

UNF

G

SELF-LOCK

Tech. Info

IKZ

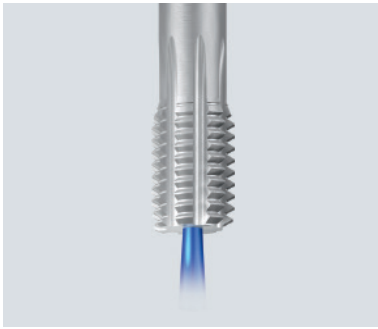
**Innere Kühlschmierstoff-Zufuhr, axial
(DIN-Bezeichnung: KA)**

Axialer Austritt des Kühlschmierstoffes bietet optimale Kühlschmierung im Anformkegelbereich.

**Internal coolant supply, axial
(DIN designation: KA)**

The axial exit of coolant-lubricant provides optimum cooling and lubrication in the lead taper area.

IKZN

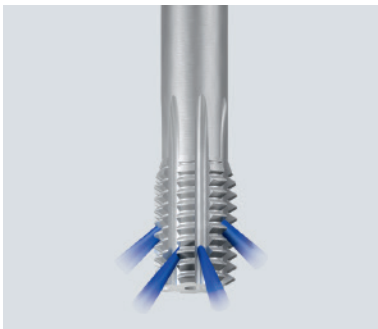
**Innere Kühlschmierstoff-Zufuhr, axial
mit Austritt in den Schmiernuten
(DIN-Bezeichnung: KR)**

Radialer Austritt bringt auch beim Durchgangsloch den Kühlschmierstoff prozesssicher in den Anformkegelbereich.

**Internal coolant supply, axial,
with coolant exiting in the flutes
(DIN designation: KR)**

Radial exit of coolant-lubricant is the safest solution for providing coolant supply in the lead taper area even in through holes.

BL

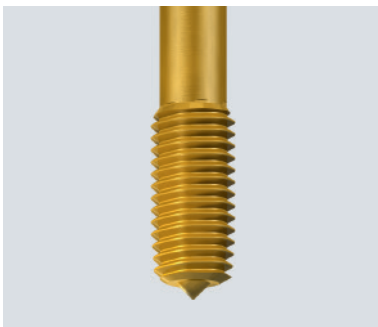
**Für Blechdurchzüge**

Die Ausführung BL basiert je nach Werkstoffwahl auf dem jeweiligen InnoForm-Grundwerkzeug. Allerdings wird der Anformkegel verlängert, um eine bessere Zentrierung des Werkzeuges zu erreichen. Zusätzlich garantiert die erhöhte Gewindelänge ein sicheres Reversieren, auch bei ungenaueren Umschaltzyklen.

For sheet metal components

The various BL designs are based each on an appropriate basic InnoForm tool, depending on the choice of material. Their special features include an extra long lead taper for a safer centering of the tool, and increased thread length for safe reversal, even with less exact reversing cycles.

VHM

**Vollhartmetall**

Werkzeuge mit einem Gewindenenddurchmesser < 12,0 mm werden aus Vollhartmetall (Gewinde- und Schaftteil) gefertigt.

Solid carbide

Tools with a thread diameter < 12.0 mm are made of solid carbide (thread part and shank).



2.7 Anformkegelformen

Anformkegelformen und Anformkegellängen für Gewindeformer nach DIN 2175.

2.7 Lead taper forms

Lead taper forms and lead taper lengths for cold-forming taps acc. DIN 2175.

Form C

Anformkegellänge 2-3 Gänge

Lead taper length 2-3 threads



Form D

Anformkegellänge 3-5,5 Gänge

Lead taper length 3-5.5 threads

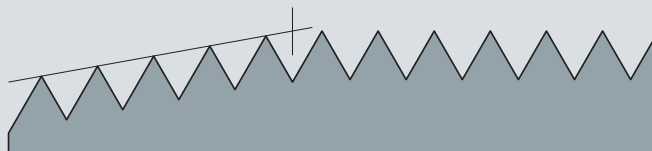

Form E

Anformkegellänge 1,5-2 Gänge

Lead taper length 1.5-2 threads



Form F

Anformkegellänge 1-1,5 Gänge

Lead taper length 1-1.5 threads



2.8 Kühl- und Schmierstoffe

Dem Schmiermittel wird im Allgemeinen zu wenig Bedeutung geschenkt. Um vom Werkzeug die volle Leistung zu erhalten, muss der richtige Kühlschmierstoff verwendet werden.

Grundsätzlich unterscheiden wir folgende Arten der Kühlung und Schmierung:

E

Emulsion

(EMUGE-Gewindeschneidöl Nr. 3+ EMULSION)

Die gebräuchlichste Kühlschmierung auf Bearbeitungszentren.

2.8 Cooling and lubrication agents

Lubricants are often, if not generally, given too little consideration. If you want to get the best performance out of your tool you have to take care to use the best coolant-lubricant available.

In general, we distinguish the following types of cooling and lubrication:

Emulsion

(EMUGE thread cutting oil no. 3+ EMULSION)

The most common type of coolant-lubricant on machining centres.

M

Minimalmengenschmierung (MQL)

Durch die Möglichkeit Luft-Ölgemisch bei modernen Bearbeitungszentren durch die Spindel zu fördern, gewinnt diese Art der Kühlschmierung mehr und mehr an Bedeutung.

Minimum-quantity lubrication (MQL)

Due to the more and more common option of supplying aerosol through the spindle on modern machining centres, this type of cooling and lubrication is gaining more and more popularity.

O

Gewindeschneidöl

(EMUGE-Gewindeschneidöle Nr. 1+ STEEL, Nr. 2+ CAST IRON, Nr. 4+ NON FERROUS, Nr. 5+ HIGH ALLOY)

Abgestimmt auf die zu bearbeitenden Werkstoffe werden hervorragende Gewindeoberflächen und Standwerte erreicht.

Thread cutting oil

(EMUGE thread cutting oils no.1+ STEEL, no. 2+ CAST IRON, no. 4+ NON FERROUS, no. 5+ HIGH ALLOY)

With these oils which are perfectly adjusted to specific materials, excellent thread surfaces and tool life can be achieved.



P

Gewindeschneidpaste

(EMUGE-Gewindeschneidpaste Nr. 6+ PASTE)

Zum Gewindeformen hervorragend geeignet. Besonders vorteilhaft bei waagrechtter Bearbeitung, großen Abmessungen und Durchgangslochgewinden. Kann nur für Pinselschmierung verwendet werden.

Thread cutting paste

(EMUGE thread cutting paste no. 6+ PASTE)

Perfectly suitable for the cold forming of threads. Especially useful in horizontal machining, with large thread sizes and through hole threads. To be used only for brush lubrication.

- Product Finder
- V_c
- M
- MF
- UNC
- UNF
- G
- SELF-LOCK
- Tech. Info

2.9 Toleranzfelder des Flankendurchmessers beim Metrischen Gewinde (schematische Darstellung)

2.9 Tolerance zones of the pitch diameter on the Metric thread (graphic representation)

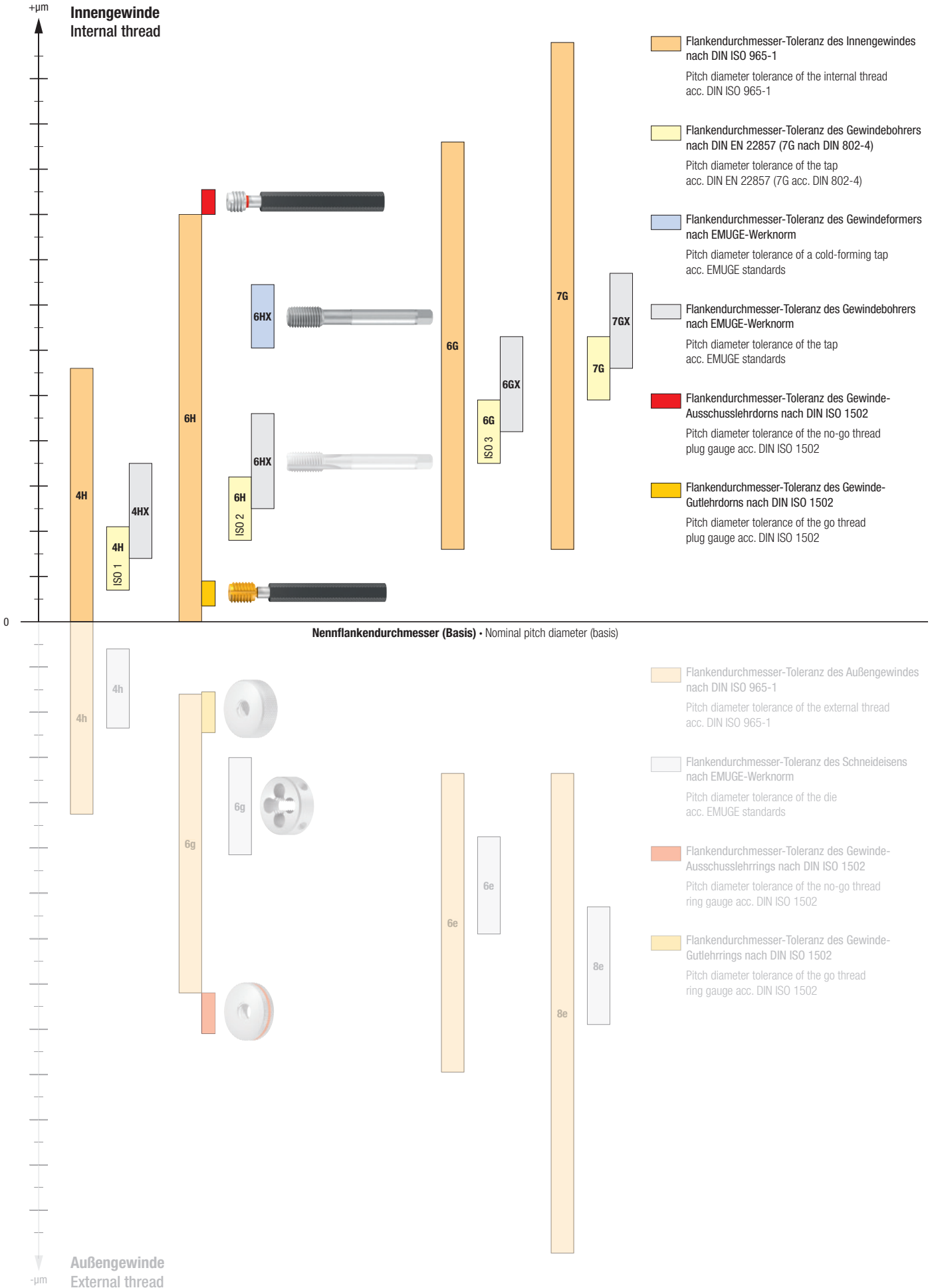

2.10 Toleranzfelder des Flankendurchmessers beim Unified-Gewinde (schematische Darstellung)

2.10 Tolerance zones of the pitch diameter on the Unified thread (graphic representation)

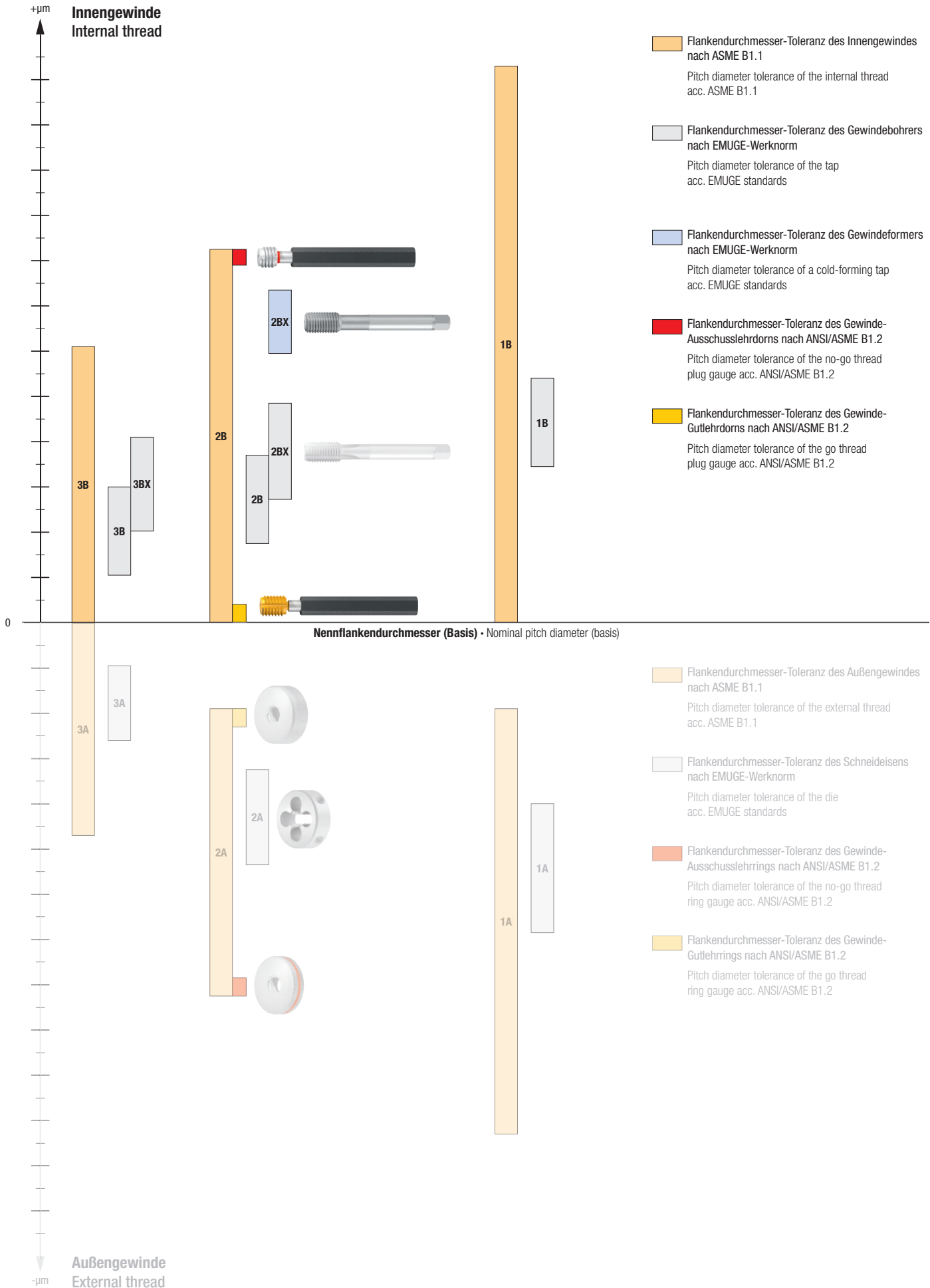

Product Finder

V_c

M

MF

UNC

UNF

G

SELF-LOCK

Tech. Info



- Product Finder
- V_c
- M
- MF
- UNC
- UNF
- G
- SELF-LOCK
- Tech. Info

2.11 Schematischer Drehmomentverlauf beim Gewindeformen

2.11 Schematic of torque curve in the cold forming of threads

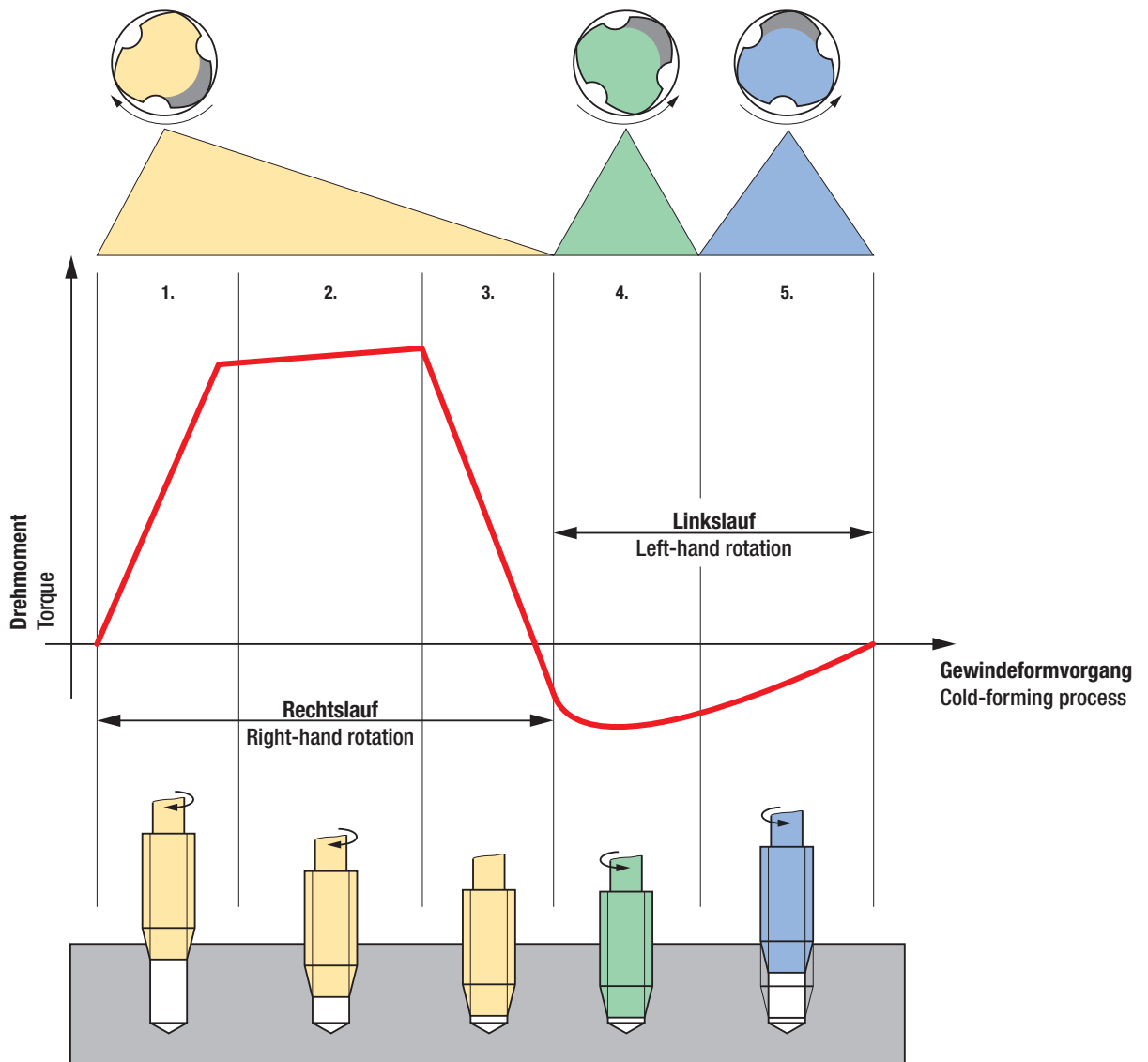

1. Anformen des Gewindeformers bis zum Eingriff aller Anformzähne

2. Formmomente des vollständig im Eingriff befindlichen Anformkegels

3. Abbremsen der Maschinenspindel bis zum Stillstand

1. Beginning of forming process until all lead taper teeth are in contact.

2. Forming work of the lead taper which is now in full contact.

3. Braking the machine spindle to a stop

4. Beginnender Rücklauf der Spindel mit Gleitreibung

4. Beginning reversal of the spindle with sliding friction

5. Gleitreibung zwischen Gewindeformer und Werkstück

5. Sliding friction between cold-forming tap and workpiece

2.12 Umformverhalten und Drehmoment

2.12 Cold forming and torque

Kennwerte des Werkstück-Werkstoffes

Nicht alle Werkstoffe sind zum Formen geeignet. Sie müssen ein Mindestmaß an Fließfähigkeit aufweisen und dürfen eine bestimmte Werkstofffestigkeit nicht überschreiten. Geeignete Werkstoffe liegen in der Zugfestigkeit unter 1400 N/mm², bei einer Bruchdehnung von mindestens 5%. Außerdem führen unterschiedliche Materialien und deren Legierungen zu sehr spezifischen Fließeigenschaften und Verfestigungsverhalten. Es ist offensichtlich, dass z.B. Knetaluminium, hochfester Stahl oder VA-Material völlig unterschiedlich reagieren.

Drehmoment

Das Drehmoment beim Gewindeformen ist im Wesentlichen abhängig vom zu bearbeitenden Material, der Gewindeabmessung, von Schmierung und Gewindekernloch-Vorfertigungsdurchmesser, sowie der Geometrie und Beschichtung des Werkzeuges. Den Einfluss des Vorfertigungsdurchmessers auf das Drehmoment zeigt das folgende Diagramm.

Technical data of the workpiece material

Not all materials are suitable for cold forming. For that, they must show a minimum value of ductility and must not exceed a certain maximum strength. Suitable materials usually have a tensile strength of less than 1400 N/mm² and a minimum fracture strain of 5%. In addition, different materials and their alloys lead to very specific flow properties and strengthening characteristics. Obviously, wrought aluminium, high-strength steel or stainless materials will react in very different ways.

Torque

Torque, in the cold forming of threads, depends mostly on the workpiece material, the thread size, lubrication and thread hole preparatory diameter, as well as on the geometry and the coating of the tool. The influence of the preparatory diameter on torque is shown in the following diagram.

InnoForm, M10-6HX
Werkstoff C45
n = 350 min⁻¹
InnoForm, M10-6HX
Material C45
n = 350 rpm

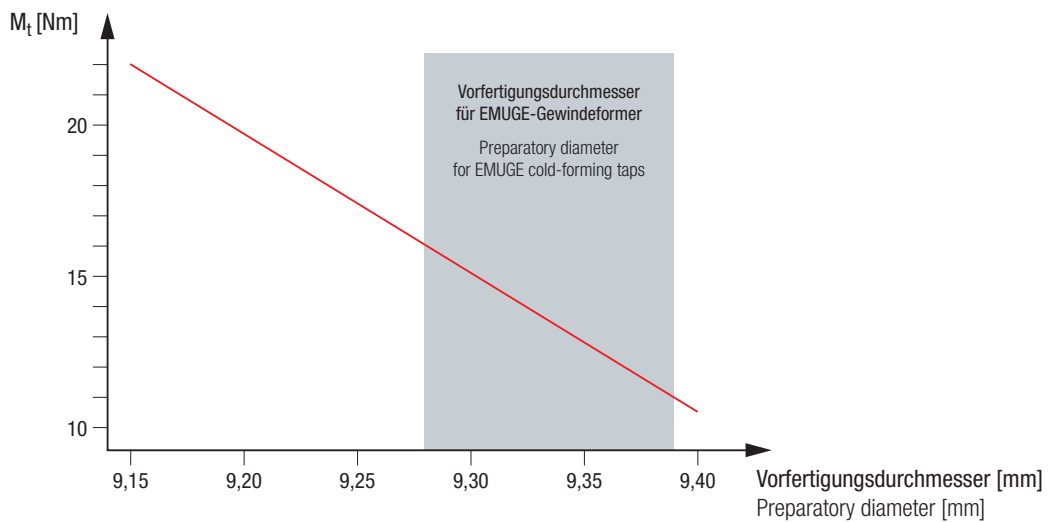

Die folgende Grafik zeigt schematisch den Drehmoment-Unterschied zwischen Gewindebohren und Gewindeformen.

The following diagram demonstrates the difference in torque between thread cutting and cold forming.

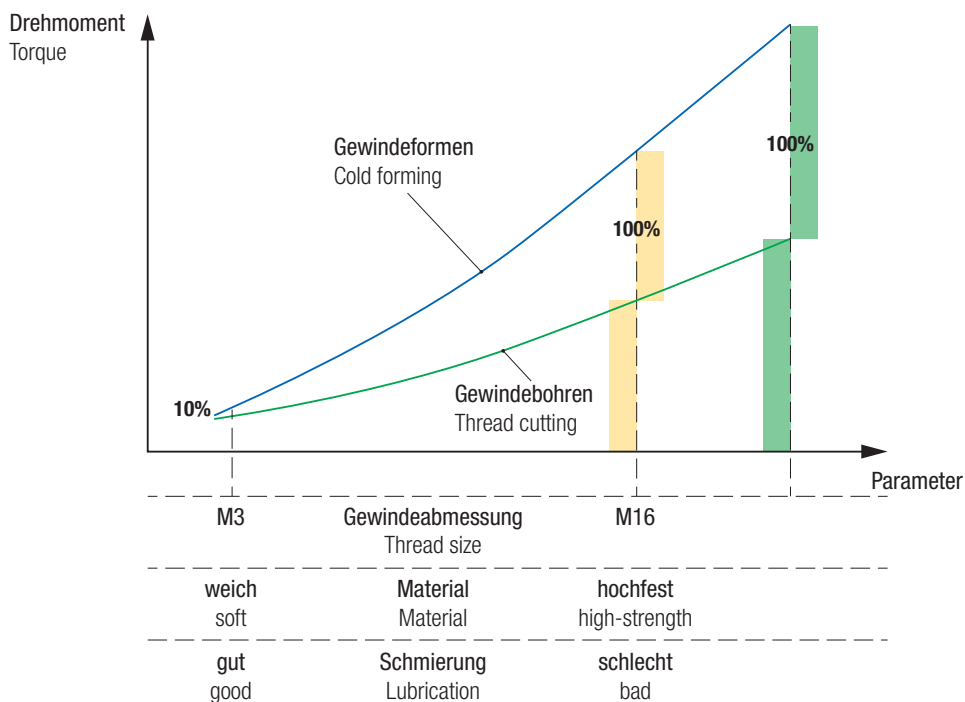

- Product Finder
- V_c
- M
- MF
- UNC
- UNF
- G
- SELF-LOCK
- Tech. Info**



- Product Finder
- V_c
- M
- MF
- UNC
- UNF
- G
- SELF-LOCK
- Tech. Info

2.13 Das Fertigungsverfahren Gewindeformen

Das Gewindeformen ist nach DIN 8583-5 den druckumformenden Verfahren zugeordnet. Das Innengewinde wird durch Eindrücken der schraubenförmig angeordneten Gewindezähne in die vorgefertigte Bohrung druckumformend erzeugt. Das Gewindeformwerkzeug besitzt einen Anformkegel sowie einen zylindrischen Führungsteil. Durch beide Bereiche verläuft schraubenförmig der Gewindegang. Im Querschnitt ist senkrecht zur Werkzeugachse ein polygonförmiges Profil zu erkennen. Dadurch ergeben sich Formkeile mit dem wirksamen Gewindeprofil.

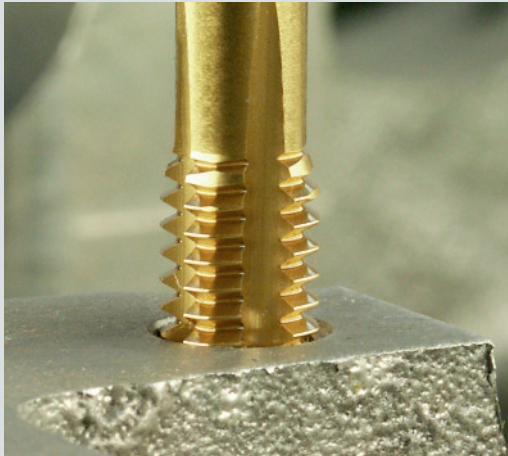

2.13 Cold forming as a production process

The cold forming of threads, according to DIN 8583-5, belongs to the pressure-forming processes. The internal thread is produced by the impression of a helical sequence of thread teeth into the formerly prepared thread hole, the desired profile is formed by pressure. A cold-forming tap is provided with a lead taper and a cylindrical guiding part. The thread helix runs on through both parts. If you look at a cross-section of the tool, there is a polygon shape to be recognised at a right angle to the tool axis. This polygon shape provides forming lobes which carry the effective thread profile.

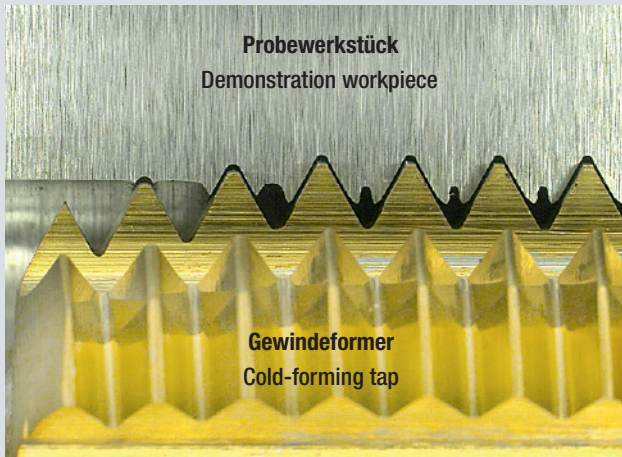

Der Anformbereich ist ausgebildet als Anformkegel, in dem der schraubenförmige Gewindegang im Durchmesser zunimmt. Im Formprozess erzeugt der Anformbereich das Gewinde, wobei die Formkeile nacheinander mit radialer Zustellung in Eingriff kommen und das Gewinde ausformen. Hierbei fließt das Werkstückmaterial von den Gewindespitzen entlang der Gewindeflanken in den Gewindekernbereich. Es entstehen geglättete Flanken sowie im Gewindekernbereich die typische „Kralle“.

Der zylindrische Führungsteil des Gewindeformers glättet die geformte Gewindefläche nach und dient zur axialen Führung des Werkzeugs. Abhängig vom zu bearbeitenden Material sind die wesentlichen Vorteile des Gewindeformens neben sehr guter Oberflächenqualität auch höhere statische und dynamische Festigkeit des Gewindes. Die zu erzeugende Gewindelänge wird nicht durch abzuführende Späne begrenzt, wodurch eine hohe Prozesssicherheit erreicht wird. Die hohe Eigenführung des Werkzeuges verhindert axiales „Verschneiden“. Hervorragende Stabilität des Werkzeuges ist besonders bei kleinen Abmessungen hilfreich.

The lead portion of a cold-forming tap is made as a lead taper, in which the helical thread line is continuously increasing in diameter. In the cold-forming process, the lead taper produces the thread, the forming lobes penetrating the workpiece successively in a radial direction by forming the thread. During this process, the workpiece material “flows” from the thread crests along the thread flanks into the area of the minor thread diameter. This creates smooth flank surfaces and, in the minor diameter area, the typical space pocket. The cylindrical guiding part of the cold-forming tap makes the surface of the produced thread even smoother, and serves to firmly guide the tool axially. Depending on the workpiece material, the essential advantages of cold forming include excellent surface quality but also increased static and dynamic strength of the thread. The length of the thread to be produced is not limited by chips which need to be removed, so process safety is extremely good. The excellent self-guiding characteristics of a cold-forming tap prevent axial “miscutting”. The extraordinary stability of the tools is very helpful, especially with small diameters.

2.14 Der Unterschied zwischen spanend hergestelltem und geformtem Innengewinde

Beim spanend hergestellten Innengewinde werden die zulässigen Belastungswerte durch Zerschneiden der Werkstofffasern beeinträchtigt. Außerdem können Flankenwinkelfehler leichter auftreten, die ungünstige Spannungsverteilungen verursachen und den Traganteil vermindern. Beim geformten Innengewinde ergeben sich nichtunterbrochene Fasern und ein kaltverfestigter Werkstoff. Zusätzliche Flankenwinkelabweichungen, die bei spanend hergestellten Gewinden auftreten können, werden vermieden, weil sich der Werkstoff spielfrei an die Flanke des Werkzeugs verformt. Der unvollständig ausgeformte Kern, ein typisches Merkmal geformter Gewinde, hat keinen Einfluss auf die Ausreißfestigkeit. Durch das Gewindeformen ergeben sich in den Gewindeflanken und insbesondere im Gewindegrund Verfestigungen im Werkstoffgefüge. Diese wirken sich positiv auf die Schwing- und Wechselfestigkeit bei dynamisch beanspruchten Bauteilen aus.

2.14 The difference between a cut thread and a cold-formed thread

With a cut thread, the permissible stress values are limited due to the fact that the grain structure of the material is cut. Also, flank angle errors can occur easily; these will cause a very unfavourable distribution of stress on the thread and limit its holding strength. With a cold-formed thread, the grain of the material is not cut or interrupted, and the material itself shows increased strength, due to its having been compressed by cold-forming. Flank angle errors which are quite common in cut threads are prevented by the material being formed, without any play, along the thread flanks of the tap. The incomplete minor diameter, typical for cold-formed threads, has no influence on the stripping resistance of the thread. Cold forming causes material strengthening on the thread flanks and especially in the root area of the thread. This strengthening of the material structure has a very positive influence on the vibration properties and the general resistance of the thread under dynamic stress.

Spanend hergestelltes Gewinde
Cut thread

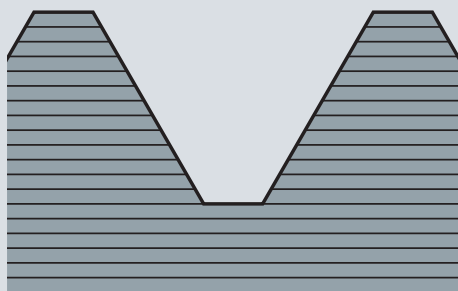
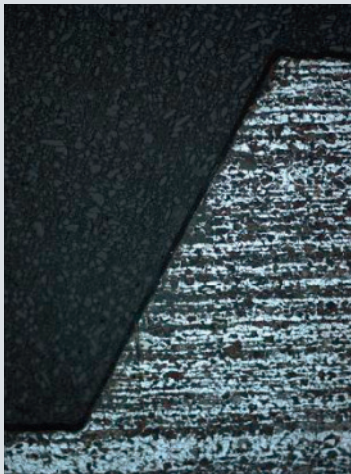

Faserverlauf beim spanend hergestellten Gewinde
Grain structure in a cut thread

Geformtes Gewinde
Cold-formed thread

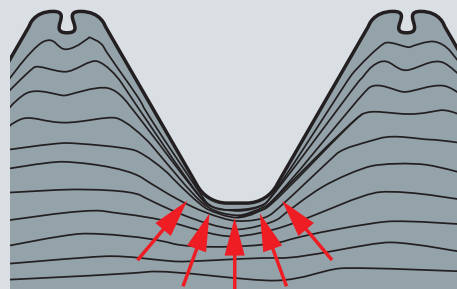
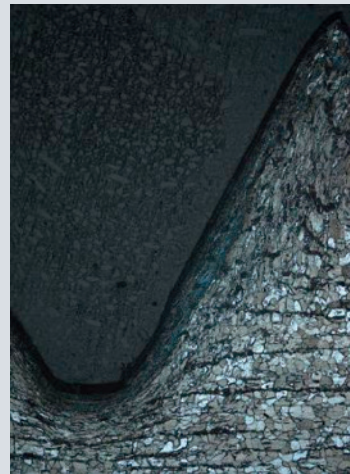

Faserverlauf beim geformten Gewinde, Verfestigung im rissgefährdeten Gewindegrund am Außendurchmesser erhöht die Dauerfestigkeit
Grain structure in a cold-formed thread, strengthening in the root area / on the major diameter which is especially exposed to the danger of crack formation increases resistance

Maximale Gewindetiefe, maximale Gewindesteigung

Über die maximal erreichbare Gewindetiefe und die größtmögliche kaltverformbare Gewindesteigung lässt sich keine generelle Aussage machen. Die erzielbare Gewindetiefe ist größer als beim spanenden Werkzeug. Sie ist in der Praxis hauptsächlich von der Qualität der Kühlschmierung abhängig und durch die Werkzeugbaulänge begrenzt. Die maximal umformbare Gewindesteigung wird von den Werkstück-Werkstoffeigenschaften begrenzt.

Maximum thread depth, maximum thread pitch

The maximum thread depth to be achieved and the fastest possible thread pitch to be produced by cold-forming are a topic about which a general statement is impossible. The possible thread depth is definitely larger than it could be with a cutting tap. In practical work, it depends primarily on the quality of cooling/lubrication, and is limited by the constructional length of the tool.

The maximum thread pitch in cold forming is limited by the workpiece material properties.



- Product Finder
- v_c
- M
- MF
- UNC
- UNF
- G
- SELF-LOCK
- Tech. Info

2.15 Gewidekernloch-Vorfertigungsdurchmesser für Gewindeformer

Einfluss des Vorfertigungsdurchmessers

Bei zu kleinem Vorfertigungsdurchmesser wird das Werkstückmaterial im Gewidekern überformt und es treten sehr hohe Prozesskräfte auf. Ist zu groß vorgefertigt, wird der Gewidekernbereich nicht ausreichend ausgeformt, d.h. der Kerndurchmesser wird zu groß. Um diese negativen Effekte auszuschließen, ist die Toleranz des Vorfertigungsdurchmessers eingeeengt.

In Einsatzfällen mit sehr speziellem Umformverhalten kann es notwendig sein, vom empfohlenen Vorfertigungsdurchmesser abzuweichen und den erforderlichen Vorfertigungsdurchmesser durch Versuche zu ermitteln.

Es ist zu beachten, dass der Vorfertigungsdurchmesser den entstehenden Innengewinde-Kerndurchmesser beeinflusst, wie folgendes Beispiel zeigt. Die Vorfertigung ist sorgfältig herzustellen. Jede Ungenauigkeit und Oberflächenrauheit spiegelt sich im geformten Gewidekerndurchmesser wider.

2.15 Thread hole preparatory diameter for cold-forming taps

The influence of the preparatory diameter

If the preparatory diameter is too small the workpiece material is overformed in the thread root and there are excessive process forces. If the preparatory diameter is too large the thread root is not sufficiently formed, the minor diameter is too small. In order to preclude such negative effects, the tolerance of the preparatory diameter is narrowed down from the start.

In some cases where the forming characteristics are very extraordinary it may be necessary to go without a standard preparatory diameter entirely, and to find the correct diameter by testing.

It is important to know that the preparatory diameter has a decisive influence on the minor diameter of the nut thread, as the following example shows. Every lack of precision, every kind of surface roughness will be mirrored in the finished internal thread and its minor diameter.

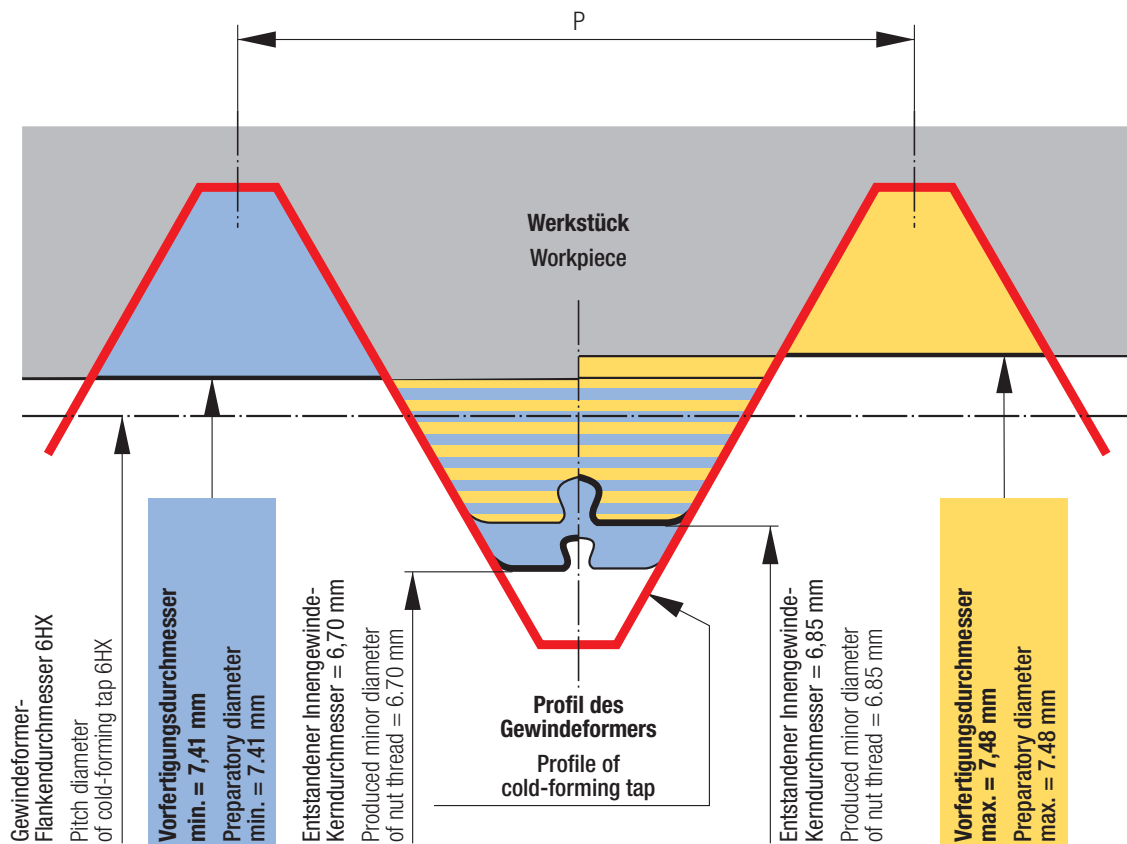

Geformtes Gewide M8-6HX in rost- und säurebeständigem Material, z.B. Werkstoff-Nr. 1.4571, 1.4401, bei unterschiedlichen Vorfertigungsdurchmessern.

Cold-formed thread M8-6HX in corrosion- and acid-proof material, e.g. material no. 1.4571 or 1.4401, with different preparatory diameters.

Mutterhöhe = $2 \times d$
 $v_c = 6,4 \text{ m/min}$
 $n = 255 \text{ min}^{-1}$

Kühlschmierstoff:
 EMUGE-Gewideschneidöl Nr. 5+ HIGH ALLOY

Nut height = $2 \times d$
 $v_c = 6,4 \text{ m/min}$
 $n = 255 \text{ rpm}$

Coolant-lubricant:
 EMUGE thread cutting oil no. 5+ HIGH ALLOY

Während die Einhaltung der Innengewideflankendurchmesser-Toleranz, z.B. 6H Metrisches ISO-Gewide, beim Gewideformen meist keine Schwierigkeiten bereitet, ist beim Innengewidekerndurchmesser – wie oben angedeutet – mit Abweichungen zu rechnen.

In DIN 13-50 sind die vergrößerten Kerndurchmesser-Toleranzen für geformte Innengewide festgelegt. Diese Norm lässt ein Toleranzfeld von 7H für den Innengewidekerndurchmesser zu, bei einer Flankendurchmesser-Toleranz von 6H.

While the observation of the pitch diameter tolerance of the internal thread, e.g. ISO metric thread 6H, offers no problems usually, deviations in the minor diameter of the internal or nut thread must be expected, as demonstrated above.

The extended minor diameter tolerances for cold-formed internal threads are specified in DIN 13-50. This standard allows a 7H tolerance for the minor diameter of the nut thread, with a pitch diameter tolerance of 6H.

2.15 Gewidekernloch-Vorfertigungsdurchmesser für Gewindeformer

2.15 Thread hole preparatory diameter for cold-forming taps

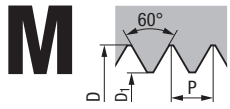

Metrisches ISO-Regelgewinde DIN 13 ISO Metric coarse thread DIN 13

Nenngröße Nom. size		D ₁ (6H)		
D mm	P mm	min. mm	max. mm	empf. rec. mm
M 1	0,25	0,89	0,93	0,9
1,1	0,25	0,99	1,03	1
1,2	0,25	1,09	1,13	1,1
1,4	0,3	1,27	1,31	1,28
1,6	0,35	1,46	1,50	1,47
1,7	0,35	1,56	1,60	1,57
1,8	0,35	1,66	1,70	1,67
2	0,4	1,84	1,88	1,85
2,2	0,45	2,02	2,06	2,03
2,3	0,4	2,14	2,18	2,15
2,5	0,45	2,32	2,36	2,33
2,6	0,45	2,42	2,46	2,43
3	0,5	2,79	2,83	2,8
3,5	0,6	3,24	3,28	3,25
4	0,7	3,69	3,73	3,7
4,5	0,75	4,16	4,23	4,2
5	0,8	4,64	4,68	4,65
5,5	0,9	5,09	5,13	5,1
6	1	5,55	5,63	5,6
7	1	6,55	6,64	6,6
8	1,25	7,41	7,49	7,45
9	1,25	8,41	8,49	8,45
10	1,5	9,28	9,39	9,35
12	1,75	11,16	11,29	11,25
14	2	13,02	13,14	13,1
16	2	15,02	15,14	15,1
18	2,5	16,73	16,89	16,85
20	2,5	18,73	18,90	18,85
22	2,5	20,73	20,90	20,85
24	3	22,47	22,65	22,6
27	3	25,47	25,65	25,6
30	3,5	28,19	28,40	28,35
33	3,5	31,19	31,41	31,35
36	4	33,92	34,16	34,31
39	4	36,92	37,16	37,1
42	4,5	39,64	39,91	39,85
45	4,5	42,64	42,91	42,85
48	5	45,37	45,71	45,65

P ≤ 0,3 mm = Tol. 5H



Metrisches ISO-Feingewinde DIN 13 ISO Metric fine thread DIN 13

Nenngröße Nom. size		D ₁ (6H)		
D mm	P mm	min. mm	max. mm	empf. rec. mm
M 2,5 x 0,35		2,36	2,40	2,37
2,6 x 0,35		2,46	2,50	2,47
3 x 0,35		2,87	2,91	2,88
3,5 x 0,35		3,37	3,41	3,38
4 x 0,5		3,79	3,83	3,8
5 x 0,5		4,79	4,83	4,8
6 x 0,5		5,80	5,83	5,8
6 x 0,75		5,67	5,73	5,7
7 x 0,75		6,67	6,74	6,7
8 x 0,75		7,67	7,74	7,7
8 x 1		7,55	7,64	7,6
9 x 0,75		8,67	8,74	8,7
9 x 1		8,55	8,64	8,6
10 x 0,75		9,67	9,74	9,7
10 x 1		9,55	9,64	9,6
10 x 1,25		9,41	9,49	9,45
11 x 1		10,55	10,64	10,6
12 x 1		11,55	11,64	11,6
12 x 1,25		11,43	11,49	11,45
12 x 1,5		11,29	11,39	11,35
14 x 1		13,55	13,64	13,6
14 x 1,25		13,43	13,49	13,45
14 x 1,5		13,29	13,39	13,35
15 x 1		14,55	14,64	14,6
16 x 1		15,55	15,64	15,6
16 x 1,5		15,29	15,39	15,35
18 x 1		17,55	17,64	17,6
18 x 1,5		17,29	17,39	17,35
18 x 2		17,02	17,14	17,1
20 x 1		19,55	19,65	19,6
20 x 1,5		19,29	19,40	19,35
20 x 2		19,02	19,15	19,1
24 x 2		23,03	23,15	23,1
30 x 2		29,03	29,15	29,1
36 x 3		34,47	34,66	34,6
42 x 4		39,92	40,16	40,1
48 x 3		46,48	46,66	46,6
48 x 4		45,93	46,21	46,15



Whitworth-Rohrgewinde DIN EN ISO 228 Whitworth pipe thread DIN EN ISO 228

Nenngröße Nom. size		D ₁		
D	P Gg/1" (tpi)	min. mm	max. mm	empf. rec. mm
G 1/16 - 28		7,25	7,29	7,25
1/8 - 28		9,25	9,29	9,25
1/4 - 19		12,48	12,59	12,55
3/8 - 19		15,99	16,09	16,05
1/2 - 14		20,02	20,15	20,1
5/8 - 14		21,97	22,10	22,05
3/4 - 14		25,50	25,65	25,6
7/8 - 14		29,26	29,40	29,35
1" - 11		32,05	32,21	32,15

LK-M

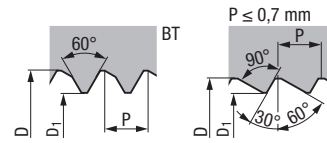

Metr. SELF-LOCK-Regelgewinde, EMUGE-Norm Metric SELF-LOCK coarse thread, EMUGE standard

Nenngröße Nom. size		D ₁		
D mm	P mm	min. mm	max. mm	empf. rec. mm
LK-M 3	0,5	2,82	2,88	2,85
4	0,7	3,77	3,83	3,8
5	0,8	4,77	4,83	4,8
6	1	5,70	5,78	5,7
8	1,25	7,58	7,68	7,6
10	1,5	9,48	9,58	9,5

Die empfohlenen Vorfertigungsdurchmesser ermöglichen einen ausgeformten Kerndurchmesser innerhalb der Toleranz (bei M und MF nach DIN 13-50). Voraussetzung ist stabile Werkzeug- und Werkstückspannung sowie Verwendung von neuwertigen VHM-Spiralbohrern.

Zur Standzeitoptimierung kann auch mit größeren Vorfertigungsdurchmessern gearbeitet werden. Es muss jedoch sichergestellt sein, dass die Kerndurchmesser-Toleranz eingehalten wird (bei M und MF nach DIN 13-50).

Bei schlecht ausformenden Werkstoffen (z.B. GAL) empfehlen wir bei P ≥ 1 mm bzw. 24 Gg/1" um 0,05 mm kleiner vorzubohren.

Die empfohlenen Vorfertigungsdurchmesser sind sorgfältig ermittelt und in der Praxis geprüft. In seltenen Fällen kann es vorkommen, dass die empfohlenen Vorfertigungsdurchmesser nicht zum gewünschten Innengewinde-Kerndurchmesser führen. In diesen Fällen sind die geeigneten Vorfertigungsdurchmesser im Versuch zu ermitteln.

The recommended preparatory diameters enable a cold-formed minor diameter of the thread within tolerance (for M and MF according to DIN 13-50). Preconditions include a stable clamping of tool and workpiece as well as solid carbide twist drills which are new or as good as new.

In order to optimize tool life, larger thread hole preparatory diameters may be used. But it is necessary to ensure that the minor diameter of the thread complies with the tolerance (for M and MF according to DIN 13-50).

We recommend a smaller preparatory diameter by 0.05 mm for difficult to form materials (such as aluminium cast alloys) for P ≥ 1 mm respectively from 24 threads/1".

The recommended preparatory diameters were carefully determined and tested in the field. In rare cases it may happen that the recommended preparatory diameters do not provide the desired minor diameter of the internal thread. In such cases the suitable preparatory diameters must be determined in tests.



Unified-Grobgewinde ASME B1.1 Unified coarse thread ASME B1.1

Nenngröße Nom. size		D ₁ (2B)		
D inch	P Gg/1" (tpi)	min. mm	max. mm	empf. rec. mm
Nr. 4 - 40		2,55	2,58	2,55
Nr. 5 - 40		2,88	2,93	2,9
Nr. 6 - 32		3,12	3,18	3,15
Nr. 8 - 32		3,79	3,83	3,8
Nr. 10 - 24		4,31	4,38	4,35
Nr. 12 - 24		4,97	5,03	5
1/4 - 20		5,72	5,78	5,75
5/16 - 18		7,23	7,34	7,3
3/8 - 16		8,73	8,84	8,8
7/16 - 14		10,20	10,29	10,25
1/2 - 13		11,71	11,84	11,8
9/16 - 12		13,21	13,34	13,3
5/8 - 11		14,70	14,84	14,8
3/4 - 10		17,73	17,89	17,85
7/8 - 9		20,75	20,95	20,9
1" - 8		23,74	23,95	23,9



Unified-Feingewinde ASME B1.1 Unified fine thread ASME B1.1

Nenngröße Nom. size		D ₁ (2B)		
D inch	P Gg/1" (tpi)	min. mm	max. mm	empf. rec. mm
Nr. 2 - 64		2,01	2,05	2,02
Nr. 3 - 56		2,31	2,35	2,32
Nr. 4 - 48		2,60	2,65	2,62
Nr. 5 - 44		2,91	2,95	2,92
Nr. 6 - 40		3,21	3,25	3,22
Nr. 8 - 36		3,83	3,88	3,85
Nr. 10 - 32		4,45	4,48	4,45
Nr. 12 - 28		5,05	5,13	5,1
1/4 - 28		5,92	5,98	5,95
5/16 - 24		7,43	7,49	7,45
3/8 - 24		9,02	9,09	9,05
7/16 - 20		10,49	10,59	10,55
1/2 - 20		12,08	12,19	12,15
9/16 - 18		13,60	13,69	13,65
5/8 - 18		15,19	15,29	15,25
3/4 - 16		18,27	18,40	18,35
7/8 - 14		21,33	21,45	21,4
1" - 12		24,34	24,50	24,45

Product Finder

V_c

M

MF

UNC

UN

G

SELF-LOCK

Tech. Info



- Product Finder
- V_c
- M
- MF
- UNC
- UNF
- G
- SELF-LOCK
- Tech. Info

2.16 Lehrung und Toleranzen geformter Innengewinde

Gewindelehrung – Kombination von Toleranzklassen

Die Gewindelehrung im Flankendurchmesser wird mit üblichen Gewinde-Grenzlehrdornen der zeichnungsmäßig festgelegten Gewindequalifizierung vorgenommen. Es ist zu beachten, dass für geformte Metrische Gewinde die Festlegung der Toleranzen nach DIN 13-50 anzuwenden ist.

Auszug aus DIN 13-50

Grenzabmaße und Toleranzen Limit allowances and tolerances

M Metrisches ISO-Regelgewinde DIN 13 ISO Metric coarse thread DIN 13

Gewinde-Kurzzeichen Thread specification	Flankendurchmesser bei Toleranzfeld 6H Pitch diameter for tolerance 6H		Kerndurchmesser bei Toleranzfeld 7H Minor diameter for tolerance 7H		Toleranz in µm Tolerance in µm
	min.	max.	min.	max.	
M 3	2,675	2,775	2,459	2,639	180
4	3,545	3,663	3,242	3,466	224
5	4,480	4,605	4,134	4,384	250
6	5,350	5,500	4,917	5,217	300
8	7,188	7,348	6,647	6,982	335
10	9,026	9,206	8,376	8,751	375
12	10,863	11,063	10,106	10,531	425
16	14,701	14,913	13,835	14,310	475

2.16 Gauging and tolerances of cold-formed threads

Thread gauging – Combination of tolerance classes

Thread gauging in the pitch diameter is done with the usual go/no-go thread plug gauges as specified in the well-known thread standards. It should be noted that for cold-formed Metric threads the specifications for tolerances according DIN 13-50 apply.

Extract from DIN 13-50

Grenzabmaße und Toleranzen Limit allowances and tolerances

MF Metrisches ISO-Feingewinde DIN 13 ISO Metric fine thread DIN 13

Gewinde-Kurzzeichen Thread specification	Flankendurchmesser bei Toleranzfeld 6H Pitch diameter for tolerance 6H		Kerndurchmesser bei Toleranzfeld 7H Minor diameter for tolerance 7H		Toleranz in µm Tolerance in µm
	min.	max.	min.	max.	
M 8 x 1	7,350	7,500	6,917	7,217	300
10 x 1	9,350	9,500	8,917	9,217	300
12 x 1,5	11,026	11,216	10,376	10,751	375
14 x 1,5	13,026	13,216	12,376	12,751	375
16 x 1,5	15,026	15,216	14,376	14,751	375

1. Anwendungsbereich

Diese Norm legt Gewindetoleranzen für durch Gewindeformen (siehe DIN 8583-5) herzustellende Innengewinde fest. Das Fertigungsverfahren Gewindeformen ist vorzugsweise für Regelgewinde M3 bis M16 und Feingewinde M8 x 1 bis M30 x 2 nach DIN ISO 262 und DIN ISO 965-2 anwendbar.

2. Toleranzen

Für durch Gewindeformen herzustellende Innengewinde der Einschraubgruppe N nach DIN ISO 965-1 werden nach DIN 13-50 folgende Toleranzfelder festgelegt:

- für Flankendurchmesser 6H (wie DIN ISO 965-1)
- für Kerndurchmesser 7H (DIN 13-50)

Hinweis: Bei Gewindetoleranzen, die nicht in DIN 13-50 genormt sind, ist sinnvollerweise analog zu verfahren, d.h., die Kerndurchmesser-Toleranz sollte gegenüber der Flankendurchmesser-Toleranz erhöht werden – in der Regel um eine Qualitätsstufe. In solchen Fällen ist allerdings durch den Werkzeuganwender zu klären, ob die erhöhte Toleranz im bearbeiteten Werkstück zulässig ist.

3. Toleranzen des Gewindeteils

Der Gewindeteil des Formers wird im Vergleich zum Gewindebohrer mit einer erhöhten Toleranzlage ausgeführt, da der Werkstoff nach der plastischen Verformung um den elastischen Anteil zurückfedert. Das erzeugte Gewinde ist deshalb kleiner als der Formteil des Formers. Der Former lässt sich nach dem Gewindeformen nicht nochmals von Hand in das Gewinde einschrauben, was beim Gewindebohren meist problemlos realisierbar ist. Darum ist es nötig, den Gewindeteil näher an die obere Toleranzgrenze des Innengewindes zu legen.

1. Application range

This standard specifies thread tolerances for internal threads to be produced by cold forming (see DIN 8583-5). The production process cold forming is to be used, preferably, for coarse threads M3 to M16 and for fine threads M8 x 1 to M30 x 2 according DIN ISO 262 and DIN ISO 965-2.

2. Tolerances

For internal threads of screw-in class N according DIN ISO 965-1, which are to be produced by cold forming, the following tolerance zones have been specified according to DIN ISO 13-50:

- for the pitch diameter 6H (as in DIN ISO 965-1)
- for the minor diameter 7H (DIN 13-50)

Note: For thread tolerances which are not specified in DIN 13-50, it is usually recommended to proceed in an analogue way, i.e. to raise the minor diameter tolerance in relation to the pitch diameter tolerance – normally by one tolerance step. However, in such cases the user has to check first if the raised tolerance is acceptable in the workpiece to be produced.

3. Tolerance of the thread part

The thread part of a cold-forming tap is generally produced with an increased tolerance since the workpiece material will always contract after the plastic forming process, depending on its elasticity. Consequently, the produced thread is always smaller than the thread part of the cold-forming tap. You will never be able to screw the cold-forming tap back into the thread manually after the cold-forming process, as would be possible without any problem with a cut thread and a cutting tap. For this reason, it is necessary to manufacture the thread part of a cold-forming tap closer to the upper tolerance limit of the internal thread.

2.17 Technischer Fragebogen: Gewindeformen

Firma:
 Ansprechpartner:
 Telefon:
 Fax:
 E-Mail:

Abmessung:
 Ausführung:
 Artikel-Nr.:
 Projekt:

Werkstückbezeichnung:

Kernlochdurchmesser:

- gebohrt geräumt gestanzt
 gegossen gezogen

Kernlochform (bitte Maße eintragen):

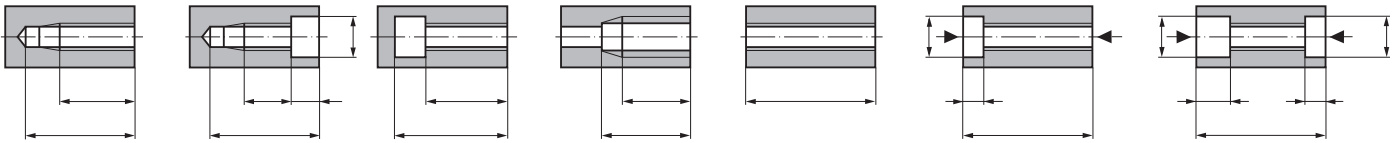

Maschine:

Hersteller:
 Typ:
 Antriebsleistung: kW

- horizontal Werkzeug rotierend
 vertikal Werkzeug stehend

Schnittdaten:

Drehzahl n: min⁻¹
 Umfangsgeschwindigkeit v_c: m/min

Vorschub:

- Andruckkurve Sonstige:
 Hydraulik
 Leitpatrone
 NC-gesteuert
 Synchronspindel
 Zahnräder

Werkzeugaufnahme:

- starr (Spannzange)
 Gewindefresser } Hersteller:
 Gewindefresser } Typ:
 mit Überlastkupplung
 mit Längenausgleich
 mit achsparalleler Pendelung
 mit innerer Kühlschmierstoff-Zufuhr Druck: bar

Spindelaufnahme:

MK / SK / HSK / TR / andere:
 DIN / ANSI / JIS / andere:

Werkstückwerkstoff:

Bezeichnung:
 Behandlungszustand:
 Festigkeit: N/mm²
 Härte: Dehnung: %
 kurzspanend langspanend

Kühlung:

- Öl Emulsion % Trocken
 Umlauf Pinsel Nebel Sonstige:

Werkzeug-Empfehlung:

Ausführung:
 Artikel-Nr.:
 Schaftdurchmesser: DIN:
 Besonderheit:
 Bisher verwendete Werkzeuge (Hersteller):
 Standwert: (Anzahl der Gewinde)

Aufgenommen von:

Datum / Unterschrift:

- Product Finder
- V_c
- M
- MF
- UNC
- UNF
- G
- SELF-LOCK
- Tech. Info

2.17 Technical questionnaire: Cold forming of threads

Company:
Contact:
Phone:
Fax:
E-mail:

Size:
Design:
Article no.:
Project:

Workpiece description:

Thread hole diameter:

- drilled
- broached
- stamped
- cast
- drawn

Hole type (please enter dimensional specifications):

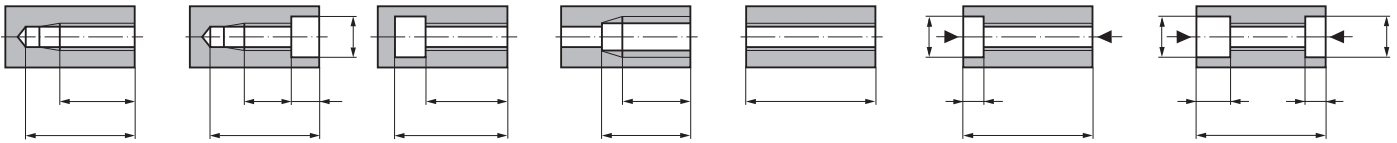

Machine:

Manufacturer:
Type:
Power: kW

- horizontal
- vertical
- rotating tool
- standing tool

Cutting data:

Speed n: rpm
Circumferential speed v_c: m/min

Feed:

- Pressure cam
- Hydraulics
- Lead screw
- NC-controlled
- Synchronous spindle
- Gear wheels
- Others:

Tool holder:

- rigid (collet)
 - Tapping attachment
 - Tap holder
 - with overload clutch
 - with length compensation
 - with axial parallel floating
 - with internal coolant supply
- Pressure: bar

Manufacturer:
Type:

Spindle adaptation:

MT / ISO taper / HSK / TR / others:
DIN / ANSI / JIS / others:

Workpiece material:

Description:
Condition during work:
Tensile strength: N/mm²
Hardness:
Elongation: %

- short-chipping
- long-chipping

Cooling/lubrication:

- Oil
- Emulsion %
- Dry
- Circulation
- Brush
- Mist
- Others:

Tool recommendation:

Design:
Article no.:
Shank diameter: DIN:
Special features:
Tools used until now (manufacturer):
Tool life: (no. of threads)

Filled in by:

Date / signature: